

STUDER

A 62



Studio Tape Recorder

STUDER A-62

The Tape Recorder STUDER A 62 exhibits the following design features :

- Fully up to date transistorised plug-in electronics
- New tape transport mechanism with electronic tape tension control
- Plug-in equalisers
- Interchangeable head-blocks
- Light weight and small dimensions
- Simple to operate, all functions can be remote controlled
- Mounting position: anything from horizontal to vertical

The interchangeable sub-assemblies allow this machine to be quickly adapted to all the requirements of modern mono and stereo recording.

Its small dimensions and the light weight make the STUDER A 62 eminently suitable for mobile use and in confined spaces.

Great care in manufacture and in testing ensure a high standard of quality in every STUDER A 62.

Please read these operating instructions carefully.

BEFORE SWITCHING THE MACHINE ON

it is necessary to be familiar with the overall design concept of the STUDER A 62 in order to maintain the excellent electrical and mechanical properties over a long period of time.

Contents

A. GENERAL

1. TECHNICAL DETAILS
2. DIMENSIONS
3. BEFORE THE INITIAL OPERATIONS
4. BRIEF INSTRUCTIONS FOR INITIAL OPERATIONS

B. OPERATION

1. EARTHING
2. CONNECTIONS
3. SWITCHING ON, SPEED SELECTOR
4. FUNCTION OF THE PUSH BUTTONS
5. TAPE PATH
6. RECORDING
7. PLAYBACK
8. EDITING
9. TIMING INDICATOR
10. REMOTE CONTROL

C. DISMANTLING

1. MECHANICAL CONSTRUCTION
2. DISMANTLING PROCEDURE

- C.2.1. REMOVING OF THE HEADS
- C.2.2. REMOVING OF AMPLIFIER FRAME
- C.2.3. REMOVING OF CAPSTAN MOTOR
- C.2.4. REMOVING OF CAPSTAN DECK
- C.2.5. REMOVING OF SPOOLING DECK

3. DECK PLATE

D. SPOOLING DECK

1. SPOOLING MOTORS
2. STOP BRAKES / EDITING BRAKES
3. OPERATIONAL BRAKES
(TAPE BACK-TENSION)
4. MAINS SECTION

- D.2.1. BRAKING TORQUE ADJUSTMENT
- D.2.2. REMOVING OF THE BRAKE DRUMS

- D.3.1. TAPE TENSION, BRAKING (FAST WIND)
- D.3.2. TAPE TENSION CONTROL

E. TAPE DECK

1. HEAD BLOCK
2. TAPE GUIDES
3. END-OF-TAPE SWITCH
4. PUSH BUTTON UNIT
5. CAPSTAN MOTOR ASSY
6. PINCH WHEEL MECHANISM
7. TIMING INDICATOR

- E.1.1. HEAD MOUNTINGS

- E.3.1. END OF TAPE SWITCH - SPOOL ADJUSTMENT

- E.6.1. MOUNTING POSITION

F. AMPLIFIER FRAME

1. RECORD AMPLIFIER
2. PLAYBACK AMPLIFIER
3. STABILISER
4. TAPE TENSION CONTROL

- F.1.1. OSCILLATOR

G. ALIGNMENT PROCEDURE

1. TAPE TENSION CONTROL
2. TAPE START
3. ELECTRICAL ADJUSTMENTS AND MEASUREMENTS
4. PLAYBACK CHANNEL
5. RECORD CHANNEL
6. DISTORTION MEASUREMENTS
7. NOISE MEASUREMENTS
8. ERASE MEASUREMENTS
9. WOW-AND-FLUTTER AND TAPE SLIP MEASUREMENTS
10. TWO CHANNEL AND STEREO MACHINES / ADDITIONAL MEASUREMENTS

- G.2.1. TENSIONING ARMS (JOCKEY ARMS)
- G.2.2. PINCH-WHEEL MECHANISM DAMPING
- G.2.3. STARTING TIME

- G.3.1. GENERAL
- G.3.2. TEST INSTRUMENTS

- G.4.1. LEVEL ADJUSTMENT
- G.4.2. PLAYBACK HEAD-AZIMUTH ALIGNMENT
- G.4.3. PLAYBACK FREQUENCY RESPONSE

- G.5.1. RECORD HEAD - AZIMUTH ALIGNMENT
- G.5.2. BIAS ADJUSTMENT
- G.5.3. LEVEL ADJUSTMENT
- G.5.4. FREQUENCY RESPONSE VIA TAPE

- G.9.1. SLIP MEASUREMENT

- G.10.1. CROSS-TALK
- G.10.2. PHASE ANGLE MEASUREMENT
- G.10.3. PHASE ERROR VIA TAPE

H. SERVICING RECOMMENDATIONS

I. SPARE PARTS LIST

K. CIRCUIT DIAGRAMS

A

B

C

D

E

F

G

H

I

K

A.1. Technical Details

Dimensions :	see fig. 1
Weight :	Chassis : Mono 55 Ibs Stereo 57 Ibs Carrying case additional 21 Ibs
Current consumption:	110, 117, 125, 150, 220 and 250 Volts 50 c/s app. 100 Watts
Power consumption :	Record stereo 7 1/2 i.p.s. : 110 W at 220 V Fast wind : 120 W at 220 V
Speed accuracy:	$\pm .2\%$ of nominal
Tape slip:	max. .1% deviation for tape spooling - diameters between 60 mm and 250 mm. (between 2 1/2" and 10")
Wow-and-flutter in accordance with DIN 45507:	$\pm .05\%$ at 15" $\pm .1\%$ at 7 1/2"
Tape tension control:	fully electronic, without mechanical sensing element
Starting time:	max. 1.5 seconds
Rewind time:	max. 120 seconds for 2,400 ft of LGR tape
End of tape switch:	electro-dynamic, without lever
Tape spools :	cine, (NAB and DIN adapters) maximum diameter 10 1/2"
Timing indicator:	60 minutes, 60 seconds, accuracy .2%.(7,5")
Amplifiers :	equipped with professional transistors
Input :	minimum 200 mV, balanced, with pre-set gain control

Output :	7 - 4.4 V into 200 ohms, with pre-set gain control, balanced
Equalisation :	Interchangeable plug-in equalisers : CCIR, NAB or special equalisations
Frequency response via tape (DIN equalisation) :	15 i.p.s. 30 c/s - 15 kc/s +1 -2 db 7½ i.p.s. 40 c/s - 15 kc/s +1 -2 db
Distortion via tape :	Max. 2% at 1 kc/s, measured with LGR tape at 200 mM
Weighted signal-to-noise ratio (without tape) :	at 15 i.p.s. better than 70 db at 7½ i.p.s. better than 68 db
Signal-to-noise ratio via tape :	at 15 i.p.s. better than 58 db at 7½ i.p.s. better than 56 db
Weighted signal-to-noise ratio via tape :	at 15 i.p.s. better than 59 db at 7½ i.p.s. better than 58 db in the case of stereo these values are reduced by about 4 db due to the reduced track width
Cross-talk in stereo operation :	at 1 kc/s : > 40 db 55 db in half-track operation
Phase angle error in stereo operation at 10 kc/s :	less than 10°
Oscillator frequency :	80 kc/s
Stray field :	max. 50 mG at 2" from the machine
Mechanical running noise :	better than 40 Phon (in replay)
Transistors :	51 transistors, 51 diodes (stereo)
Mounting position :	horizontal or vertical (see E. 6.1.)

A.2. Dimensions

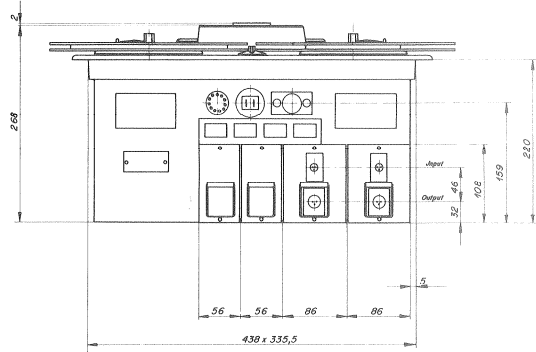
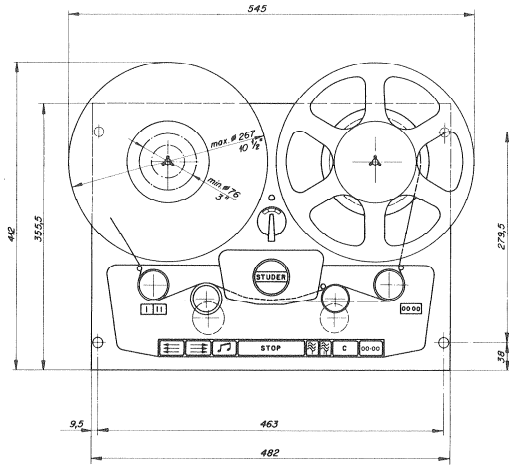

Fig 1

A-62 AS CHASSIS UNIT

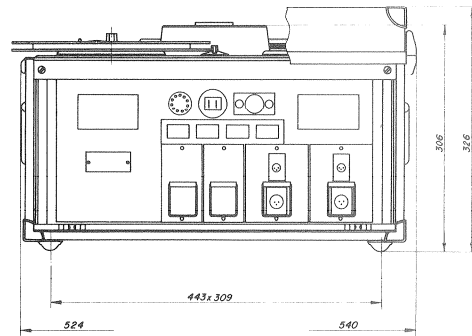
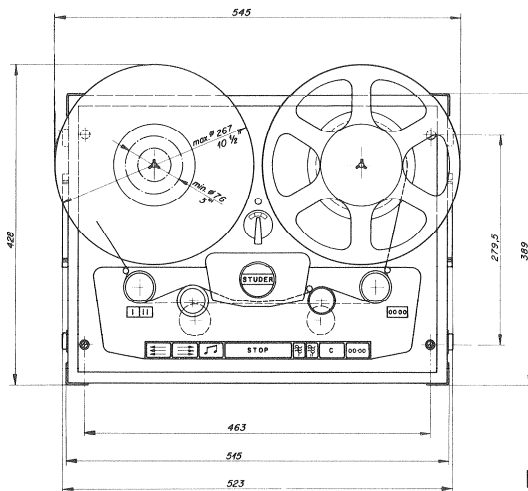

Fig 2

A-62 IN PORTABLE CASE

STUDER**A - 62**

A.3 BEFORE THE INITIAL OPERATION

CHECK THAT ALL RELAYS, EQUALISER UNITS, THE MOTOR RELAY AND THE FUSES ARE FIRMLY IN POSITION. IT SHOULD BE ASCERTAINED FURTHERMORE THAT THE AMPLIFIER, STABILISER AND TAPE TENSION CONTROL PLUG-IN UNITS ARE LOCKED IN POSITION.

MAKE SURE THAT THE MAINS VOLTAGE AND FREQUENCY CORRESPOND WITH THE MARKINGS ON THE NUMBER PLATE. THE VOLTAGE CAN BE SET BY LIFTING THE VOLTAGE SELECTOR AND TURNING IT TO THE APPROPRIATE MAINS VOLTAGE.

A.4 BRIEF INSTRUCTIONS FOR INITIAL OPERATION

SWITCHING ON

Turn the rotary switch behind the head-block to the appropriate position according to the desired tape speed.

LOADING THE TAPE



The tape path is shown in fig. 4. Special care should be taken that the tape runs correctly over the two tensioning arms.

FAST FORWARD

The key  is the fast forward key.

FAST REWIND

The fast rewind key is marked . Both functions are self-holding. It is perfectly permissible to change directly from fast forward to fast rewind.

STOP	The STOP key serves to stop the machine from any mode of operation.
PLAYBACK	The playback key  starts the machine in the replay mode. It is permissible to switch from playback directly into fast wind. On the other hand the playback key is blocked as long as the tape is in motion. The tape must be stationary before the machine can be switched to playback.
END OF TAPE SWITCH	The left-hand guide roller serves to trigger the end of tape switch. The end of tape switch will stop the machine from all modes of operation as soon as the left hand guide roller has come to rest. To prevent the machine from being switched from fast wind directly into playback the playback button is interlocked via the end of tape switch.
RECORD	The record buttons  only work in conjunction with the playback button. Both keys have to be depressed simultaneously even if the machine is already running in playback. By means of this interlock mechanism, accidental erasure is made almost impossible.
EDITING	By means of the button  the fly-wheel idler and the rubber pressure roller are brought into such a position that the tape comes into contact with the heads without being gripped by the capstan. At the same time, one of the two brake systems is released so that the tape can be moved easily by hand in both directions. The tape can also be moved forward or backwards by means of the fast wind buttons. In order to prevent excessive head wear by rewinding whole tapes in the editing position the fast wind buttons are no longer self-holding i.e. the spooling motors will only pull as long as the buttons are held down. The playback and record modes can be obtained directly from the editing position without going through "STOP".

This provides a rapid start by saving switching time.

TIMING INDICATOR

At $7\frac{1}{2}$ i.p.s. the counter reads directly in minutes and seconds. The counter can be re-set at any time by means of the key marked 00.00.

REMOTE CONTROL

The operating functions can be remote controlled (fig. 5). The editing position and the separate track selection in the case of two-track machines cannot be obtained via remote control. If the machine is remote started by means of a fader contact all the buttons are automatically cancelled to prevent operational errors.

IF THE MACHINE IS NOT REMOTE CONTROLLED
THE DUMMY PLUG MUST BE PLUGGED INTO THE
REMOTE CONTROL SOCKET.

THE MAINS SWITCH SHOULD NOT BE TURNED TO THE "OFF" POSITION EXCEPT WHEN
THE TAPE IS STATIONARY I.E. IN "STOP" POSITION.

B. Operation

B
1
2

B.1 EARTHING

The chassis is permanently connected to mains earth (in accordance with regulations). The earthy side of the circuit is connected to chassis at the factory. If the amplifiers are to be earthed separately, the link which is shown in fig. 3 with an arrow should be removed and replaced with a .1 μ F condenser.

The amplifiers will then be earthed via the pins No.1 on the CANNON in-and output connectors .

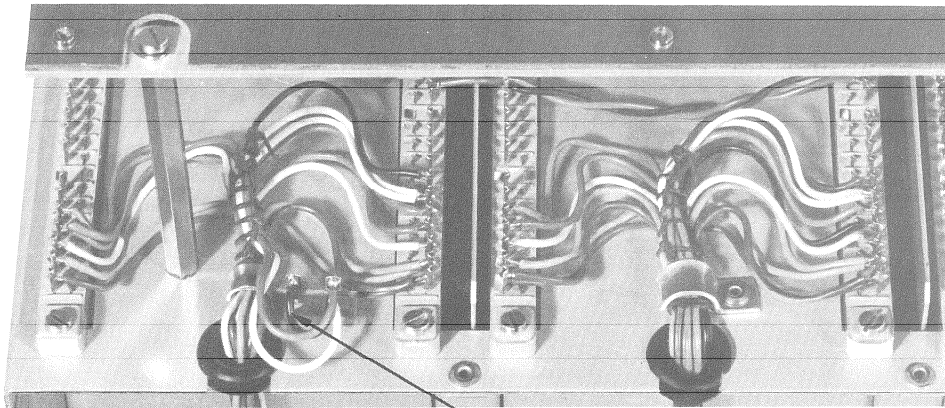

BLUE: EARTHY SIDE OF AMPLIFIERS
WHITE: EARTHY SIDE OF TAPE DECK CIRCUIT (+24V OF RELAY SUPPLY)

Fig 3

B.2 CONNECTIONS

The audio frequency inputs and outputs are made by means of the CANNON connectors XLR - 3 - 31 and XLR - 3 - 12 C which are supplied with the machine.

Pin 1 goes to the earthy side of the circuit, pins 2 and 3 are the balanced audio connections .

We recommend the use of the appropriate EMT cables for all signal and power supply connections because of their excellent screening characteristics .

B. 3 SWITCHING AND SPEED SELECTION

The rotary switch behind the head-block serves to select the required speed and acts as on-off switch.

7 1/2 i.p.s. ----- 15 i.p.s.

A red pilot light shows that the machine is switched on.

B. 4 FUNCTION OF THE CONTROL BUTTONS

The function of the control buttons is shown in fig. 4.

For mono full track operation, the record button I should be pressed and the amplifier unit should be plugged into the channel I position.

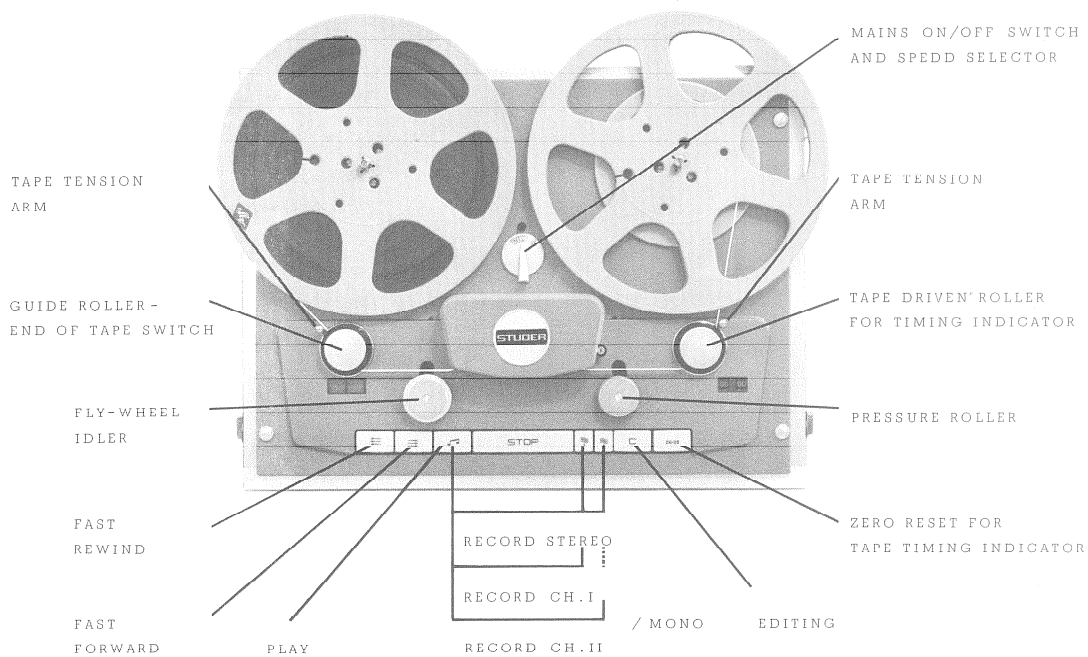

Fig. 4

B. 5 LOADING THE TAPE

The tape path is shown in Fig. 4

CARE SHOULD BE TAKEN THAT THE TAPE IS CORRECTLY LACED AROUND BOTH TAPE TENSION ARMS.

USE HUB DIAMETER OF 4 INCH. ON THE TAKE-UP SIDE.

B. 6 RECORDING

The machine is switched into "record" by simultaneously depressing the playback button (marked with the notes) and the record button (with the HF symbol). The fact that both keys have to be depressed simultaneously acts as safeguard against accidental erasure.

If it is desired to go from "playback" directly into "record" the playback button must be depressed together with the record button.

For full-track mono recording the record button I should be used (with the appropriate head-block and the amplifier unit plugged in channel I). For stereo recording the record buttons I and II must be pressed. For half-track mono the button I or II is pressed as required.

Red indicator lamps in front of the left-hand tape guide roller indicate the mode of operation.

B. 7 PLAYBACK

Once the machine is switched on the machine can be switched to replay by pressing the "playback" button. The "playback" button is blocked during fast wind and will not function until the "stop" button has been pressed and the tape has come to a halt. This makes it impossible to throw loops or to break the tape.

It is, of course, possible to go straight from "playback" into "fast wind".

B. 8 EDITING

The new design of the tape transport mechanism enables the tape to be laced in a straight line. This has been achieved by means of a pivoted fly-wheel idler and pressure roller. The button marked "C" will move these rollers to the editing position. The tape comes thereby into contact with the heads, but is not gripped by the capstan.

Furthermore, each spooling motor is equipped with 2 braking systems which normally operate simultaneously. In the "Editing" position only the lower brake system is in operation so that the spools can be easily rotated by hand. This second braking system prevents the spools from running on freely and spilling the tape.

Furthermore, the holding circuit for the "fast wind" buttons is cancelled in the "Editing" position. The appropriate spooling motors are therefore only energised as long as the button is depressed. It is therefore not necessary to go via the "stop" position. It is possible to go from "Editing" directly into record or replay. This provides a quick start as the pressure roller is already closer to the capstan than in the "stop" position.

B. 9 TIMING INDICATOR

The timing indicator is calibrated in minutes and seconds. The high accuracy of this clock is maintained during "fast wind". The even numbers are marked directly (from 00 to 58 minutes or seconds). The odd numbers in between are marked for the minutes and in the case of the seconds they can be estimated quite accurately.

7½ i.p.s.	=	time indicated directly
15 i.p.s.	=	indicated time divided by 2

The timing indicator can be reset to zero at any time by means of the button marked 00-00. This button should be fully depressed. The zero reset is mechanical.

B. 10 REMOTE CONTROL

The machine may be remote controlled by means of five push-buttons. The connections are made by means of an 11-pole AMPHENOL plug 86-CP 11 which is plugged into the AMPHENOL "Remote Control" socket on the machine.

IF THE MACHINE IS NOT REMOTE CONTROLLED THE DUMMY PLUG (BRIDGING PIN 3 AND 4) MUST BE FITTED

The machine can be switched to "playback" by means of a switch contact in the fader in the mixer. With the fader turned down the contact is open. It should be connected to pin 11. When the fader is turned up the contact is made and the relay RF energised. All the control buttons on the machine are thereby put out of action as in remote control and the tape can only be stopped by turning down the fader. This is a useful safeguard against accidental interference.

The circuit of the remote control system is as follows :

(The figures refer to the pin numbers)

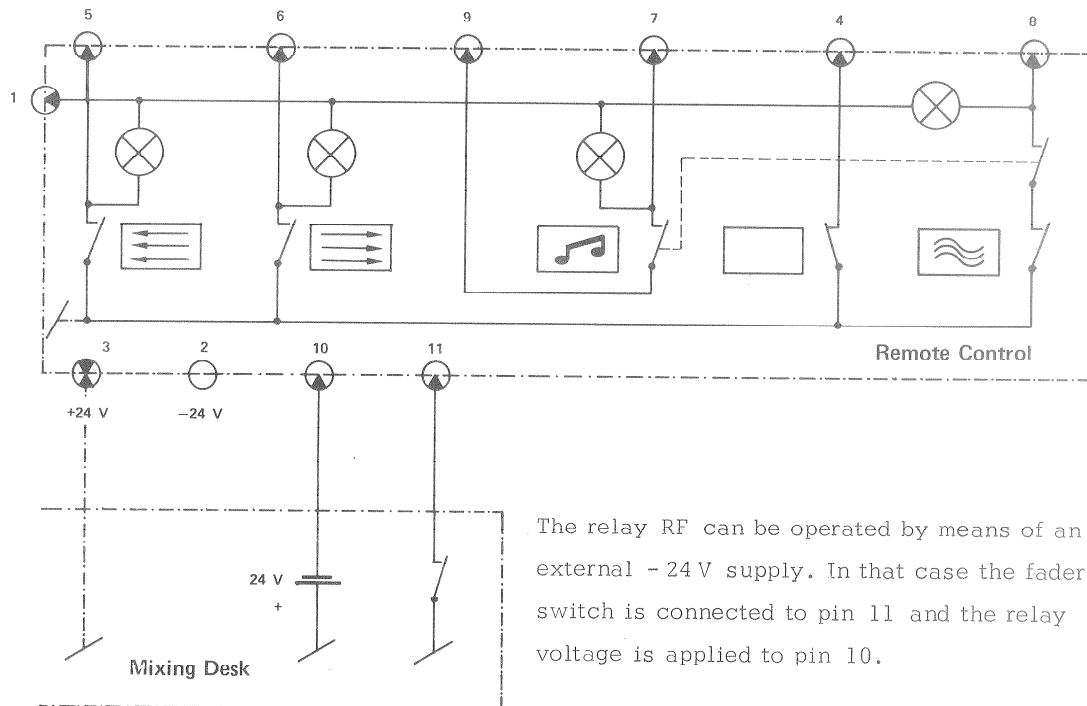

The relay RF can be operated by means of an external -24 V supply. In that case the fader switch is connected to pin 11 and the relay voltage is applied to pin 10.

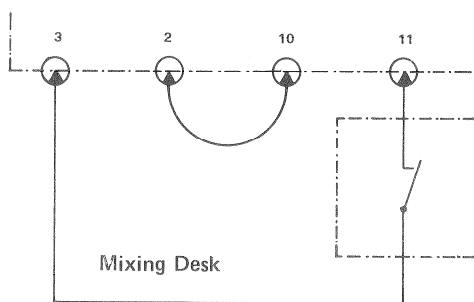

If the supply voltage for the relay is to be obtained from the machine itself (e.g. on location) the fader contact should be connected between pin 11 and 3. At the same time, the internal relay supply voltage (-24V) should be linked from pin 2 to pin 10.

Fig 5

Return confirmation of recording can only be achieved if the separate track selection is dispensed with e.g. full track or stereo operation.

For this purpose the push-button printed circuit card should be modified (circuit diagram ①, tape transport unit 7.062.101 - 104). The diodes D 12 and D 13 should be shorted out. With this modification the remote control unit for the STUDER C 37 may also be used.

Pilot lamps = 24 V

C. Dismantling

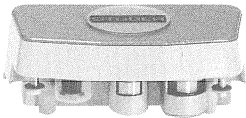

Headblock

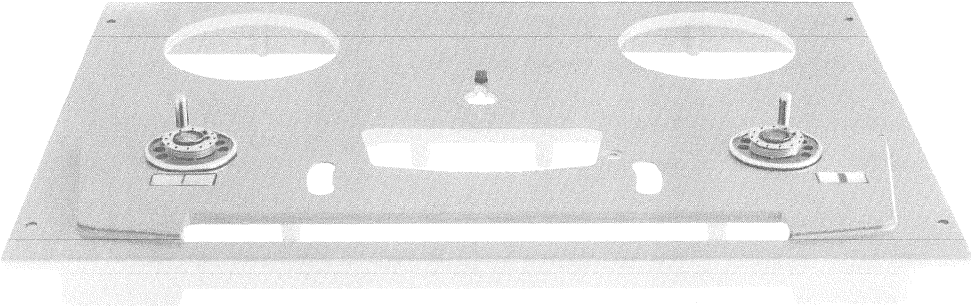

Deckplate

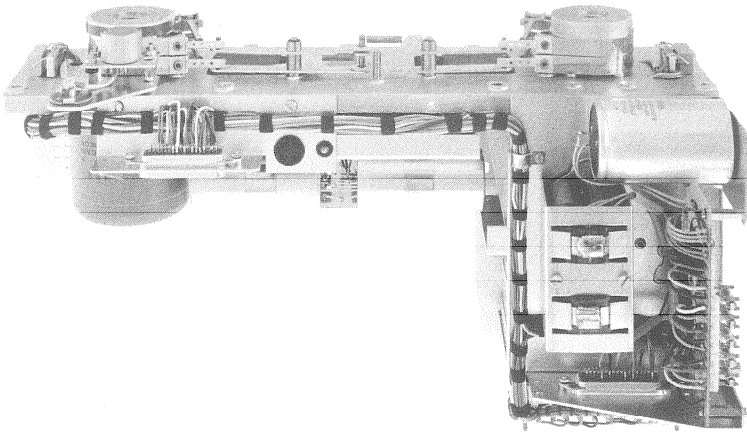

Spooling Deck

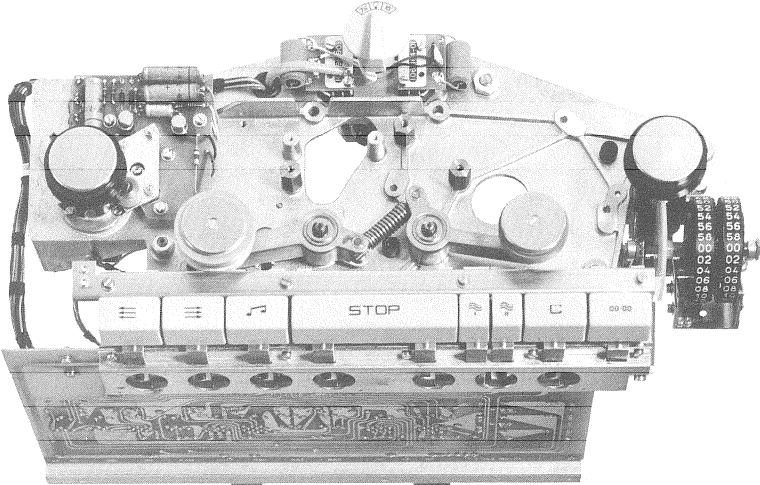

Capstan Deck

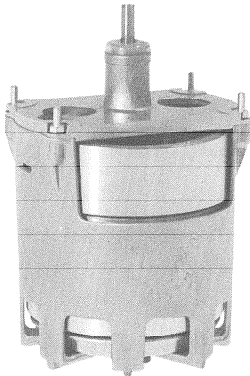

Capstan Assy.



C. 1 MECHANICAL CONSTRUCTION

The entire tape transport mechanism is held together by the cast aluminium deck plate. The spooling deck and the capstan deck are screwed onto it.

The spooling deck contains the spooling motors and brakes and the entire mains section and the magnetic amplifier for the tape tension control.

The capstan deck contains the capstan motor, pressure roller and the tape guides. The control buttons for the tape transport, the headblock and the timing indicator are also part of this sub-assembly.

The amplifier frame houses the plug-in amplifiers, the stabiliser and the tape tension control amplifier.

C. 2 DISMANTLING PROCEDURE

REMOVAL FROM CASE

REMOVAL OF AMPLIFIER FRAME

REMOVAL OF CAPSTAN MOTOR

REMOVAL OF CAPSTAN DECK

REMOVAL OF SPOOLING DECK

C. 2.1 REMOVAL FROM CASE

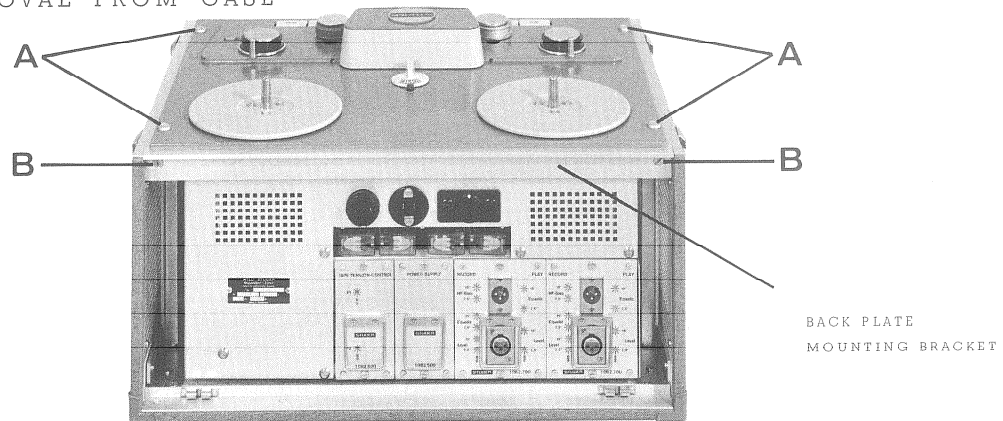

Fig. 6

The chassis of the A-62 can be withdrawn backwards from the case by removing the screws A on the front plate and the screws B, as well as the back plate mounting bracket. The chassis can be laid conveniently on its side with the mains section facing downwards.

C
1
2

C.2.2 REMOVAL OF AMPLIFIER FRAME

The procedure for removing the amplifier frame is as follows :

1. Remove headblock and unscrew the AMPHENOL connector.
2. Withdraw the plug-in amplifier unit K 1 from the frame.
3. Remove the plug attached to the harness (Amphenol)
4. Unscrew the Rear plate (4 screws)
Motor frame (4 screws)
Push Button board (2 screws)
5. Withdraw the Cinch plug for the tape tension control.
6. Lift the amplifier frame off carefully and withdraw the AMPHENOL contact strip carefully through the spooling deck.

C
2

C.2.3. REMOVAL OF CAPSTAN MOTOR ASSY. (fig.7)

WHEN REMOVING THE CAPSTAN MOTOR ASSY. GREAT CARE SHOULD BE TAKEN TO AVOID DAMAGING THE PRECISION GROUND CAPSTAN. (FOR THIS REASON IT IS ADVISABLE TO REMOVE THE CAPSTAN MOTOR ASSY. BEFORE REMOVING THE CAPSTAN DECK.)

1. Unplug the cable to the capstan motor. (Plugged in by the speed change switch.)
2. Loosen the two allen screws (A) (No. 5 key), push the fixing elements aside and then carefully withdraw the motor downwards.
3. When re-assembling, make sure that the connecting cable is on the correct side and that the four locating pins on the capstan housing are properly located in the deck plate.

Removal of the Capstan Motor Assembly without removing the amplifier frame follow instructions C.2.3.1. and C.2.3.2. in reversed sequence.

If the motor is replaced the humbucking has to be re-adjusted (with the little Mu-metal plate on the motor housing).

To adjust for minimum hum the machine should be in play mode (15 i.p.s.)

The Mu-metal plate should be adjusted for and secured in the position which gives minimum hum.

C.2.4 REMOVAL OF CAPSTAN DECK

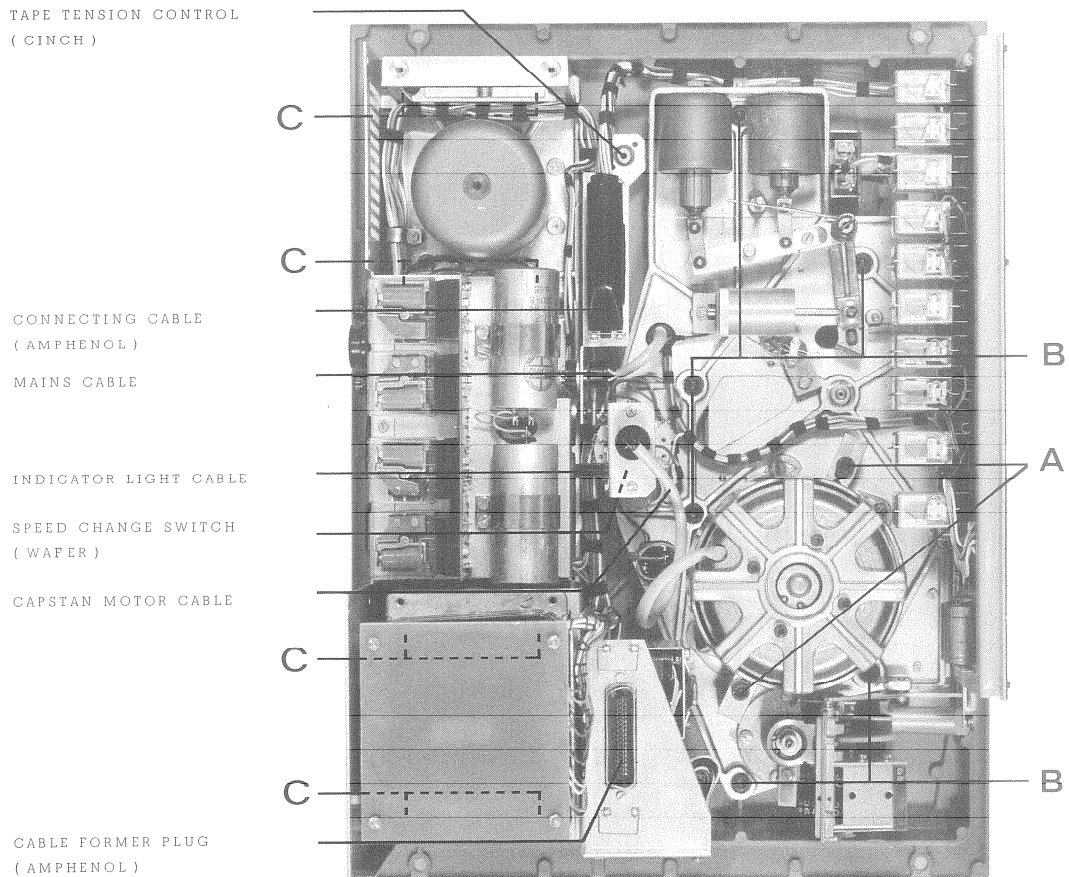

Fig 7

1. Withdraw the speed change switch upwards from the deckplate. Remove the cover plates from the guide rollers and unscrew the rollers. Unscrew fly-wheel pulley and pressure roller.
2. Remove the amplifier frame as described in section C.2.2.
3. Remove the capstan motor as described in section C.2.3.
4. Remove the cable former (AMPHENOL plug), mains cable and indicator lamp cable.
5. Undo the six allen screws (B) and carefully withdraw capstan deck.

C.2.5 REMOVAL OF SPOOLING DECK

1. Unscrew the spooling plates on the deckplate.
2. Remove the amplifier frame as described in section C.2.2.
3. Unplug connecting cable (AMPHENOL plug) and mains cable.
4. Of the eight allen screws C (fig. 7) unscrew the two which are marked in fig. 8 completely.

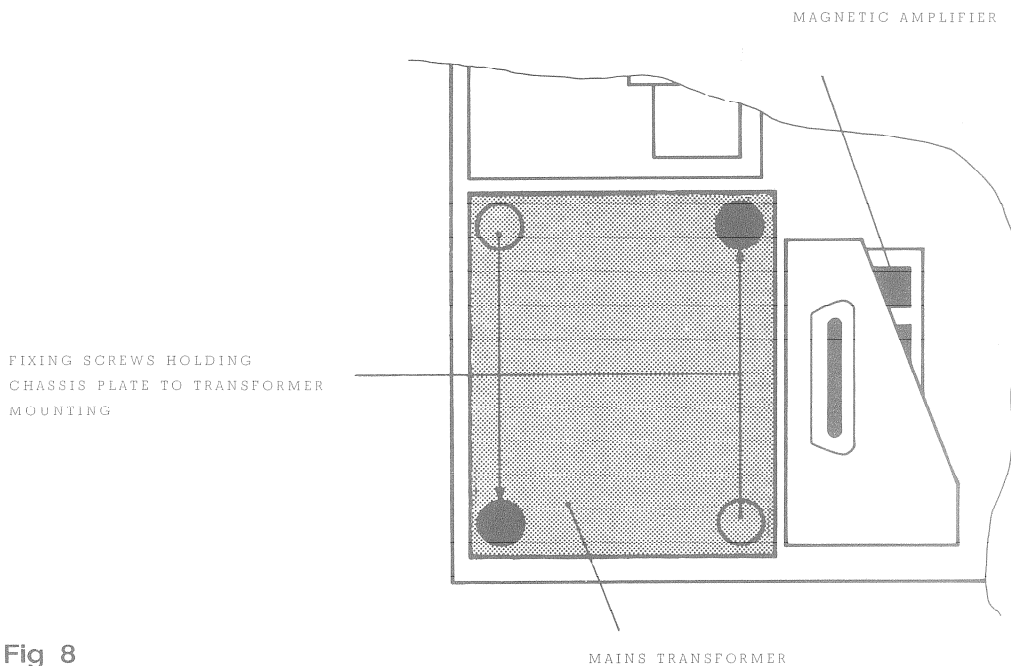

Fig 8

Insert two M 8 x 10 screws into the free screw holes and tighten them up. (In order to secure the heavy mains transformer to the cast spooling deck-plate).

5. Undo the remaining six allen screws C and carefully withdraw the spooling deck. When re-assembling, the six allen screws C must be screwed in firmly before removing the two M 8 x 10 screws.
6. If necessary the back-plate with the mains socket and the motor relay can be removed by undoing the four fixing screws. A guide pin ensures correct positioning when re-assembling.

The back plate can be removed without taking the machine out of its case.

C. 3 DECK PLATE

The two tape tension arms (jockey arms) with their associated damping pistons are built into the deckplate. All other tape guide elements are mounted on the capstan deck.

These jockey arms serve the purpose of smoothing transitory changes in tape tension which occur when starting the tape and due to splices going through.

The piston damping of the jockey arms can be adjusted from the top of the deckplate (fig. 25). The adjustment for the spring tension becomes accessible by removing the tape guide rollers.

The adjustment of the tape tension arms is described under G. 2.1.

D. Spooling Deck

The spooling deck comprises :

THE SPOOLING MOTORS

THE STOP BRAKES

THE OPERATIONAL BRAKES

MAINS SECTION AND BACK PLATE

D.1 SPOOLING MOTORS

The spooling motors have tubular rotors and provide an even torque, free of pole-flutter. The various operating voltages are shown in the following table.

FUNCTION	LEFT HAND SPOOLING MOTOR	RIGHT HAND SPOOLING MOTOR
Playback	Motor voltage controlled by magnetic amplifier	During the run-up period (app. 0,5 sec) = 220 V After the run-up period = 110 V
FAST REWIND	220 V	30 V (57 V as from Nr. 201)
FAST FORWARD	30 V (57 V as from Nr.201)	220 V

D.2 STOP BRAKES / EDITING BRAKES

DURING ANY ADJUSTMENTS TO THE STOP BRAKES GREAT CARE SHOULD BE TAKEN NOT TO DAMAGE THE BRAKE BANDS. THE BRAKE BANDS AND LININGS SHOULD ONLY BE TOUCHED WITH GLOVES WHICH ARE FREE OF GREASE.

Fig 9

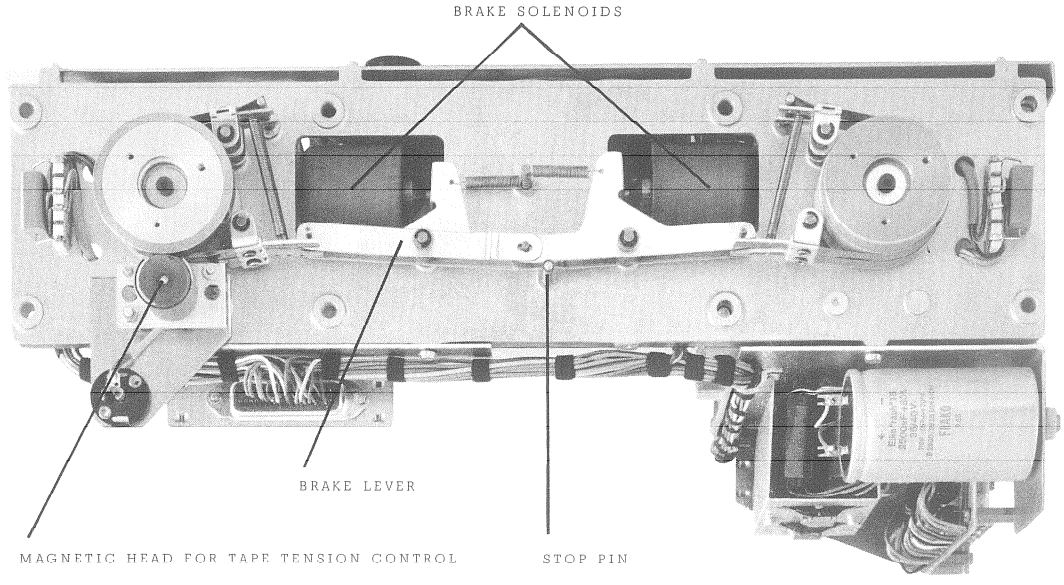

A MAGNETIC TAPE WITH PULSES RECORDED ON IT IS FIXED TO THE LEFT HAND BRAKE DRUM. DURING MAINTENANCE WORK IN THE VICINITY OF THIS DRUM SPECIAL CARE IS NECESSARY TO AVOID BRINGING MAGNETISED TOOLS INTO CLOSE PROXIMITY WITH THIS DRUM.

D.2.1. ADJUSTMENT OF BRAKING TORQUES

The braking torque is 500 gcm (8½ oz. inch) per brake band. In the "Stop" position, the total braking torque is therefore 1000 gcm (17 oz. inch), in the editing position only the lower brake band is in use and the torque is therefore 500 gcm (8½ oz. inch). In order to measure the braking torque a string should be wound over a spool with a centre diameter of 10 cm (4") and the free end attached to a tension gauge (fig 10). One brake should resist a pull of max. 100 g (4 oz.) (editing), both brakes together a pull of 200 g (8 oz.) (Stop) .

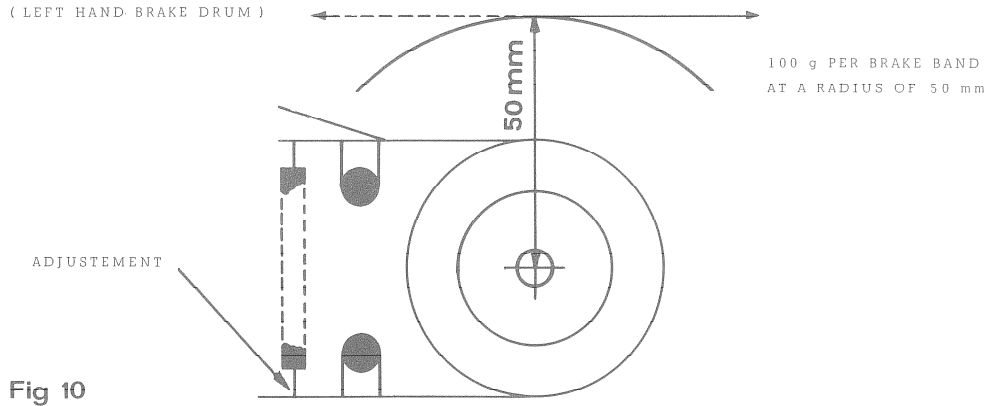

Fig 10

D.2.2. REMOVING OF THE BRAKE DRUMS

The height of the brake drums, on which the spooling plates are fixed, can be adjusted by means of spacers between the brake drum and the spooling motor.

BEFORE LOOSENING THE BRAKE DRUMS IT IS ABSOLUTELY NECESSARY TO DISENGAGE THE BRAKE BANDS. THIS IS BEST ACHIEVED BY JAMMING A PIECE OF WOOD OR PLASTIC BETWEEN THE STOP PIN AND THE BRAKE LEVER (FIG 9).

The brake drums are held onto the motor shaft by means of a collet. The brake drums can be taken off by loosening the allen screw in the centre.

Due to the small cone angle of the collet it is possible that a brake drum might stick so that it cannot be pulled off by hand. In this case, a simple pulling device in accordance with fig 11 will suffice.

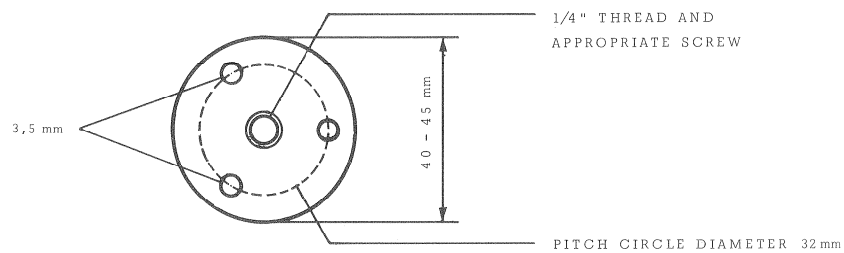

Fig 11

This pulling jig should be screwed onto the brake drum after undoing the allen screw. Tightening up the central 1/4" screw will lift the brake drum off.

D.3 OPERATIONAL BRAKES

D.3.1. BRAKING DURING FAST WIND

As can be seen from the table in the section on " SPOOLING MOTORS " (D.1.) the take-off spool is electrically braked during " playback " as well as during " fast wind ". The braking is effected by means of AC producing a counter torque.

During "fast wind" the braking voltage is 30V (57V as from No. 201). The resulting counter torque is sufficient to achieve tight winding.

D 3.2. TAPE TENSION ADJUSTMENT

During "record" and " playback " the braking voltage to the supply motor is controlled in such a way as to maintain a tape tension within 10% of the nominal (see section G.1.) for spooling diameters between 50 mm and 265 mm (2 3/8" and 10 1/2").

The braking voltage is controlled by the angular velocity of the left-hand spooling plate. This servo-control method has the advantage that there is no error quantity to be fed back.

The above mentioned magnetic tape on the left-hand brake drum is modulated with pulses (Agfa PER 555 saturated, 1000 c/s at 15 i.p.s.) A playback head picks these pulses up without touching the tape. (Fig 9) The resulting pulse frequency varies in accordance with the spooling diameter and the tape speed between 20 and 1,200 c.p.s.

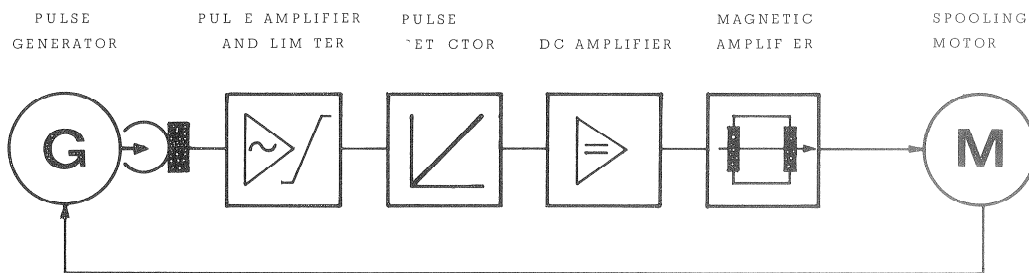

Fig 12

The AC amplifier amplifies and limits these pulses. The subsequent discriminator charges an electrolytic condenser. The voltage across the electrolytic condenser is amplified and then taken to a DC-push-pull amplifier which in turn provides the control voltage for the magnetic amplifier.

The zener diode in parallel with the condenser only operates in the case of very small spooling diameters.

The tape tension control can be adjusted by means of the potentiometers P. 1 and P. 2.

Detailed instructions for this adjustment will be found under "ADJUSTMENTS AND ALIGNMENT PROCEDURE' G.

The tape tension control is constructed as a plug-in unit. (On machines with pilot tone head, this plug-in unit also contains the associated circuitry). The magnetic amplifier is mounted together with the mains section below the left-hand spooling motor.

D.4 MAINS SELECTION

The mains section contains a transformer which provides the various voltages required by the machine. This transformer is mounted below the left-hand spooling motor. The precision fuses for the secondary windings are mounted on an printed circuit board.

The primary winding of the mains transformer is tapped for the following voltages :

110 / 117 / 125 / 150 / 220 / 250 Volts

The mains transformer has the following secondary windings :

2 x 21 V	for the stabilisers (+ 15 V and - 15 V DC)
20.5 V	for the relay circuit (full wave rectifier)
30 V	for the braking voltage during fast wind
57 V	for the braking voltage during fast wind (as from Nr. 201)
110 V	for the spooling motors (operating voltage)
145 V	for the magnetic amplifier (tape tension control)
160 V	for optional increased tape tension (as from No. 201)
220 V	for the capstan motor and the spooling motors (fast wind)

The fuses in the secondary circuit (slo-blo) have the following values :

F 3	1	A	Spooling motors
F 4	.5	A	Capstan motor
F 5	.5	A	Stabiliser for +15 V
F 6	1	A	Stabiliser for -15 V
F 7	3.15	A	Relay supply (full wave rectifier)

Both sides of the primary are fused. The fuses (slo-blo) are situated on the back of the plastic part of the voltage selector.

(F 1 and F 2 each 1 A at 220 V or 2 A at 117 V)

The mains switch is mounted on the capstan deck. This switch also switches the speed of the capstan motor. Cams on the shaft of the switch operate two micro switches. The switching sequence is arranged in such a way that the poles of the capstan motor are never switched while there is current in the windings.

The stabilisers for the voltages of + 15 V and - 15 V are part of the mains section. They are constructed as plug-in units and are described in detail in section F.3.

E. Capstan Deck

The Capstan deck comprises :

HEADBLOCK
TAPE GUIDE ELEMENTS
END OF TAPE SWITCH
PUSH BUTTON UNIT
CAPSTAN MOTOR ASSY.
PINCH WHEEL MECHANISM
TIMING INDICATOR

E.1 HEADBLOCK

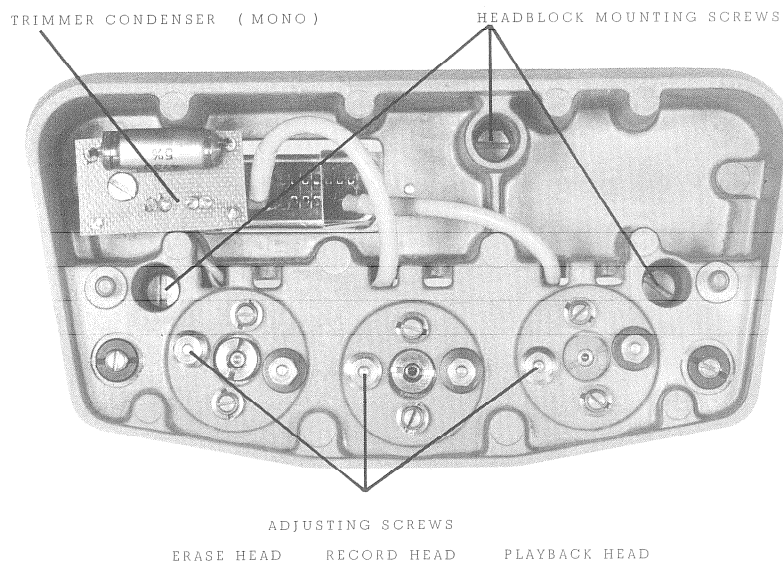

Fig 13

The headblock is an aluminium casting which is screwed to the capstan deck, resting on it in three points. All connections are made via a 24 pole AMPHENOL plug. They are sufficient spare contacts for stereo headblocks and special versions with pilot tone, etc.

BEFORE MOUNTING THE HEADBLOCK THE MACHINE SHOULD BE SWITCHED OFF IN ORDER TO AVOID MAGNETISING THE HEADS DUE TO POSSIBLE CURRENT SURGES. *IT IS ADVISABLE TO DE-MAGNETISE THE HEADS AND THE TAPE GUIDES EVERY TIME ANY WORK HAS BEEN CARRIED OUT ON THE HEADBLOCK.

To avoid pick-up of stray magnetic fields, the record and playback heads are provided with Mu-metal screening cans. To maintain the height of the tape accurately, special tape guides with wear resistant guide discs are fitted before the erase head and behind the playback head. The internal width of the tape guides is 6.3 mm (.248") corresponding with the standard tape width.

The fixing screws of the headblock and the adjustment screws for the heads are accessible by lifting off the cover plate. Behind the erase head is also the tuning capacitor for the erase oscillator. Only this capacitor should be altered when adjusting the oscillator frequency. The frequency should be set to 80 kc/s + 300 / - 0 c/s (MONO).

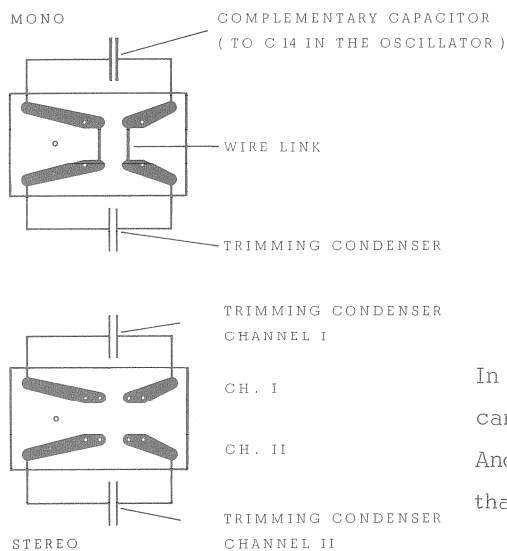

In the stereo headblock the printed circuit card contains one capacitor for every channel. Another difference from the mono version is that there are no wire links.

Fig 14

E. 1.1 HEAD MOUNTINGS

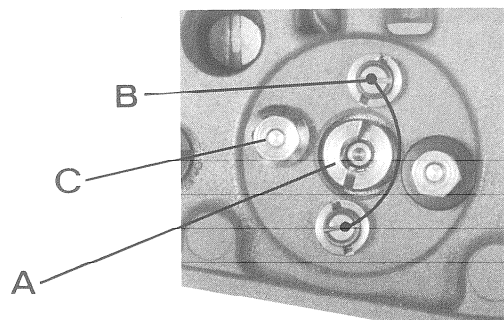

Fig 15

The heads are adjusted by means of five screws. The function of these screws is as follows :

- A: The screw "A" in the centre is the head fixing screw. It should only be removed when changing the head or if the head is to be turned round its vertical axis.

- B: The two screws "B" are for aligning the head face to the plane of the tape. The front screw is for setting the height, the one at the back for adjusting the vertical.
- C: The hexagonal nut "C" is for the azimuth alignment. The head gap should be at right angles to the tape path. This adjustment is done as described under section G.4.2. + G. 5.1.

E. 2 TAPE GUIDE ELEMENTS

All the tape guide elements with the exception of the tension (jockey) arms are mounted on the capstan deck. The left-hand and right-hand guide rollers are rigidly mounted, the fly-wheel pulley and the pressure roller are mounted on pivot arms. The left-hand guide roller works the end of tape switch and the right hand roller drives the timing indicator.

The adjustment of the tension arms is described in detail in section G. 2.1. The height adjustment of the tape guides and the heads is with reference to the points on the deck upon which the head block locates.

E. 3 END OF TAPE SWITCH

The end of tape switch is an electro-dynamic device without any tension arms or contacts. The left-hand guide roller drives a sprocket wheel which varies the magnetic field in a coil. The arrangement is such that no pole flutter is produced which might cause flutter in the tape.

The induced voltage is amplified in a first stage and rectifier and amplified in a second stage so that the relay RS is energised as long as the tape is running. (See top left-hand corner of the circuit diagram of the deck unit).

(Note adjustment of relay RS ! The contact 9/10 close before 5/6 opens)

The two diodes across the base resistance of the input stage prevent a shift in operating point when the stage is over-driven (fast wind).

To prevent the machine from being switched off immediately, as soon as it is remote started from a fader contact (remote control), cancelling all other controls) a positively charged storage condenser is switched onto the base of the second amplifier stage by means of a "make" contact on the relay RF.

E
2
3

The printed circuit card with the end of tape switch is right beside the left-hand guide roller on the capstan deck. On the same circuit card is also the series resistance for the function indicator lamp. The relay RS is mounted on the push-button unit.

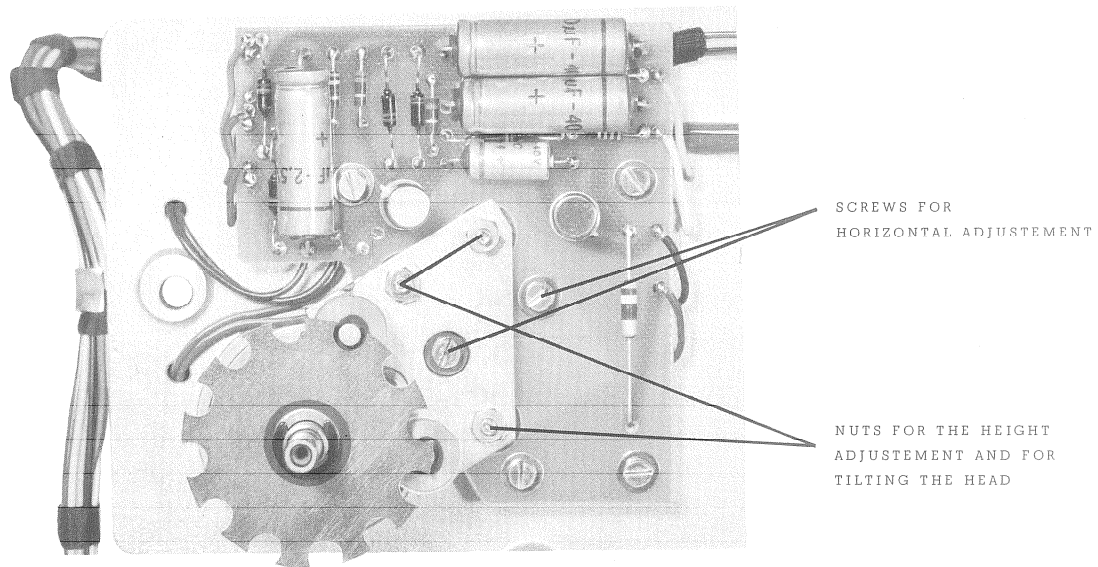

Fig 16

E. 3.1 END OF TAPE SWITCH - COIL ADJUSTMENT

If, in the course of servicing, the end-of-tape switch has been dismantled, the induction coils have to be adjusted after re-assembly.

Accurate adjustment of these coils will prevent pole flutter which might be transmitted to the tape.

By means of the slotted screws, the induction coils can be horizontally adjusted in such a way that on one side a core will be exactly between two cut-outs of the disc and on the opposite side a core will be opposite a cut-out. (See fig 16) The adjustment can be checked by turning the disc through half the diameter of a core. The inner side of the circular cut-outs should then be exactly over the centres of the cores.

The height of the coil cores and of the magnet core should be adjusted by means of the hexagonal nuts until they are equidistant from the disc. Finally the pole faces should be parallel to the disc and the clearance should be set to .4 mm (.016") by means of a feeler gauge.

E. 4 PUSH BUTTON UNIT

The push-button unit is mounted on an printed circuit board. The push-button assemblies directly contact a gold-plated contact rail. All the relays for the tape transport mechanism are mounted on the printed circuit board and are marked. The associated circuit elements such as diodes, resistors and condensers are also mounted on this board.

Two types of relays are used :

4 changeover contacts	Siemens	Trls 154 d	65.421 / 93 e
2 changeover contacts	Siemens	Trls 154 c	65.422 / 93 d

The relay RS is specially adjusted : see under E.3.

All relays have an operating voltage of 24 V.

WITH REMOTE AND EXTERNAL CONTROL OF THE RELAY RF THIS RELAY SHOULD BE SUBSTITUTED WITH AN APPROPRIATE ONE IF A SUPPLY VOLTAGE OTHER THAN 24 V IS TO BE USED.

The motor relays are mounted on the backplate. (See C. 2.4.6.)

E. 5 CAPSTAN MOTOR ASSY.

The procedure for removing the capstan motor assy. is described under C.2.3.

The Hysteresis-synchronous motor, the fly-wheel and the capstan with bearing form a separate sub-assembly.

The synchronous motor can be switched to 6-pole and 12-pole operation for the two tape speeds. The motor is coupled to the fly-wheel by means of an elastic non-slip coupling.

The capstan is lubricated for its lifetime. If replacement becomes necessary, the capstan should be replaced complete with bearing plate. For removing the capstan-bearing plate unit the elastic coupling must be unscrewed. Furthermore, the four guide pins should be unscrewed: the bearing plate and the fly-wheel can then be withdrawn. The fly-wheel can be removed by loosening the 11 mm nut in the centre.

WHEN RE-FITTING THE FLY-WHEEL THE PLASTIC WASHER MUST BE REPLACED UNDER THE 11 MM NUT. THIS NUT SHOULD BE DONE UP LIGHTLY AND THEN SECURED WITH A DROP OF VARNISH. (IF IT IS TIGHTENED UP TOO MUCH THE CAPSTAN MAY BE DISTORTED.) GREAT CARE SHOULD BE TAKEN DURING ASSEMBLY NOT TO DAMAGE THE CAPSTAN BY KNOCKING IT.

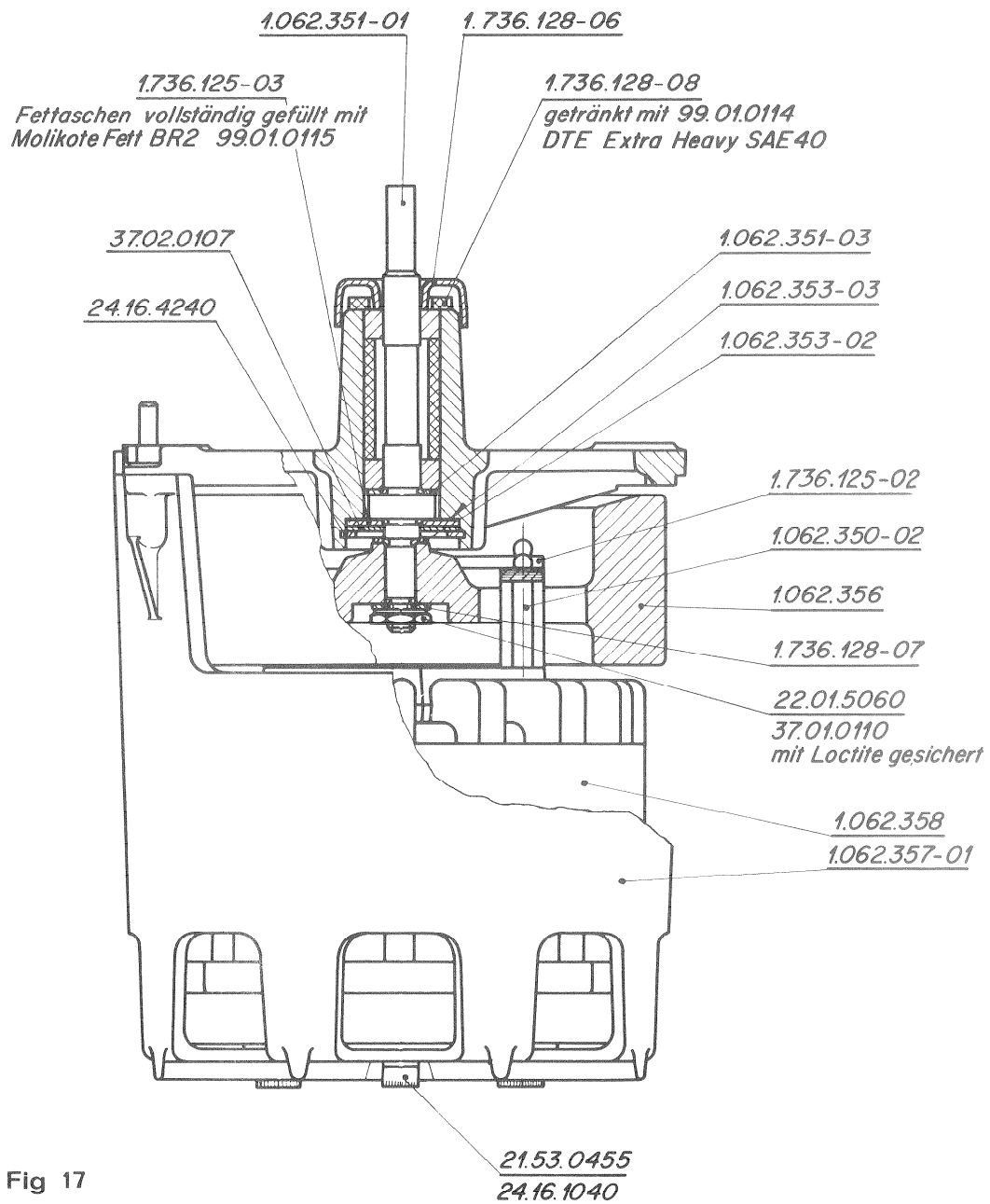

E
5

Fig 17

When checking the capstan for ovality the pinch wheel should be engaged to avoid errors due to the bearing play. The maximum permissible clock reading is $1 \mu\text{m}$ ($1/1000 \text{ mm}$) ($.04 \text{ mil}$).

E. 6 PINCH WHEEL MECHANISM

The pinch wheel mechanism moves the pinch wheel and the fly-wheel pulley. There are two operating positions. The adjustments are made by means of spacers behind the solenoids.

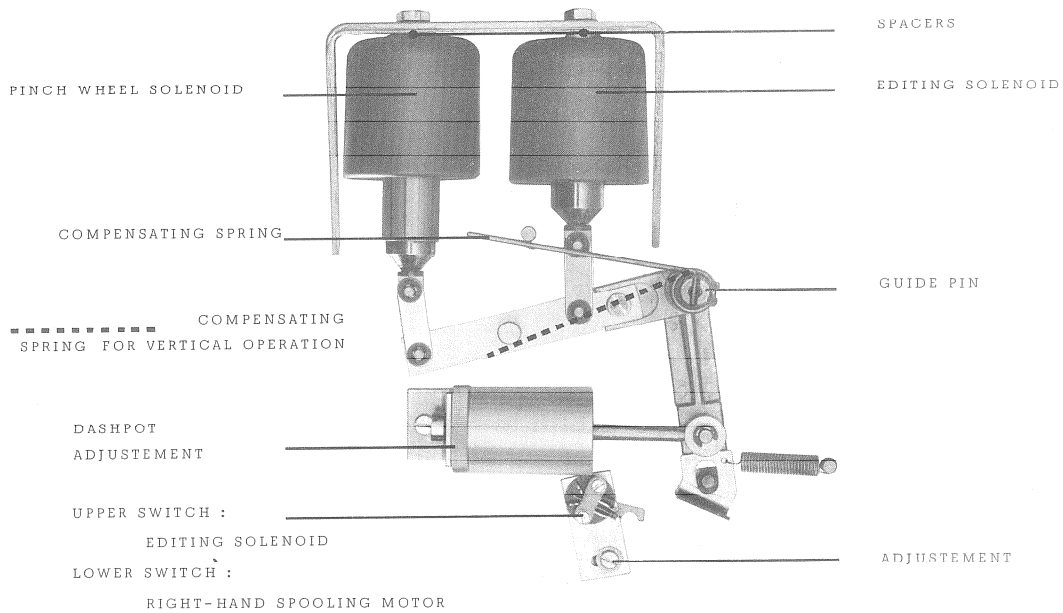

Fig 18

The editing solenoid should be adjusted in such a way that the tape comes into contact with the heads but does not touch the capstan when the solenoid is energised.

The pinch wheel solenoid should be adjusted so that the fly-wheel pulley lags app. 1 mm when the pinch wheel is in contact with the capstan. This lag can be checked by pressing the pinch wheel against the capstan by hand then pressing the playback button. The rubber pressure roller should press against the capstan (measured radially in the direction of the capstan) with a pressure of app. 1700 g (3.75 lbs).

The two micro-switches can be adjusted by means of the adjusting screw. The upper micro-switch cuts the editing solenoid out in the "playback" position. The lower micro-switch is for the delayed switching of the right-hand spooling motor.

The switches should be adjusted so that the editing solenoid is cut out as soon as the pressure roller touches the capstan. The two micro-switches are rigidly connected together so that the right-hand spooling motor is switched on just before the editing position is reached when the adjustment is correct.

The adjustment of the dashpot is part of the "Start" adjustment and is described in section G. 2.2.

E. 6.1 MOUNTING POSITION

If the machine is mounted vertically, the compensating spring should be changed to the position shown in fig 18. This will compensate the additional weight on the pinch wheel mechanism.

If the deck is mounted at an angle and exact-compensation cannot be achieved by turning the spring over, it is possible to achieve intermediate compensations by loosening and turning the pivot pin.

The compensating spring shown in fig 19 for the reset mechanism for the timing indicator should also be hooked in for vertical operation.

E. 7 TIMING INDICATOR

The reading of the timing indicator is described in section B.9.

The timing indicator can be removed from the underneath side without removing the capstan deck. All that is necessary is to remove the guide roller, the dashpot and the fixing screws.

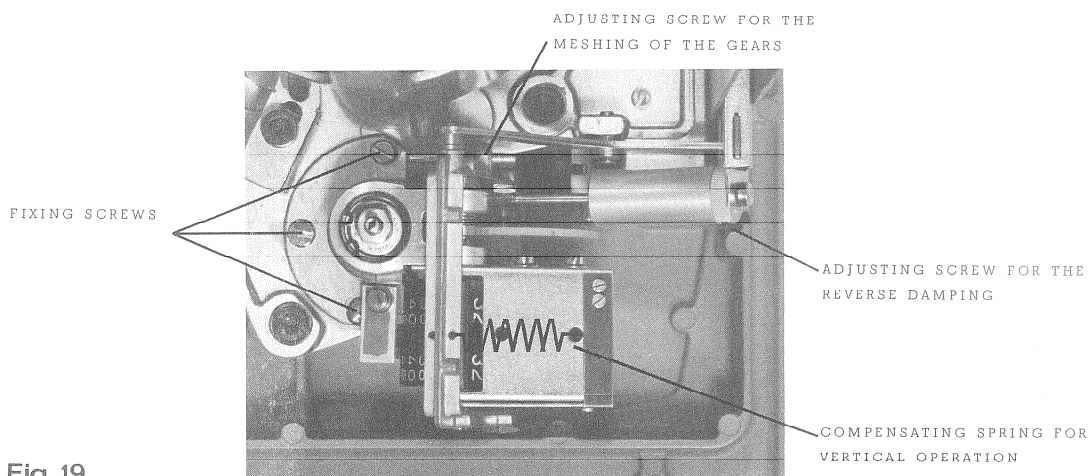

Fig 19

The reverse damping should be adjusted by turning the adjustment screw (worm screw) slightly in such a way that the number discs are not turned out of position when going in reverse from zero.

THE DASHPOT ARE DRY LUBRICATED WITH MOLYKOTE G AND NEED NO SERVICING.

F. Amplifier Frame

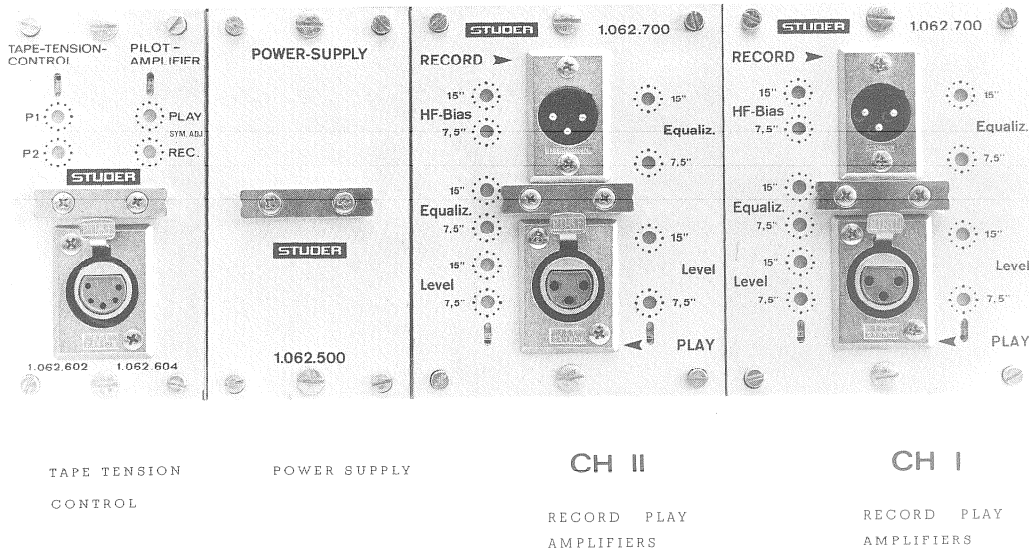

Fig 20

BEVORE PLUGGING THE AMPLIFIER UNITS IN OR OUT THE MACHINE SHOULD BE SWITCHED OFF, OTHERWISE THE RESULTANT CURRENT SURGES MIGHT MAGNETISE THE HEADS.

F.1 RECORD AMPLIFIER

The record amplifier is housed in the same plug-in unit as the playback amplifier. Looking at it from the front-plate, the record amplifier is on the left printed circuit plate ("Record"). The upper CANNON connector (XLR-3-32) is the input to the record amplifier.

The record printed circuit card contains a balanced input transformer, plug-in equalisers, three plug-in relays :

RLA	Siemens	Trls	162 b	65.421 / 119 e	Switching of	equalisation	7,5"/15"
RLAO	Siemens	Trls	162 a	65.422 / 119 d		bias	
RA	Siemens	Trls	162 a	65.422 / 119 d		Oscillator	

and the record amplifier itself and the Oscillator.

The input signal goes via the balanced transformer and the two potentiometers (LEVEL) P 1 (15") or P 2 (7 1/2") to the four-stage direct coupled equalisation pre-amplifier. When the relays RLA and RLAO are not energised they are set to 15". The components for the equalisation are housed in a can (7-pole miniature socket) and are interchangeable. The two potentiometers P 3 and P 4 (EQUALIZATION) enable the treble to be adjusted to suit the particular brand of tape in use. (G.5.4.)

The push-pull output stage drives the record head via an LC-filter (blocking the oscillator frequency of 80 kc/s). The two potentiometers P 5 and P 6 (HF-BIAS) are for adjusting the bias.

The adjustment of the :

RECORD GAIN (LEVEL)	P 1, P 2,	is described under G.5.3.
EQUALISATION	P 3, P 4,	is described under G.5.4.
BIAS (HF-BIAS)	P 5, P 6,	is described under G.5.2.

F.1.1 OSCILLATOR

The push-pull oscillator is switched click free by means of a switching transistor. The switching transistor is controlled by the trigger voltage from the relay RA, the switching -on time constant (app. 60 μ sec) being controlled by the resistor R 26 and the electrolytic condenser C 16. The output of the oscillator is coupled to the tuned circuit L 3 / C 14.

WHEN TUNING THE OSCILLATOR FREQUENCY, C 14 MUST NOT BE ALTERED. ONLY THE CAPACITORS IN THE HEADBLOCK SHOULD BE TRIMMED. (SEE ALSO UNDER E 1)

If this point is adhered to, the headblock and the plug-in amplifier units can be interchanged without affecting the oscillator frequencies.

The oscillator frequency is 80 kc/s. The frequency should be adjusted when the machine is cold to a tolerance of + 300 c/s; -0 c/s (MONO). With stereo and two track operation the oscillators synchronise via the coupling in the erase head. When adjusting the oscillator frequency both channels should be adjusted separately to the same frequency.

Note : The individual frequencies are higher than the nominal frequency as the effective frequency is reduced due to the coupling in the erase head.

F. 2 PLAYBACK AMPLIFIER

The playback amplifier is housed in the same cassette as the record amplifier. Looked at from the front plate the playback amplifier is on the right-hand printed circuit card (PLAY). The lower CANNON connector (XLR - 3 - 31) is the output of the playback amplifier.

The playback printed circuit card contains a balanced output transformer, plug-in equaliser units and a relay for switching the equalisation :

RLW Siemens Trls 162 b 65.421 / 119e

for switching the equalisation.

The amplifier has two sections, the playback amplifier with plug-in equalisation and the line amplifier.

The output from the playback head goes to a three stage direct coupled playback amplifier. The equalisation is switched automatically by means of the relay RLW to the tape speed in use.

The desired output levels can be set by means of the potentiometers P 1 (7½") and P 2 (15") at the input to the line amplifier. (.7 - 4.4 V). The potentiometers P 4 and P 5 lie in the feed-back path and provide an additional treble control. The particular feature of the "single ended push-pull" output stage is that the output is not mixed with DC thereby simplifying the design of the transformer output stage. As the amplifier is direct coupled throughout the operating point of the output stage can be set up from the input.

The adjustment is carried out by connecting a sensitive volt-meter between the output (TEST POINT) and chassis. Turn the level control right down (or short out C 22) and adjust P 3 for zero voltage.

The adjustment of the :

PLAYBACK LEVEL P 1, P 2 is described in section G. 4. 1.

EQUALISATION P 4, P 5 is described in section G. 4. 3.

F. 3 STABILISED POWER SUPPLY

Two identical stabilisers for the supply voltages of + 15 V and - 15 V are housed in one plug-in unit.

The two silicone bridge rectifiers are each fed with 21 V AC from separate windings of the mains transformer. The electronic voltage stabilisation uses a power transistor (ASZ 18) as series resistor. A reference voltage from a zener diode (ZF 7,5) is fed to the base of the first control transistor. The control voltage is obtained from a potential divider P 1 . The output voltage of 15 V can be adjusted by means of P 3 .

The stabilised output voltage is $15 \text{ V} \pm .1 \text{ V}$ (400 - 600 mA).

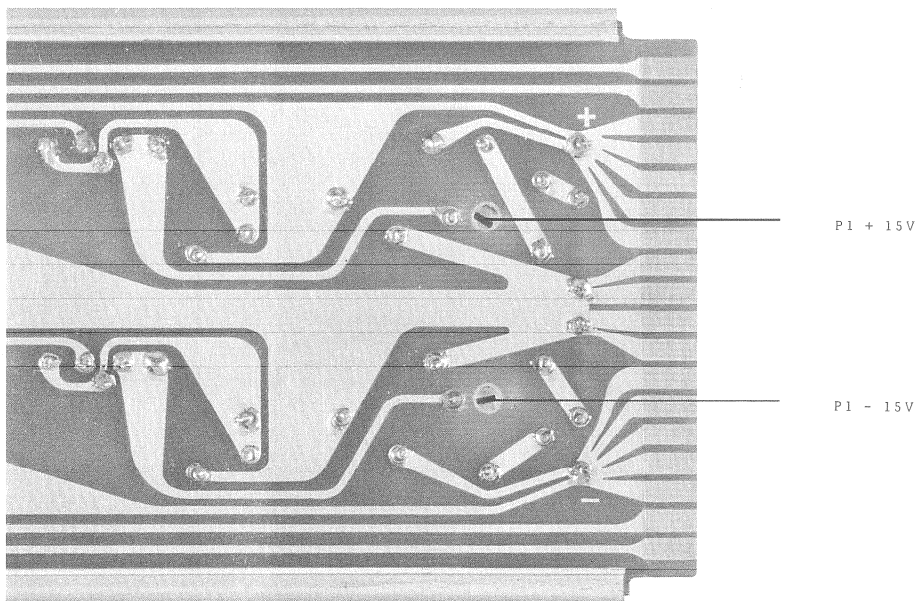

Fig 21

F.4 TAPE TENSION CONTROL

The operation of the TAPE TENSION CONTROL is described under D. 3.2.

The adjustment of the TAPE TENSION CONTROL is described under G. 1.

A relay of the type:

Siemens Trls 154 c 65.442 / 93 d

is mounted on the printed circuit card. The version with pilot tone head has the associated circuitry housed in the same cassette with the tape tension control.

G. Adjustments and Alignment Procedure

BEFORE ANY ELECTRICAL MEASUREMENTS WITH MOVING TAPE THE ADJUSTMENT OF THE TAPE TENSION CONTROL AND THE TAPE START SHOULD BE CHECKED AND IF NECESSARY ADJUSTED.

G.1 TAPE TENSION CONTROL

The operation of the tape tension control is described in section D.3.2.

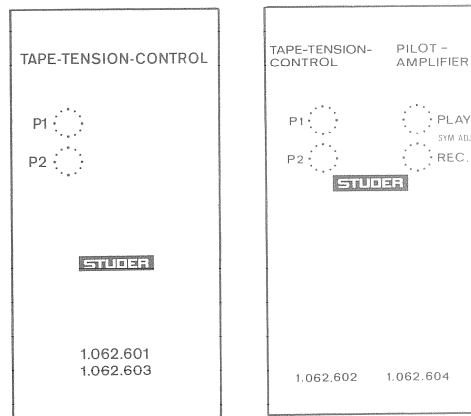

Fig 22

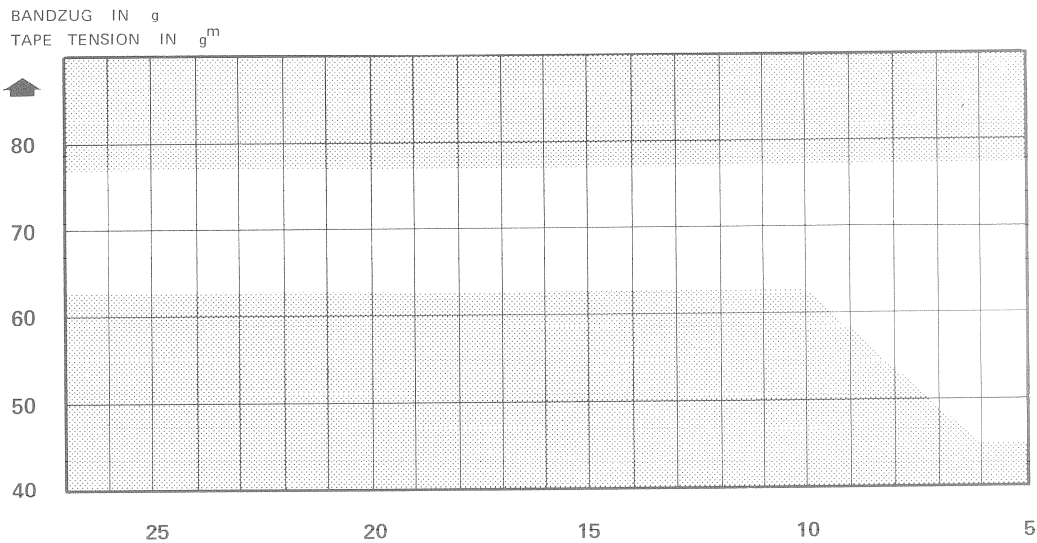

Fig 23

← SPOOLING DIAMETER IN cm
SPULENDURCHMESSER IN cm

The adjustment is carried out as follows: (15")

1. P. 2 should be turned almost fully anti-clockwise.
2. Place a large spool with a tape spooling diameter of 10" onto the left-hand spooling plate. Adjust for a tape tension of app. 70g (2½ oz.) by means of P 1.

3. Measure the tape tension for a spooling diameter of 4" and adjust for 70 g (2½ oz.) by means of P2.
4. Repeat point 2 and 3 until the tape tension values correspond with fig 23.
5. Place a very small spool with a spooling diameter of 5 cm (2 ") onto the left-hand spooling plate and check tape tension. If the tape tension is outside tolerance, the left-hand spooling motor and the functioning of the zener diode in the pulse discriminator circuit should be checked.
6. Check the tape tension at the lower speed with a medium spooling diameter. If the tension is outside tolerance replace C5 (C 15).

G.2 TAPE START

G.2.1 TAPE TENSION ARMS

The return springs of the tape tension (jockey) arms should be hooked into the appropriate hole to obtain the tension values measured with a gauge as shown in fig. 24.

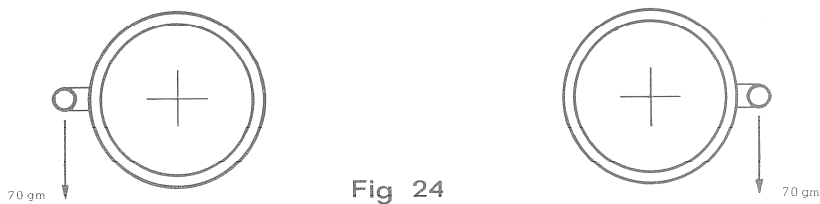

Fig 24

The dashpot should be adjusted by means of the worm screws (fig 25) to obtain a return time of app. 5. seconds.

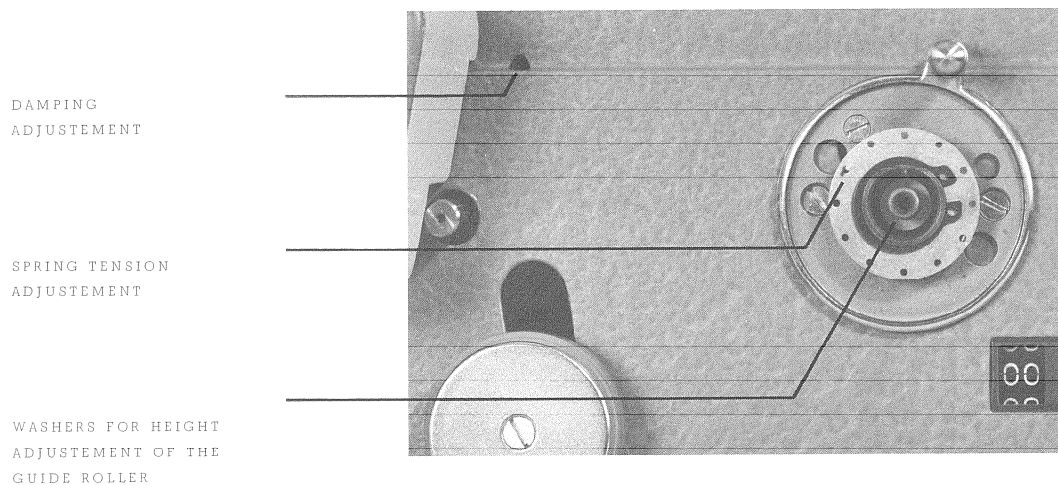

Fig 25

G.2.2 DAMPING OF PINCH WHEEL MECHANISM

The damping of the engagement of the pressure roller should be adjusted by means of the knurled disc on the dashpot (fig 18) so as to avoid oscillations when going into the editing position. However, the pressure roller should not engage sluggishly.

G.2.3 STARTING TIME

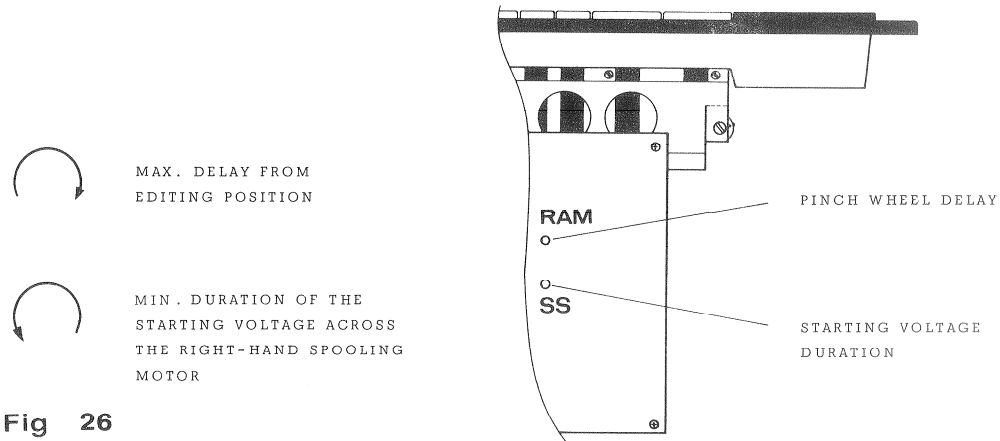

Fig 26

The upper pre-set control is for adjusting the delay of the pressure roller solenoid. The delay should be turned back from maximum until the movement appears continuous when the pressure arm moves into the 'play' position. (app. 0.2 seconds).

The lower pre-set control is for adjusting the duration of the starting voltage (200 V) on the right-hand spooling motor. This time should be increased from the 'min time' position until no loop is thrown on the right-hand side with a large spooling diameter (2,400 ft of tape).

It is important to ascertain that the right hand tape jockey arm which compensates the tape movement does not hit its stop. If necessary the damping of the jockey arm should be adjusted.

G. 3 ELECTRICAL ADJUSTMENTS AND MEASUREMENTS

G. 3.1 GENERAL CONSIDERATIONS

The purpose of the electrical adjustments is in general to achieve a good compromise between distortion and signal-to-noise ratio while maintaining a frequency response within tolerances. For this purpose the frequency response of the record and playback amplifiers is such as to obtain a flat overall response. In order to achieve compatibility the playback response is standardised through international convention. The record frequency response is not standardised. It has to be adjusted in such a way as to obtain a flat overall response with the particular tape and amount of bias used. The most usual standard in Europe is CCIR while in the U.S.A. many machines use the NAB characteristic. The STUDER A 62 uses normally the CCIR characteristic but it can be supplied with NAB equalization. The plug-in equalizers enable the machine to be converted quickly from one standard to another. It is also possible to use special equalizations with different frequency characteristics simply by plugging in a special set of equalizers.

Quite generally a tape recorder is adjusted by first aligning the playback channel by means of a test tape to a standard. Subsequently, the record channel is adjusted in such a way as to obtain a flat overall response with the particular type of tape in use. The test tape has a section with a reference level for adjusting the playback level, a frequency response section and an azimuth alignment tone.

WHEN ADJUSTING THE AZIMUTH IT IS IMPORTANT TO ENSURE THAT THE GAPS OF ALL TAPE RECORDERS ARE ABSOLUTELY VERTICAL TO THE TAPE PATH. THIS IS THE ONLY WAY TO ENSURE A CORRECT HIGH FREQUENCY RESPONSE IN THE USUAL PROGRAMME INTERCHANGE.

WHERE NOT OTHERWISE MENTIONED, THE ADJUSTMENTS ALWAYS APPLY TO ONE CHANNEL AND SHOULD OF COURSE BE CARRIED OUT EQUALLY FOR THE SECOND CHANNEL.

G.3.2 TEST INSTRUMENTS

Signal generator with less than $\leq .5$ % distortion

LF-millivoltmeter, e.g. SIEMENS & HALSKE Rel U 33 for signal-to-noise measurement.

Wow and flutter meter EMT 420 or WOELKE ME 102

Wave analyser or Distortion measuring instrument with band pass 30 c/s to 20 kc/s.

Test tapes for 7 1/2 and 15 i.p.s. (with appropriate equalisation).

De-magnetiser

Wave analyser or 1000 c/s band pass filter for measuring erasure and cross talk.

G.4 PLAYBACK CHANNEL

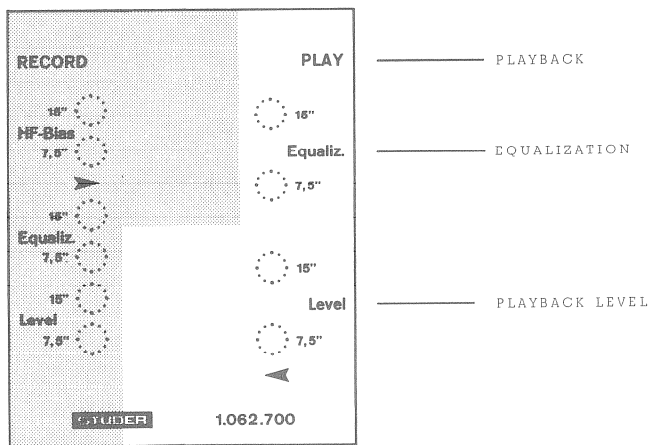

Fig 27

THE HEADS AND TAPE GUIDES ARE TO BE DE-MAGNETISED WITH THE MACHINE SWITCHED OFF.

If the de-magnetiser is fed from a variac it is possible to remove the last traces of magnetism reliably by slowly and evenly reducing the voltage.

G
3
4

G.4.1 SETTING UP OF LEVEL

- Run the test tape at the appropriate speed in playback.
- Using the 1000 c/s reference tone section, adjust the playback head for maximum output. Then set output to the desired level (.7 V - 4.4 V) by means of the LEVEL control.

The level adjustments for the different tape speeds are independent of one another.

G.4.2 PLAYBACK HEAD - AZIMUTH ALIGNMENT

The head can be adjusted by means of 5 screws. The function of these screws is explained in section E.1.1.

The azimuth alignment should be carried out with the appropriate section of the test tape (10 kc/s at $7\frac{1}{2}$ i.p.s.). The nut C should be adjusted for maximum output. Subsequently the azimuth adjustment nut should be locked with a drop of varnish.

For the adjustment of stereo heads by the phase method see under G.10.2.

G.4.3 PLAYBACK FREQUENCY RESPONSE

The frequency response section of the test tape should be used which is recorded at a level - 20 db.

- Check that the frequency response is flat and if necessary adjust the high frequency response by means of the appropriate EQUALIZATION control.

For the low frequencies the RW resistor in the equalisation circuit should be adjusted.

G.5 RECORD CHANNEL

BEFORE ANY ADJUSTMENTS ON THE RECORD CHANNEL, THE PLAYBACK CHANNEL MUST HAVE BEEN ALIGNED IN ACCORDANCE WITH SECTIONS G.4.1. TO G.4.3.

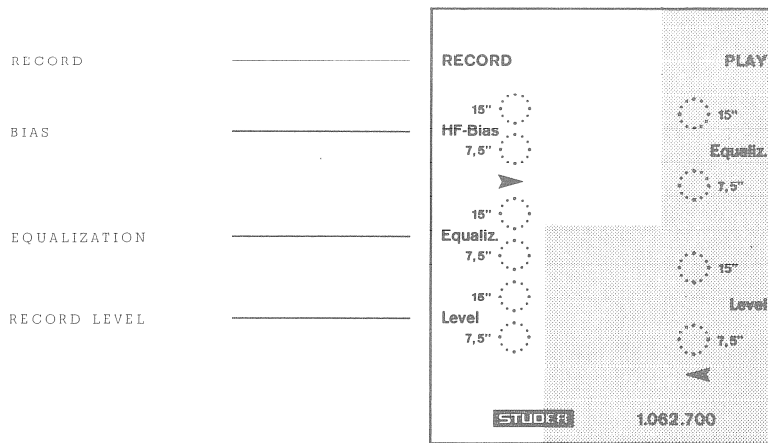

Fig 28

G
5

G.5.1 RECORD HEAD - AZIMUTH ALIGNMENT

- Load a blank tape and switch the machine to record at $7\frac{1}{2}$ i.p.s.
- Feed a 1000 c/s tone at -20 db to the input of the record amplifier. Measure the output of the playback amplifier with a sensitive VTVM. The azimuth alignment of the record head is carried out by means of the nut C as described in section G.4.2.
- The fine adjustment of the azimuth should then be repeated with a 10 kc/s tone.

For the adjustment of stereo record heads by the phase method see section G.10.3.

G.5.2 HF - BIAS (RECORD)

The test certificate which is supplied with the machine will show the type of tape for which the STUDER A 62 was adjusted at the factory. If another type of tape is to be used for recording the bias (and equalisation) should be adjusted to suit this tape.

BEFORE ADJUSTING THE BIAS ALL THE ADJUSTMENTS DESCRIBED UNDER G.4.1. TO G.5.1. SHOULD BE CARRIED OUT OR CHECKED.

When the bias is changed this affects the remanent flux in the tape and thereby the playback voltage, the frequency response and the distortion. The method described below for adjusting the bias gives a good compromise between these factors.

When tapes with special characteristics are used such as high output tapes other methods may be used for adjusting the bias which may provide lower distortion or a higher overload margin and thereby a better signal to noise ratio depending on the individual requirements. When setting the bias the recommendations of the tape manufacturer should be followed. If no recommendations are available the bias may be adjusted for modern tape by the following method.

- Load a new tape and switch the machine to record.
- Record a 10 kc/s tone from a signal generator at a level of -20 db.
- Measure the output voltage from the playback amplifier by means of an LF-millivolt-meter (VTVM)
- Turn the HF-BIAS control for the tape speed in use from the min. position (fully anti-clockwise) slowly in a clockwise direction.
- For the tape speed of 7 1/2 i.p.s. the HF-BIAS 7.5 " control) should be turned up until the output voltage reaches a maximum.
- For the tape speed of 15 i.p.s. the HF-BIAS 15 " control should be turned further in a clockwise direction beyond the maximum output position until the output level has fallen by 2 db.

The two HF-BIAS controls are mutually independent.

G.5.3 LEVEL ADJUSTMENT

In order to obtain a good signal-to-noise ratio, the tape should always be fully modulated by programme peaks. The level of the playback amplifier was adjusted as described in section G.4.1 with a fully modulated tape. The gain control on the record amplifier should be set in such a way as to ensure fully modulated tapes. The minimum input voltage for this purpose is 200 mV.

- Switch the machine to record at the appropriate tape speed using a reel of blank tape.
- Measure the output of the playback amplifier with a VTVM.
- Feed 1000 c/s tone at the intended input level to the input of the record amplifier.
- Adjust the LEVEL control for the appropriate tape speed in use in such a way as to obtain the same output level from the playback amplifier as set up in section G.4.1.

THE LEVEL CONTROL OF THE PLAYBACK AMPLIFIER MUST NOT BE RE-ADJUSTED FOR THIS PURPOSE.

G.5.4 FREQUENCY RESPONSE "VIA TAPE"

- Switch the machine to record at the appropriate tape speed using a reel of blank tape.
- Measure the output of the playback amplifier with a VTVM.
- Feed a 1000 c/s tone to the input of the record amplifier and adjust the level until an output of 20 db below peak is reached.
- Feed a 12 kc/s tone at the same level into the record amplifier and adjust the appropriate EQUALIZATION control on the record amplifier until the output level is the same as at 1000 c/s (-20 db).

THE SETTING OF THE EQUALISATION CONTROL ON THE PLAYBACK AMPLIFIER MUST NOT BE RE-ADJUSTED.

G.6 DISTORTION MEASUREMENTS

When all the above mentioned adjustments have been carried out, the distortion via tape may be checked. The way the distortion is measured depends very largely on the type of distortion meter used and cannot, therefore, be described here in detail.

The distortion produced by the tape consists mainly of odd harmonics, chiefly the third harmonic. The distortion of the amplifiers which is as a rule well below the tape distortion level consists as a rule of even harmonics. The minimum distortion which can be achieved is largely a function of the recorded level and the type of tape used.

G.7 SIGNAL - TO - NOISE RATIO - MEASUREMENT

BEFORE MEASURING THE SIGNAL-TO-NOISE RATIO THE HEADS AND THE TAPE GUIDES SHOULD BE DE-MAGNETISED AS DESCRIBED IN SECTION G.4.

In order to obtain standard test results the measurements should be carried out with the above mentioned meter Siemens Rel U 33. The tape which is to be used for this measurement should be erased beforehand.

Electrical equipment with strong stray magnetic fields such as fluorescent lamps should be removed from the immediate vicinity of the machine for this measurement.

- The playback noise voltage is measured with the machine running and the left-hand spooling motor revolving slowly.
- For noise measurement 'via tape' the pre-erased tape should be loaded and the machine switched to record. The input to the record amplifier should be shorted out. This silent recording is then rewound and the noise voltage is measured in the playback position.

G.8 ERASURE

For measuring the erasure a 1000 c/s band pass filter or a frequency analyser is required.

- The test tone (1 kc/s) is recorded and rewound and the tape is then run through a second time in the record position this time with the record amplifier input shorted and the residual 1 kc/s component is measured.

The maximum obtainable erasure depends on the alignment of the erase head and on the frequency of the test tone.

G.9 WOW-AND-FLUTTER AND SLIP MEASUREMENTS

The wow-and-flutter and slip values in the technical details (A.1.) are measured with a wow-and-flutter meter EMT 420 in accordance with DIN 45507. These values cannot be compared directly with measurements obtained in accordance with different standards.

For this measurements the reference tone from the EMT 420 is recorded. The measurement is then carried out by means of the EMT 420 with the machine running in 'playback'. The vector sum of the record and playback wow-and-flutter will be read on the wow-and-flutter meter.

If the wow and flutter is measured during "record" the physical dimensions such as the circumference of the capstan and the distance between the heads may cause cancellation or doubling of the wow and flutter figures and reliable readings can therefore not be obtained.

As the composition of the wow and flutter can show up faults in the machine, it is recommended to record the measurements on a direct inking oscillograph. The direct comparison of measurements taken from time to time may enable one to recognise developing faults at an early stage.

G.9.1 SLIP MEASUREMENTS

The difference in tape speed between the beginning and the end of a large reel of tape is referred to as "tape slip".

For the measurement of tape slip, the test tone from the wow and flutter meter is recorded at the beginning of a 2400 ft. reel of tape. The two spools are then interchanged. The tape is thus turned over by the interchanging of spools and played backwards. The recorded test tone is now near the core of the left-hand spool. The wow and flutter meter is switched to the tape slip measuring position and the difference in frequency between the two extreme spooling positions is read. One half of this figure is the tape slip in per cent.

THE TAPE SLIP DEPENDS TO A VERY LARGE EXTENT ON THE MECHANICAL CHARACTERISTICS OF THE TAPE USED, IN PARTICULAR ITS THICKNESS.

- The measurement is carried out by means of the azimuth section of the test tape (10 kc/s).
- Ascertain that both channels are giving exactly the same output voltage. If not, the LEVEL controls (G. 4.1) should be re-adjusted.
- The sum level P_s is measured by connecting both playback amplifiers in series in-phase (fig 29).
- If, with the playback outputs connected in series in-phase (measurement of P_s), the signal generator is swept from 1 kc/s to 10 kc/s no minima should be read on the VTVM.

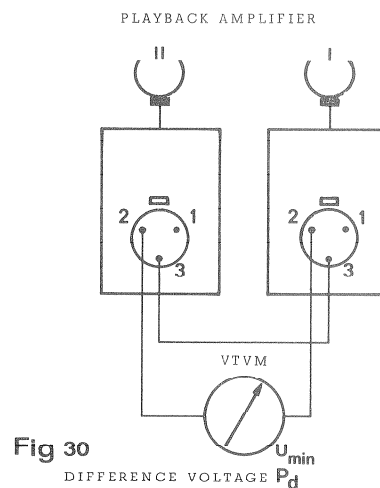
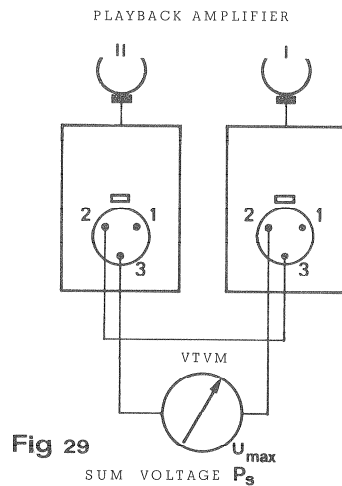

- The difference level P_d is measured by connecting the two outputs in series anti-phase (fig 30).
- In order to determine the phase angle in accordance with fig 31, it is necessary to know the ratio between the sum level and the difference level. This value is easily obtained by remembering the db reading on the VTVM when measuring P_s . Then one channel is reversed and the range switch on the VTVM is turned back until a reading is obtained. In this way the difference of the two levels can be read directly in db.
- In order to obtain a minimum phase angle (less than 10^0) between the two playback channels the playback head should be adjusted by means of the nut C (E. 1.1) for a minimum of P_d .

$$P_{sd} = P_s - P_d \text{ (db)}$$

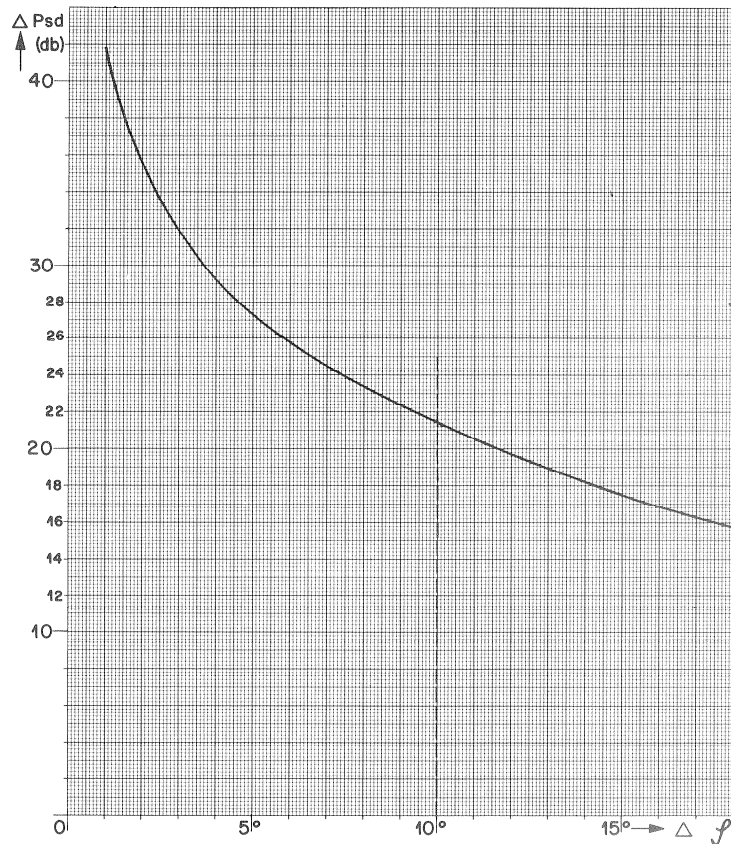

Fig 31

G.10.3 PHASE ANGLE "VIA TAPE"

BEFORE ADJUSTING THE RECORD HEAD, THE PLAYBACK HEAD SHOULD BE ALIGNED IN ACCORDANCE WITH G.10.2. IT IS ADVISABLE TO USE A NEW OR NEARLY NEW TAPE FOR THIS TEST BECAUSE A STRETCHED OR WARPED TAPE WILL GIVE ERRONEOUS READINGS.

- The inputs of the two record amplifiers should be connected in parallel in-phase and fed with a 10 kc/s tone.
- The measurements are taken at the outputs of the two replay amplifiers as described under G.10.2.
- The record head should be adjusted by means of the nut C (E.1.1.) for minimum phase error.

H. Service – Recommendations

Regular servicing is the best insurance for trouble-free operation. Periodic checks of the tape transport mechanism and the amplifiers will generally show up defects before they lead to a breakdown of the unit.

The following instructions should be regarded as recommendations. The intervals between servicings depend to a large extent on how heavily the machine has been used and for the maintenance of the heads the quality of the tape used is of importance.

Cleaning of the heads

The faces of the heads should be inspected after every major session and at least at the end of any working day and cleaned if necessary with a clean piece of linen. Hard deposits are easily removed with tri-chloride.

THE HEAD FACES MUST NOT BE CLEANED WITH HARD OR MAGNETISED OBJECTS.

De-magnetising of heads and tape guides

All the heads and stool parts in the tape path should be de-magnetised approximately once a week.

THE DE-MAGNETISER MUST UNDER NO CIRCUMSTANCES BE BROUGHT CLOSE TO THE LEFT-HAND SPOOLING PLATE TO AVOID ERASING THE MAGNETIC TAPE FOR THE TAPE TENSION CONTROL.

Cleaning of the pinch wheel

If a brown deposit has formed on the pressure roller the roller should be cleaned in the STOP position with ethylene tri-chloride.

DURING THE CLEANING THE PRESSURE ROLLER MUST NOT TOUCH THE CAPSTAN, OTHERWISE THE VOLATILE ETHYLENE TRI-CHLORIDE WILL ATTACK THE OIL RESERVOIR IN THE CAPSTAN BEARING.

Cleaning of the capstan The capstan should also be cleaned carefully and frequently with a clean piece of linen.

NEVER USE HARD OBJECTS.

Testing of the amplifiers See section G.

Testing of the brakes See section D. 2.1.

Testing of the pinch wheel
(pinch wheel pressure) See section E. 6.

Capstan assembly The capstan motor is lubricated for life at manufacture and does not require servicing. The capstan bearings are lubricated for life with " MOBIL DTE Extra Heavy ". If necessary the capstan should be replaced together with the bearing housing. see section E.5

Spooling motors The spooling motors have no lubricating nipples and do not normally require servicing.

Damping pistons The dashpots are permanently lubricated with Molykote-Paste G and do not need any servicing.

IF THEY ARE TO BE RE-LUBRICATED AFTER DISMANTLING ONLY MOLYKOTE G SHOULD BE USED.

(A very small amount should be rubbed into the cylinder walls).

I. Spare Parts List

DECK UNIT

DECK PLATE

DIN Adapter	1.013.029
NAB Adapter	35. 99.0101
Spooling plate (cine center), complete	1.062.390
Guide sleeve	1.736.794-01
Shaft screw	1.736.794-02
Compression spring	1.736.794-03
Bulb holder (mains pilot light)	53. 04.0112
Bulb 16 V, 30 mA (mains pilot light)	51. 02.0136
Tension lever left, complete	1.062.320
Tension lever right, complete	1.062.323
Bashpot, complete	1.062.330
Guide pin	1.062.326-03

Timing indicator window	1.062.310-01
Indicator window (channel indicator)	1.062.310-02
Cover shield (for indicator window)	1.062.310-06

TAPE STABILISER ROLLER, complete (with one ball bearing) 1.062.380

Ball bearing EL 5, P5	41. 02.0203
Roller cover	1.062.101-05
Bearing spacer	1.062.101-06

PRESSURE ROLLER, complete (with one ball bearing) 1.062.385

Ball bearing EL 5, P5	41. 02.0203
Roller cover	1.062.101-05
Bearing spacer	1.062.101-06
Knob for rotary mains switch 7 1/2 - 15 "	1.062.101-15
Knob for rotary mains switch 3.75 - 7 1/2 "	1.062.103-01



Guide roller	1.062.101-03
Covering lid	1.062.101-04
Support frame	1.062.101-02
Spacer 5 mm \varnothing .1 mm thick	1.062.101-07
Spacer 5 mm \varnothing .2 mm thick	1.062.101-08
Spacer 5 mm \varnothing .5 mm thick	1.062.101-09
Spacer 6 mm \varnothing .1 mm thick	1.062.101-10
Spacer 6 mm \varnothing .2 mm thick	1.062.101-11
Spacer 6 mm \varnothing .5 mm thick	1.062.101-12

HEAD BLOCK

Head block mono	1.020.500
Head block two track	1.020.520
Head block cover (standard version)	1.020.514
Head block full track, tranverse pilot tone	1.020.530
Head block full track, neo-pilot tone	1.020.540
Head block cover, pilot tone	1.020.544
Head block stereo, track separation .75 mm (all-metal heads)	1.020.550
Head block half track	1.020.560
Head block stereo, track separation 2 mm	1.020.570
Designation plate	1.020.117-02
Spring rod	1.020.514-02
Tape guide pin complete	1.020.113
Threaded socket	1.020.510-01
Slotted nut (for tape guide pin)	1.020.001-04
Erase head, full-track	1.017.400
Erase head, two-track	1.017.450
Record head, full-track	1.017.410
Record head, two-track	1.017.360
Playback head, full-track	1.017.510
Playback head, two-track	1.017.520
Record head, stereo, track separation .75 mm (all-metal)	1.016.135
Playback head, stereo, track separation .75 mm (all-metal)	1.016.145
Erase head, stereo	1.016.150
Record head, half-track	1.017.470
Playback head, half-track	1.017.480

Erase head, half-track	1.017.460
Transverse pilot tone head	1.017.910
Neo pilot tone head	1.017.920
Adjusting plate (for record and erase head)	1.020.127
Adjusting plate (for playback head)	1.020.506
Adjusting plate (for pilot tone head)	1.020.534
Swivel plate	1.736.226-07
Slotted nut (for record and erase head)	1.736.226-02
Slotted nut (for threaded pin)	1.736.226-04
Slotted nut (for playback head)	1.020.001-02
Threaded pin	1.020.001-05
Spring washer	37.01.0101
Nut M2, 6	22.01.8026
Compensating plate, complete	1.020.512
Screening plate	1.020.508-01
Screening can complete (for playback head)	1.020.504
Screening can (for record head)	1.736.226-06
Amphenol connector, 24-pole	54.02.0133

C A P S T A N D E C K

PIVOT ARM, complete	1.062.130
Guide piece, riveted	1.062.131
Pivot lever	1.062.130-01
Guide pin	1.062.130-02
Editing solenoid	1.014.350
Pressure roller solenoid	1.014.500
Torsion spring	1.062.110-02
Return spring	1.062.110-03
Solenoid cut-out switch, complete	1.062.120
Assembly plate, complete (with bulb holder for pilot lamps)	1.062.186

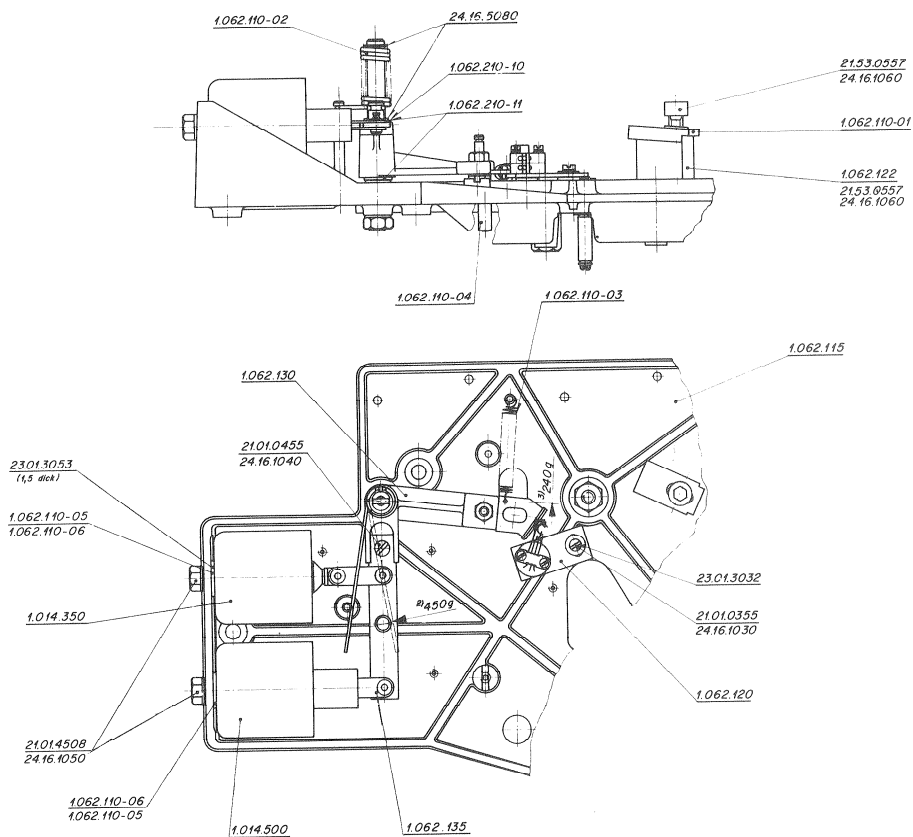

Bulb 36 V, 50 mA (pilot lamp)	51. 02.0104
Metal cover, complete (for pilot lamps)	1.062.187
Dashpot, complete (for pressure roller arm)	1.062.190
Guide ring	1.062.105-06

If the dashpot 1.062.190 with cupped piston (round piston rod) is replaced, two guide rings should be fitted.

PRESSURE ROLLER ARM, complete (with two ball bearings)	1.062.148
STABILISER ROLLER ARM, complete (with two ball bearings)	1.062.142
Pre-tensioning spring complete (with bearing pin)	1.062.145
Bearing shaft (for pre-tensioning spring)	1.062.140-01
Guide ring (for stabiliser roller arm)	1.062.142-05
Benzing securing clip 2.3 mm \varnothing	24. 16.3023

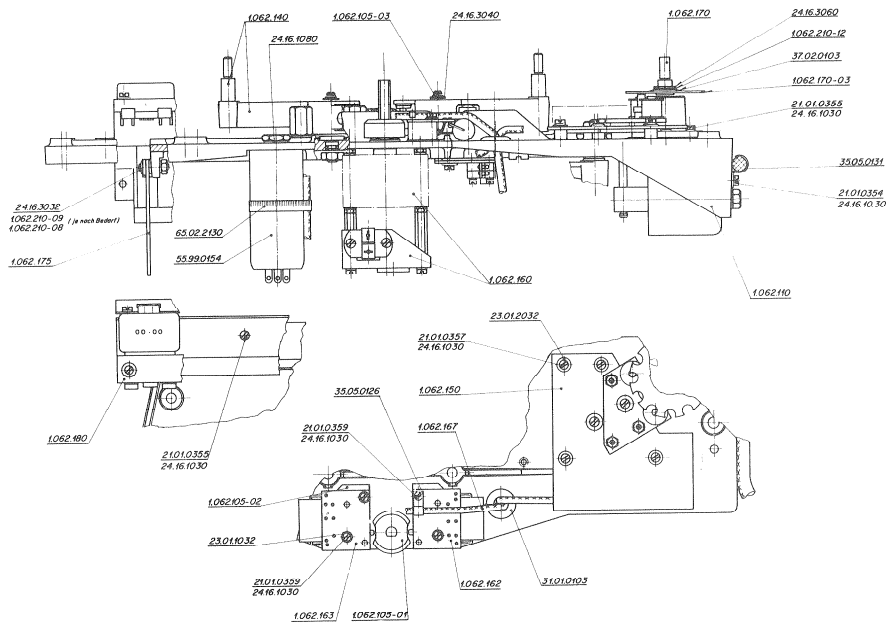

Seeger internal ring 20 mm \varnothing	24. 16.4190
Spring washer 'K'	37. 02.0104
Ball bearing EL 6 Z pressure roller & stabiliser roller arm	41. 02.1104
Spacer 4 mm \varnothing .2 mm thick	1.062.210-09
Benzing securing clip 3.2 \varnothing	24. 16.3032
END-OF-TAPE SWITCH ASSEMBLY, complete	1.062.150
Base plate, complete	1.062.151
End-of-tape switch coil, complete	1.062.152
End-of-tape switch board, assembled	1.062.155
Transistor BSY 54	50. 03.0404
Diode 1 S 130	50. 04.0110
Transistor mounting	50. 03.9901
Base plate	1.062.150-01
Plastic foam washer	1.062.150-02
Benzing securing clip 3.2 mm \varnothing	24. 16.3032
Spring washer	37. 01.0101

OPERATING SWITCH, complete	1.062.160
Operating switch	1.062.160-01
Mounting bracket	1.062.160-02
Threaded pin	27. 23.2115
Miniature connector 6-pole	54. 02.0214
Chassis socket 2-pole	54. 99.0108
Switch-cams	1.062.105-01
Insulating plate	1.062.105-02
MP condenser (Capstan motor phase shift) $2\mu\text{F} + .5\mu\text{F}$	59. 99.0154
SUPPRESSOR PLATE, left complete (with micro-switch)	1.062.162
SUPPRESSOR PLATE, right complete (with micro-switch)	1.062.163
Suppressor plate riveted	1.062.164
Miniature plug, 4-pole (for mains cable)	54. 02.0202
MP condenser $.05\ \mu\text{F}$, 250 V	59. 99.0156
Micro switch	55. 01.0122
GUIDE ROLLER BEARING, complete	1.062.170
Bearing housing	1.062.170-01
Control shaft	1.062.170-02
Magnet disc	1.062.170-03
Spacer	1.062.170-04
Benzing securing clip 4 mm \emptyset	24. 16.3040
Seeger interal ring	24. 16.4160
Ball bearing ELF Z	41. 02.1103
Spring washer 'K'	37. 02.0103
Spacer 8 mm \emptyset , 1 mm thick	1.062.210-12
Benzing securing clip 6 mm \emptyset	24. 16.3060
LEVER, complete (timing indicator zero re-set)	1.062.175
PUSH BUTTON UNIT, complete	1.062.180
Push button panel, assembled	1.062.181
Diode 1 S 130	50. 04.0110

Relay socket Tstv 24 e	56. 01.0125
Relay socket Tstv 24 f	56. 01.0127
Relay Siemens 154 d - 93e - 65421	56. 01.0101
Relay Siemens 154 c - 93d - 65422	56. 01.0111
Relay retaining clip Tstv 24 T8	56. 01.0122
Relay retaining clip Tstv 24 T9	56. 01.0124
Potentiometer 2.5 k-ohm ceramic	58. 20.2252
Push button " Fast Rewind "	1.062.180-10
Push button " Fast Forward "	1.062.180-11
Push button " Playback "	1.062.180-12
Push button " Stop "	1.062.180-13
Push button " Erase stereo " (wide button)	1.062.180-14
Push button " Erase I "	1.062.180-15
Push button " Erase II "	1.062.180-16
Push button " Editing "	1.062.180-17
Push button " Trimming Indicator "	1.062.180-18
Switch contact	55. 02.0101
Push button unit chassis	1.062.180-01
Guide rail	1.062.180-02
Slider	1.062.180-03
Shim	1.062.180-04
Insulating strip, upper	1.062.180-05
Insulating strip, lower	1.062.180-06
Spacer	1.062.180-07
Leaf spring, weak	1.062.180-08
Leaf spring, strong	1.062.180-09
Threaded rail	1.062.180-20
Clamping rail	1.062.180-21
Cover plate	1.062.180-23
Push button panel, riveted	1.062.182

TIMING INDICATOR

1.061.001

Drive shaft	1.061.001-01
Sleeve spacer 32 long	1.061.001-03
Sleeve spacer 14 long	1.061.001-04
Sleeve spacer 2.8 long	1.062.001-05
Sleeve spacer 4 long	1.062.001-06

Worm	1.061.001-02
Shaft	1.061.001-07
Compression spring	1.061.001-11
Shaft bearing, left, complete	1.061.106
Shaft bearing, right, complete	1.061.105
Special nut	1.061.001-14
Extension spring	1.061.001-15
Extension spring (additional spring)	1.061.001-16
Threaded pin M 4 x 30 (stop pin)	21. 99.0108
Number roller unit (with worm wheel)	1.061.110
Minute wheel, complete	1.061.120
Worm wheel	1.061.110-03
Spacer 6 mm \varnothing .2 thick	1.062.101-11
Zero reset unit (without roller)	1.061.130
Roller (for zero reset)	1.061.001-08
Roller	1.061.001-09
Disc (for zero reset)	1.061.130-01
Setting wheel	1.061.100-03
Plate	1.061.100-04
Leaf spring	1.061.100-05
Ball 5.56 mm diameter (7/32")	41. 01.0105
Dashpot	1.061.200
Ball bearing EL 6 ZZ	41. 02.0104
Spring washer 'K'	37. 02.0204

S P O O L I N G D E C K

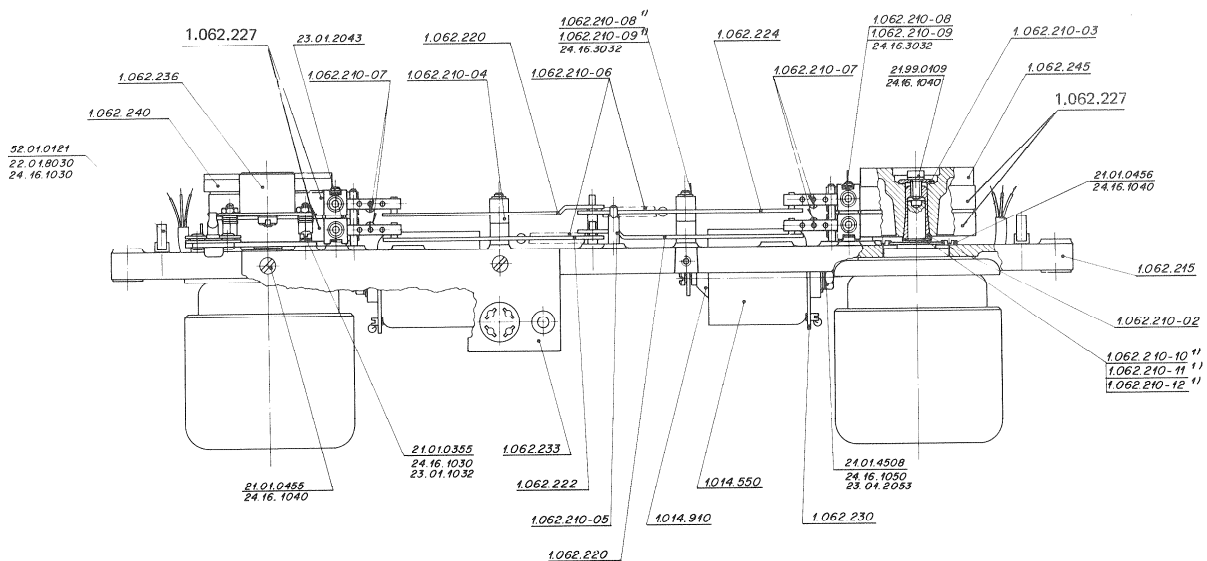

Soldering tag on ceramic insulator		52. 01.0121
Brake lever, complete		1.062.220
Brake lever, lower, complete		1.062.222
Brake lever, upper, complete		1.062.224
Compensating ring		1.062.210-04
Brake band, left, complete	} Machine No. 100 - 199	1.062.226
Brake band, right, complete		1.062.228
As replacement for 1.062.226 + 1.062.228 part No. 1.062.227 should be used.		
Brake band complete	as from Machine No. 200	1.062.227
Spacer 4 mm \varnothing .1 thick		1.062.210-08
Spacer 4 mm \varnothing .2 thick		1.062.210-09
Spacer 8 mm \varnothing .2 thick		1.062.210-10
Spacer 8 mm \varnothing .5 thick		1.062.210-11
Spacer 8 mm \varnothing 1 thick		1.062.210-12
Tag board, assembled		1.062.230
Diode 1 S 130		50. 04.0110
Miniature connector 4 - pole		54. 02.0212
Amphenol plug, 36 - pole		54. 02.0134
Special connector, 36 - pole		1.012.001-09
Plug housing, left		1.012.001-01
Plug housing, right		1.012.001-02
Plug nut		1.012.001-05
Relief slider, complete		1.012.101
Tensioning bracket		1.012.001-08
Compensating sleeve		1.012.001-06
Brake solenoid		1.014.550
Plunger complete (for brake solenoid)		1.014.910
Spooling motor until No. 1200		1.062.210-01
Spooling motor from No. 1201		1.062.210-13
Collett		1.062.210-02
Collette disc		1.062.210-03
Damping tube		1.062.210-05
Return spring		1.062.210-06
Brake tension spring		1.062.210-07
C O N T R O L H E A D A S S E M B L Y		1.062.236
Tension control head		1.017.900
Base plate		1.062.236-01
Adjusting plate		1.062.236-02

Threaded bolt	1.062.236-03
Screening can	1.062.236-04
Slotted nut special (nylon)	1.020.001-02
Spring washer	37. 01.0101
Socket	54. 02.0291
Insulating disc	54. 02.0292
Tape tension control, complete	1.062.240
Brake roller, complete	1.062.245
TRANSFORMER ASSEMBLY, complete	1.062.270
Mains transformer, wired	1.062.275
Transformer mounting frame	1.062.270-02
Mounting pin	1.062.270-03
Threaded bolt	1.062.270-04
Shimming	1.062.270-05
Spacing can	1.062.270-06
Tag strip	1.062.275-01
POWER SUPPLY, complete	1.062.280
Magnetic amplifier I, assembled	1.062.283
Magnetic amplifier II, assembled	1.062.286
Fuse panel, assembled	1.062.295
Fuse holder	53. 03.0141
Diode BYY 33	50. 04.0502
Diode 1 N 4721	50. 04.0507
Support	1.062.280-02
Threaded pin M 4 / M 3	1.062.280-03
Threaded pin M 3	1.062.280-04
Electrolytic condenser 2500 μ F, 35 V	59. 13.3252
Insulating washer	59. 20.0107
Insulating disc	59. 20.0108
Elapsed time indicator 50 c/s (with mounting)	73. 01.0103
Elapsed time indicator 60 c/s (with mounting)	73. 01.0104

RELAY HOLDER, assembled (without relays)		1.062.260
Relay panel, assembled (without relays)		1.062.265
Relay holder		1.092.132
Intermediate piece		1.092.003-01
Plug-in relay 2 - pole (Studer)		1.092.002
Plug-in relay 1 - pole (Studer)		1.093.002
MP condenser (phase shift for spooling motor) 5 μ F 500 V=		59. 99.0149
MP condenser (phase shift for spooling motor) 2 μ F 380 V ~		59. 99.0455
Voltage selector (for fuses 5 x 20)		53. 03.0123
Voltage selector (for fuses 6 x 30)		53. 03.0125
Fuse element (for fuses 5 x 20)		53. 03.0113
Fuse element (for fuses 6 x 30)		53. 03.0112
Chassis connector, 11 - pole		54. 02.0232
Remote control dummy plug		1.062.251
Equipment mains plug		54. 04.0102
CAPSTAN ASSEMBLY	50 c/s 7 1/2 " - 15 "	1.062.350
Capstan assembly	60 c/s 7 1/2 " - 15 "	1.062.360
Capstan assembly	50 c/s 3.75 " - 7 1/2 "	1.062.370
Coupling piece, complete (version which is screwed onto drive shaft)		1.062.355
Coupling piece, (version which is pushed onto drive shaft)		1.736.125-02
Plastic cover		1.736.128-06
Securing disc (rubber, for fixing inertia wheel)		1.736.128-07
Capstan motor complete, 50 c/s		1.062.358
Capstan motor complete, 60 c/s		1.062.368
Centering pin		1.062.350-01
Capstan bearing with capstan 50 c/s 7 1/2" - 15"		1.062.353
Capstan bearing with capstan 60 c/s 7 1/2" - 15"		1.062.363
Capstan bearing with capstan 50 c/s 3.75 " - 7 1/2 "		1.062.373
Centering Disc		1.062.350-06
Ball bearing		41. 99.0101
AMPLIFIER FRAME, complete		1.062.400
Set of parts " Pilot tone " for amplifier frame		1.062.402
Amplifier frame, complete, pilot tone		1.062.401
Plug, Continental - M, (for playback amplifier)		54. 06.1811

Plug, Continental - N	(for record amplifier)	54. 06.1812
Plug, Continental	(for tension control and stabiliser)	54. 06.1800
Plug, Continental	(for pilot tone amplifier)	54. 06.1800
Polarizing key	(for pilot tone amplifier)	54. 06.4425
36 - pole connector , special		1.012.001-09
Plug housing, left		1.012.001-01
Plug housing, right		1.012.001-02
Plug nut		1.012.001-05
Relief slider, complete		1.012.101
Tension control head cable (with plug)		1.062.435
Amphenol plug, 24-pole		54. 02.0132

PLUG - IN AMPLIFIER

(with record and replay amplifier, without equalisation) 1.062.700

Metal guide		1.062.700-01
Assembly strip		1.062.700-03
Spacing pin		1.062.500-04
Record equaliser CCIR, 35 + 70 μ s, 7 1/2 " - 15 "		1.062.450
Playback equaliser CCIR, 35 + 70 μ s, full - track / half - track 7 1/2 " - 15 "		1.062.460
Playback equaliser CCIR, 35 + 70 μ s / two - track 7 1/2 " - 15 "		1.062.465
Record equaliser CCIR, 70 + 90 μ s, full - track 3.75 " - 7 1/2 "		1.062.454
Record equaliser CCIR 70 + 90 μ s, half - track / two-track / Stereo 3.75 " - 7 1/2 "		1.062.455
Record equaliser NAB, 50 + 50 μ s 7 1/2 " - 15 "		1.062.470
Playback equaliser CCIR, 70 + 90 μ s 3.75 " - 7 1/2 "		1.062.464
Playback equaliser CCIR, 70 + 90 μ s, stereo .75 mm track separation 7 1/2 " - 15 "		1.062.466
Playback equaliser NAB 50 + 50 μ s, full - track 7 1/2 " - 15 "		1.062.475
Playback equaliser NAB 50 + 50 μ s, two - track 7 1/2 " - 15 "		1.062.480
Screening hood		1.062.450-02
Equaliser plug, assembled		1.062.452
Designation plate		1.062.750-01
Slider, record		1.062.750-05
Slider, playback		1.062.750-04
Handle		1.062.550-07
Handle holder		1.062.550-06
Slider spring		1.062.650-03

Camloc locking cone	33. 02.0118
Camloc retaining disc	33. 02.0180
Chassis mounting plug, 3 - pole (Cannon)	54. 02.0282
Chassis connector, 3 - pole (Cannon)	54. 02.0283
Plug , 3 - pole (Cannon)	54. 02.0280
Connector, 3 - pole (Cannon)	54. 02.0281
RECORD PANEL, assembled	1.062.770
Screening (record), complete	1.062.777
Oscillator coil	1.062.780
HF - choke	1.062.786
Coil for tuned rejector circuit	1.062.740
Input transformer, record	1.062.770-03
Diode 1 S 130	50. 04.0110
Transistor ASY 27	50. 03.0104
Transistor ASY 80	50. 03.0109
Transistor BSY 51	50. 03.0401
Transistor BSY 52	50. 03.0402
Transistor BSY 53	50. 03.0403
Transistor cooling fin	1.010.001-50
Transistor mounting	50. 03.9901
Valve holder, 7 - pin	53. 01.0112
Relay 162b 119e	56. 01.0106
Relay socket Tstv 24 f	56. 01.0127
Retaining clip Tstv 24 T9	56. 01.0124
Relay 162a 119d	56. 01.0115
Relay socket Tstv 24e	56. 01.0125
Retaining clip Tstv 24 T8	56. 01.0122
Potentiometer 10 K Ω , lin, short shaft	58. 20.6103
Potentiometer 10 K Ω , lin, long shaft	58. 20.8103
Potentiometer 100 K Ω , lin, short shaft	58. 20.6104
Potentiometer 100 K Ω , lin, long shaft	58. 20.8104
Potentiometer 100 K Ω , lin, short shaft	58. 20.6104
Potentiometer 100 K Ω , lin, long shaft	58. 20.8104

PLAYBACK PANEL, assembled	1.062.720
Screening (playback) complete	1.062.727
Line transformer	1.062.730
Coil for tuned rejector circuit	1.062.740
Diode 1 S 130	50. 04.0110
Diode 1 N 914	50. 04.0102
Transistor ASY 27	50. 03.0104
Transistor BCY 27	50. 03.0303
Transistor BSY 51	50. 03.0401
Transistor BSY 54	50. 03.0404
Transistor mounting	50. 03.9901
Transistor cooling fin	1.010.001-50
Miniature valve holder, 7 - pole	53. 01.0112
Relay 162b 119e	56. 01.0106
Relay socket Tstv 24f	56. 01.0127
Retaining clip Tstv 24 T9	56. 01.0124
Pre-set potentiometer 2.5 k lin	58. 20.4252
Potentiometer 2 k lin	58. 20.6202
Potentiometer 10 k lin	58. 20.6103

STABILISER PLUG - IN UNIT

Metal guide upper	1.062.500-01
Metal guide, lower	1.062.500-02
Assembly strip	1.062.500-03
Spacing pin	1.062.500-04
Designation plate	1.062.550-01
Handle holder	1.062.550-06
Handle	1.062.550-07
Camloc locking cone	33. 02.0118
Camloc retaining disc	33. 02.0180

STABILISER PANEL, assembled

Diode BYY 31	50. 04.0501
Zener diode ZF 7.5	50. 04.1103
Transistor ASZ 18 (on heat sink)	50. 03.0201

Assembly fittings therefore	50. 03.9902
Transistor ASY 80	50. 03.0109
Transistor ASY 51	50. 03.0401
Transistor mounting	50. 03.9901
Pre-set potentiometer 250 ohms	58. 20.2251

A

TENSION CONTROL PLUG-IN UNIT 7 1/2 " - 15 "
 or 3.75 " - 7 1/2 " 1.062.600

The correct replacement is 1.062.601 for 7 1/2 " - 15 "
 machines or 1.062.603 for 3.75 " - 7 1/2 " machines.

Metal guide	1.062.600-01
Assembly strip	1.062.500-03
Spacing pin	1.062.500-04
Front panel complete	1.062.650
Designation plate	1.062.650-01
Slider spring	1.062.650-03
Slider tension control	1.062.650-04
Handle holder	1.062.550-06
Handle	1.062.550-07
Camloc locking cone	33. 02.0118
Camloc retaining disc	33. 02.0180

TENSION CONTROL PANEL assembled 7 1/2 " - 15 "
 or 3.75 " - 7 1/2 " 1.062.620

1.062.620 should not be used as replacement. The complete
 plug-in unit 1.062.600 should be replaced with 1.062.601
 or 1.062.603

Diode 1 S 130	50. 04.0110
Zener Diode ZF 3.3	50. 04.1107
Transistor ASY 27	50. 03.0104
Transistor ASY 80	50. 03.0109
Transistor BSY 51	50. 03.0401
Transistor mounting	50. 03.9901
Relay 154c - 93d	56. 01.0111
Relay socket Trsv 24e	56. 01.0125

Retaining clip Trsv 24 T 19	56. 01.0126
Potentiometer 500 Ω lin.	58. 20.6501
Tension control transformer	1.062.694

B

TENSION CONTROL PLUG-IN UNIT 7 1/2 " - 15 "	1.062.601
TENSION CONTROL PLUG-IN UNIT 3.75" - 7 1/2 "	1.062.603
Metal guide	1.062.600-01
Assembly strip	1.062.500-03
Spacing pin	1.062.500-04
Front panel, complete	1.062.652
Designation plate	1.062.652-01
Slider spring	1.062.650-03
Slider, tension control	1.062.651-03
Handle holder	1.062.550-06
Handle	1.062.550-07
Camloc locking cone	33. 02.0118
Camloc retaining disc	33. 02.0180
TENSION CONTROL PANEL assembled 7 1/2 " - 15 "	1.062.621
TENSION CONTROL PANEL assembled 3.75 " - 7 1/2 "	1.062.623

1.062.621 and 1.062.623 are not suitable as replacements
in the plug-in unit 1.062.600

Diode 1 S 130	50. 04.0110
Diode 1 N 914	50. 04.0102
Zener diode BZY 56	50. 04.1112
Transistor 2 N 3906	50. 03.0304
Transistor BC 109c	50. 03.0407
Relay PZ - A 2610	56. 04.0121
Potentiometer 2 k Ω lin	58. 11.7202
Potentiometer 500 Ω lin	58. 11.7501
Potentiometer 5 k Ω lin	58. 20.4502

C

PILOT TONE AND TENSION CONTROL PLUG-IN UNIT 7 1/2 " - 15 "	1.062.601
PILOT TONE AND TENSION CONTROL PLUG-IN UNIT 3.75 " - 7 1/2 "	1.062.604

Metal guide	1.062.600-01
Assembly strip	1.062.500-03
Spacing pin	1.062.500-04
Front panel, complete	1.062.651
Designation plate	1.062.651-01
Slider spring	1.062.650-03
Slider, tension control	1.062.651-03
Handle holder	1.062.550-06
Handle	1.062.550-07
Camloc locking cone	33. 02.0118
Camloc retaining disc	33. 02.0180
Chassis connector, 5 - pole (Cannon)	54. 02.0285
Plug, 5 - pole (Cannon)	50. 02.0284

PILOT TONE PANEL assembled	1.062.670
----------------------------	-----------

Zener diode ZF 10	50. 04.1114
Transistor BC 179	50. 03.0305
Transistor BC 109c	50. 03.0407
Transistor BC 107	50. 03.0408
Potentiometer 100 Ω lin	58. 11.7101
Potentiometer 100 K Ω lin	58. 20.2104
Potentiometer 25 K Ω lin	58. 20.2253
Input transformer STR 145 BV 38752	62. 01.0102
HF - transformer winding	1.062.690
Shell core P 18/11	61. 01.0101
Z - screw, nylon M3 x 15	21. 99.0115

CARRYING CASE 062	1.062.950
-------------------	-----------

Lid of case, complete	1.062.959
Lower part of case, complete	1.062.958
Back panel cover, complete (with metal re-inforcements)	1.062.961
Handle, complete	1.062.962

Connecting bracket	1.062.950-08
Corner piece	33. 06.0101
Corner piece, special	1.062.950-09
Felt disc (for back panel)	1.062.950-24
Locking hook (for lower part of case)	33. 01.0100
Lock (for lid of case)	33. 01.0101
Ball catch	33. 05.0101
Clip part	33. 05.0106
Solid disc (for securing the machine in the case)	1.010.005-23
LS screw, special M5 x 20 (for securing the machine in the case)	21. 99.0111

Extender board stabiliser, complete	1.062.991
Extender board tension control, complete	1.062.992
Extender board pilot tone, complete	1.062.993
Extender board playback, complete	1.062.994
Extender board record, complete	1.062.995

K. Circuit Diagrams

Schaltbilder

①	LAUFWERKEINHEIT bis Nr. 1200 TAPE TRANSPORT UNIT until No. 1200	1.062.101 - 104
①A	LAUFWERKEINHEIT ab Nr. 1201 TAPE TRANSPORT UNIT from No. 1201	1.062.101 - 104
②	DRUCKTASTEN-CHASSIS PUSH-BUTTON BOARD	6.062.180
③	LAUFWERK-CHASSIS CAPSTAN DECK Endschalter SAFETY SWITCH BOARD	6.062.105 1.062.155
④	MOTOREN-CHASSIS BL.1 bis Nr. 1200 SPOOLING DECK until No. 1200	6.062.200 BL.1
④A	MOTOREN-CHASSIS BL.1 ab Nr. 1201 SPOOLING DECK from No. 1201	6.062.200 BL.1
⑤	MOTOREN-CHASSIS BL.2 SPOOLING DECK Sicherungsplatte FUSE BOARD	6.062.200 BL.2 1.062.295
⑥	RÜCKWAND REAR PANEL Relaisplatte RELAY BOARD	6.062.250 1.062.265
⑦	VERSTÄRKERKORB (PILOT) WIRING CARD BOX (PILOT)	6.062.401 (400)
⑧	ANSCHLUSSTECKER VOLLSPUR/HALBSPUR HEAD ASSY. CONNECTOR FULL-TRACK/HALF-TRACK KOPFTRÄGER VOLLSPUR HEAD ASSY. FULL-TRACK TRANSVERSAL-PILOT NEOPILOT	1.020.508/568 6.020.500 6.020.530 6.020.540
⑨	ANSCHLUSSTECKER ZWEISPUR HEAD ASSY. CONNECTOR DUAL-TRACK KOPFTRÄGER ZWEISPUR HEAD ASSY. DUAL-TRACK	1.020.518 6.020.520
⑩	ANSCHLUSSTECKER STEREO HEAD ASSY. CONNECTOR KOPFTRÄGER STEREO 2 mm HEAD ASSY. STEREO 0,75 mm	1.020.558 6.020.570 6.020.550
⑪	STABILISATOR POWER SUPPLY	7.062.520
⑫		1.062.520
⑬	BREMSSTEUERUNG TAPE TENSION CONTROL	7.062.620
⑭		1.062.620
⑮	BREMSSTEUERUNG TAPE TENSION CONTROL	7.062.621
⑯		1.062.621
⑰	PILOTTON-VERSTÄRKER PILOT AMPLIFIER	7.062.670
⑱		1.062.670
⑲	WIEDERGABEVERSTÄRKER PLAYBACK AMPLIFIER	7.062.720
⑳		1.062.720
㉑	WIEDERGABE-ENTZERRUNGEN PLAYBACK EQUALIZATIONS	
㉒	AUFNAHME-VERSTÄRKER RECORD AMPLIFIER	7.062.770
㉓		1.062.770
㉔	AUFNAHME-ENTZERRUNGEN RECORD EQUALIZATIONS	

TABELLE DER RELAIS- UND MAGNETFUNKTIONEN
 TABLE SHOWING THE FUNCTIONING OF THE RELAYS AND SOLENOIDS

x Relais oder Magnet unter Strom, bzw. Micro-Switch geschlossen.
 Relay or solenoid energised or micro switch "made"

(x) Magnet kurzzeitig unter Strom.
 Solenoid temporarily energised

Relais Relay	19 cm/s 7,5 in/s	38 cm/s 15 in/s	← ← ←	→ → →	Play	Aufn. I Rec. I	Aufn. II Rec. II	C	← ← ←	→ → →	Reglerstart Remotestart	in Baugruppe in assembly	Schema Diagram
RLB	x											Bremst. Tape Tens- Control	7.062.620
RLW	x											Wdg. - KI Pb. - Ch I	7.062.720
RLW	x											Wdg. - KII Pb. - Ch II	
RLA	x											Aufn. - KI Rec. - Ch I	7.062.770
RLA	x											Aufn. - KII Rec. - Ch II	
RLAO	x											Aufn. - KI Rec. - Ch I	7.062.770
RLAO	x											Aufn. - KII Rec. - Ch II	
RA						x						Aufn. - KI Rec. - Ch I	7.062.101
RA							x					Aufn. - KII Rec. - Ch II	
SR			x						x			Relaisträger Relay Panel 1.062.260	7.062.101
SV				x	x	x	x			x	x		
SS	x	x	x	x				x	x	x	x		
SB					x	x	x				x		
RS			x	x	x	x	x		x	x	x		
RR			x						x			Drucktastenpl. Push Button 1.062.180	7.062.101
RV				x							x		
RAM	x	x	x	x				x	x	x			
RB					x	x	x						
RBh					x	x	x						
RA1						x						7.062.101	
RA2							x						
RC								x	x	x			
RF											x	7.062.101	
MA					x	x	x				x		
MAC					(x)	(x)	(x)	x	x	x	(x)		
MB			x	x	x	x	x		x	x	x	Motoren - Ch. Spooling - Deck 1.062.200	7.062.101
MBC			x	x	x	x	x	x	x	x	x		
MSA	x	x	x	x				x	x	x		7.062.101	
MSM					x	x	x	x	x	x	x		

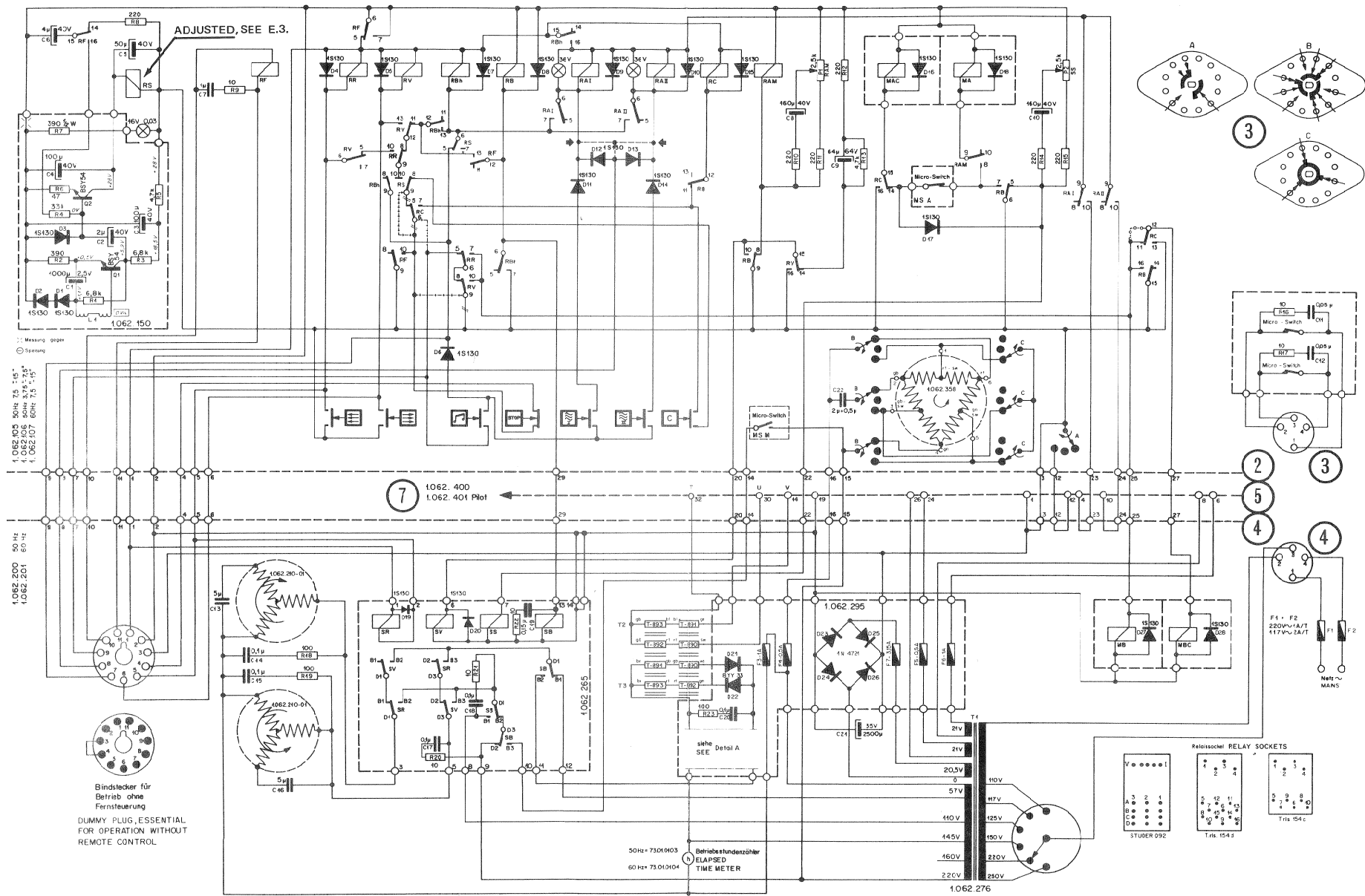

STUDER A62

- 1.062.101 = 50 Hz, 7,5"-15"
- 1.062.102 = 60 Hz, 7,5"-15"
- 1.062.103 = 50 Hz, 3,75-7,5"
- 1.062.104 = 50 Hz, 7,5"-15" (Pilot)

Schalterstellung: 15" and STOP SWITCHES SHOWN IN POSITION 15" AND STOP

Gültig ab Maschinen Nr. 501
VALID FROM SERIAL No. 501

LAUFWERKEINHEIT TAPE TRANSPORT UNIT



--- verbunden bei Stereo-Maschinen (durchgehende Löschtaaste) und für Aufnahme-anzeige in Fernstauertaste.
CONNECTED IN MACHINES WITH ONLY ONE RECORD BUTTON. PERMITS RECORD INDICATION IN REMOTE CONTROL.

---/--- getrennt = kein Rangieren mehr. (C-Stellung fällt heraus bei Be-tätigung der Umspultasten)
CONNECTED, / DISCONNECTED: NO MORE FAST TAPE TRANSPORT IN C-POSITION. (WINDING BUTTONS BRING IDLERS INTO STOP POSITION.)

---o--- verbunden = C-Bremsen gelöst
CONNECTED: RELEASES BOTH MECHANICAL BRAKES IN C-POSITION.

Relaissockel RELAY SOCKETS

STUDER 092	Tris 154 J																																
<table border="1"> <tr><td>1</td><td>2</td><td>3</td><td>4</td></tr> <tr><td>5</td><td>6</td><td>7</td><td>8</td></tr> <tr><td>9</td><td>10</td><td>11</td><td>12</td></tr> <tr><td>13</td><td>14</td><td>15</td><td>16</td></tr> </table>	1	2	3	4	5	6	7	8	9	10	11	12	13	14	15	16	<table border="1"> <tr><td>1</td><td>2</td><td>3</td><td>4</td></tr> <tr><td>5</td><td>6</td><td>7</td><td>8</td></tr> <tr><td>9</td><td>10</td><td>11</td><td>12</td></tr> <tr><td>13</td><td>14</td><td>15</td><td>16</td></tr> </table>	1	2	3	4	5	6	7	8	9	10	11	12	13	14	15	16
1	2	3	4																														
5	6	7	8																														
9	10	11	12																														
13	14	15	16																														
1	2	3	4																														
5	6	7	8																														
9	10	11	12																														
13	14	15	16																														

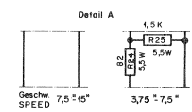

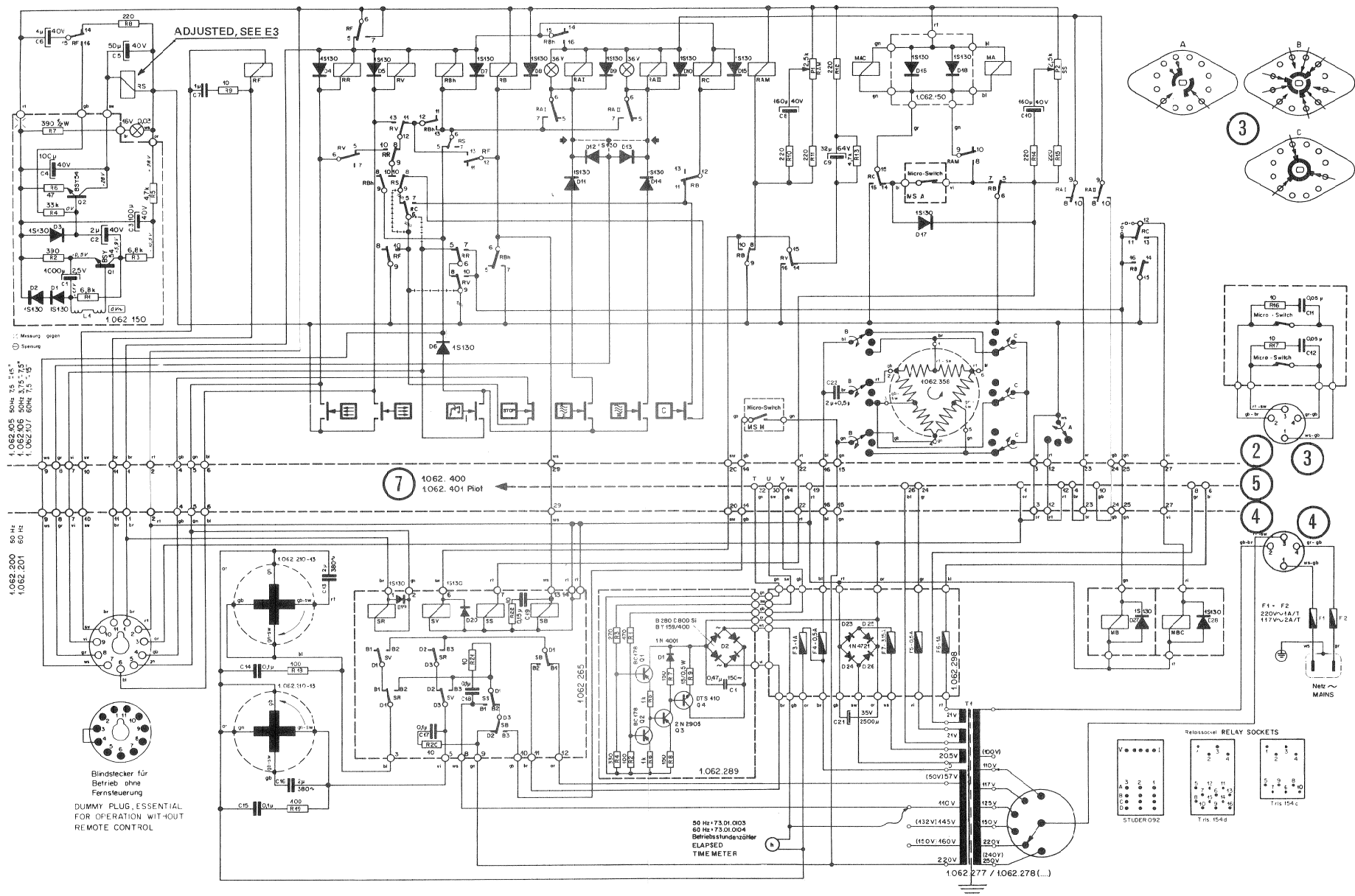

STUDER A 62

- 1.062.101 = 50 Hz, 7,5" - 15"
- 1.062.102 = 60 Hz, 7,5" - 15"
- 1.062.103 = 50 Hz, 3,75" - 7,5"
- 1.062.104 = 50 Hz, 7,5" - 15" (Pilot)

Schalterstellung: 15" und STOP
 SWITCHES SHOWN IN POSITION 15" AND STOP
 Gültig für Maschinen Nr. 1201 - 1750
 VALID FOR SERIAL No. 1201 - 1750

**LAUFWERKEINHEIT
 TAPE TRANSPORT UNIT**



- Nicht verbunden bei Zweispur-Maschinen.
 NOT CONNECTED IN TWO-TRACK MACHINES.
- verbunden, // getrennt = kein Rangieren mehr (C-Stellung fällt: heraus bei Be-
 tätigung der Umspultasten.
 CONNECTED, // DISCONNECTED: NO MORE FAST TAPE TRANSPORT IN
 C-POSITION (WINDING BUTTONS BRING IDLERS INTO STOP POSITION)
- verbunden = C - Bremsen gelöst.
 CONNECTED: RELEASES BOTH MECHANICAL BRAKES IN C-POSITION.

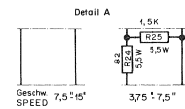

TO 6.062.105 ③

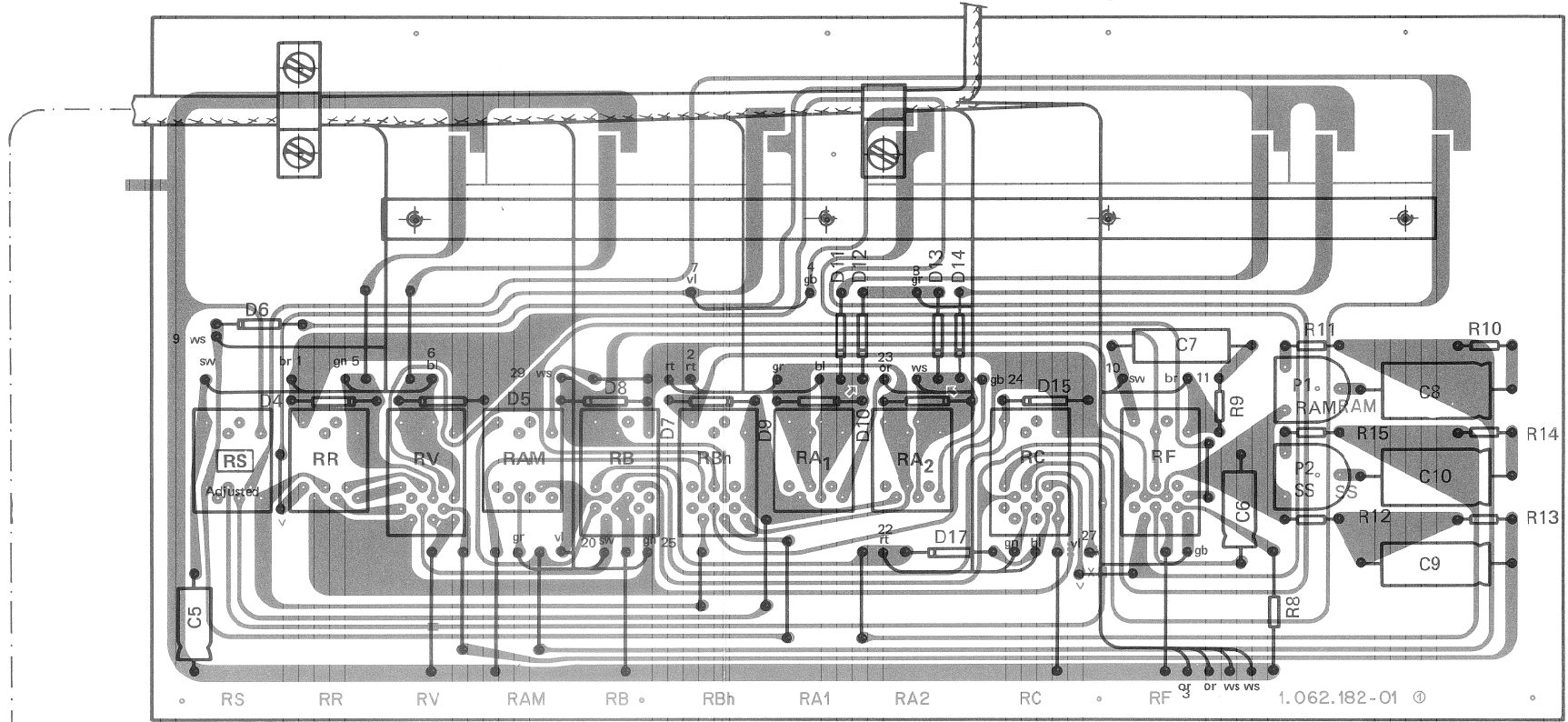

Auf Kaschierung gesehen.
PRINTED SIDE

TO 6.062.200 ④

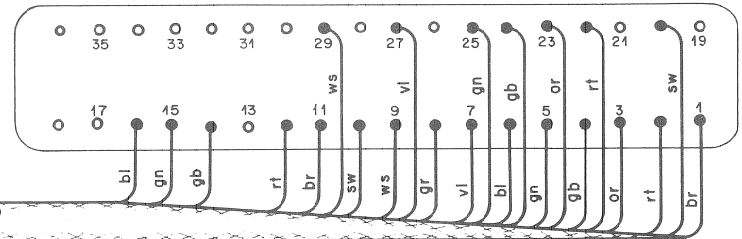

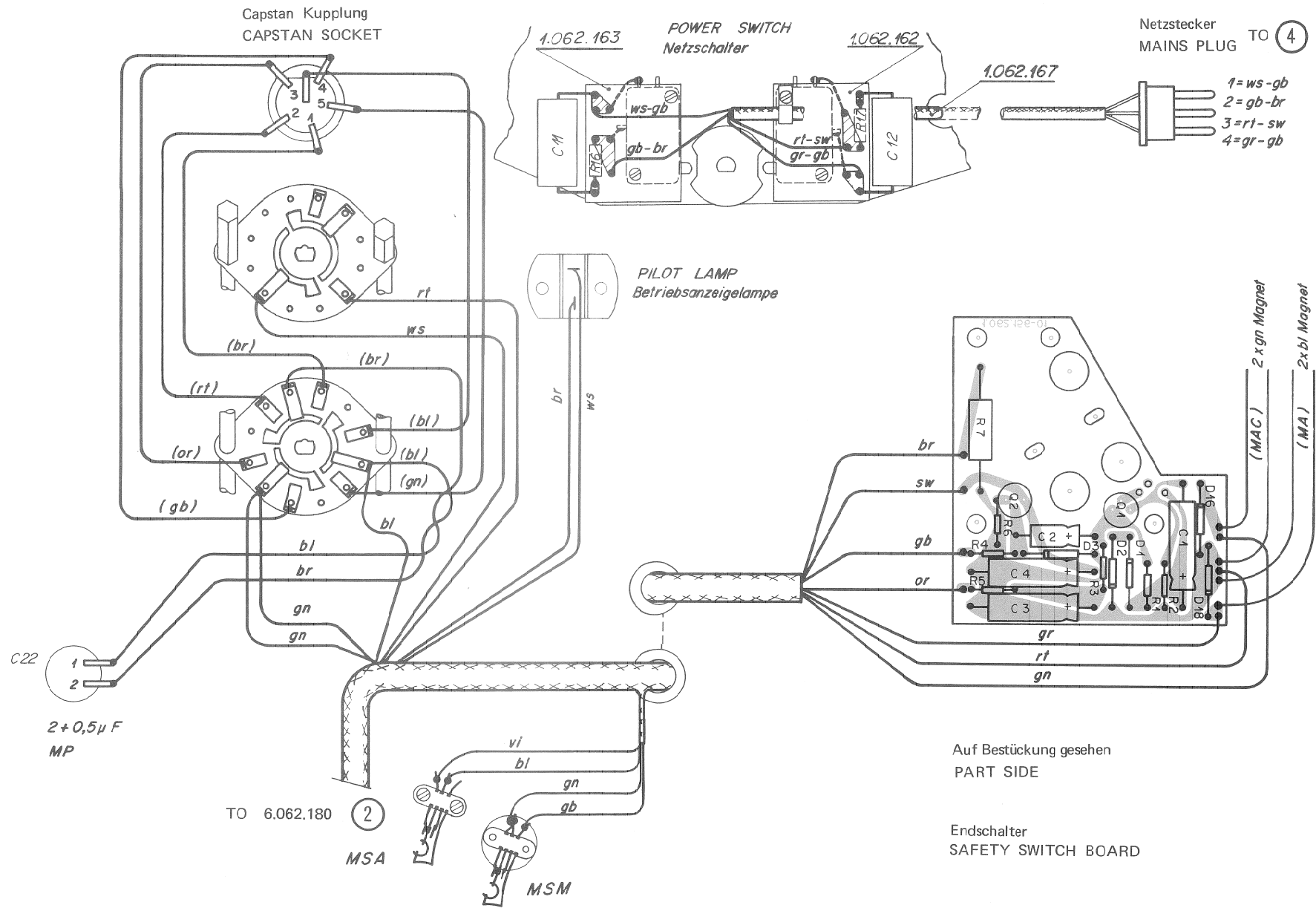

TO 6.062.180 (2)

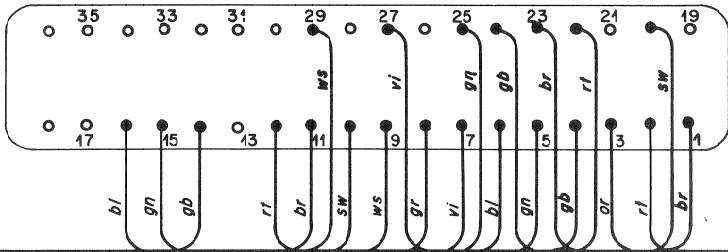

TO 6.062.200 Bl.2 (5)

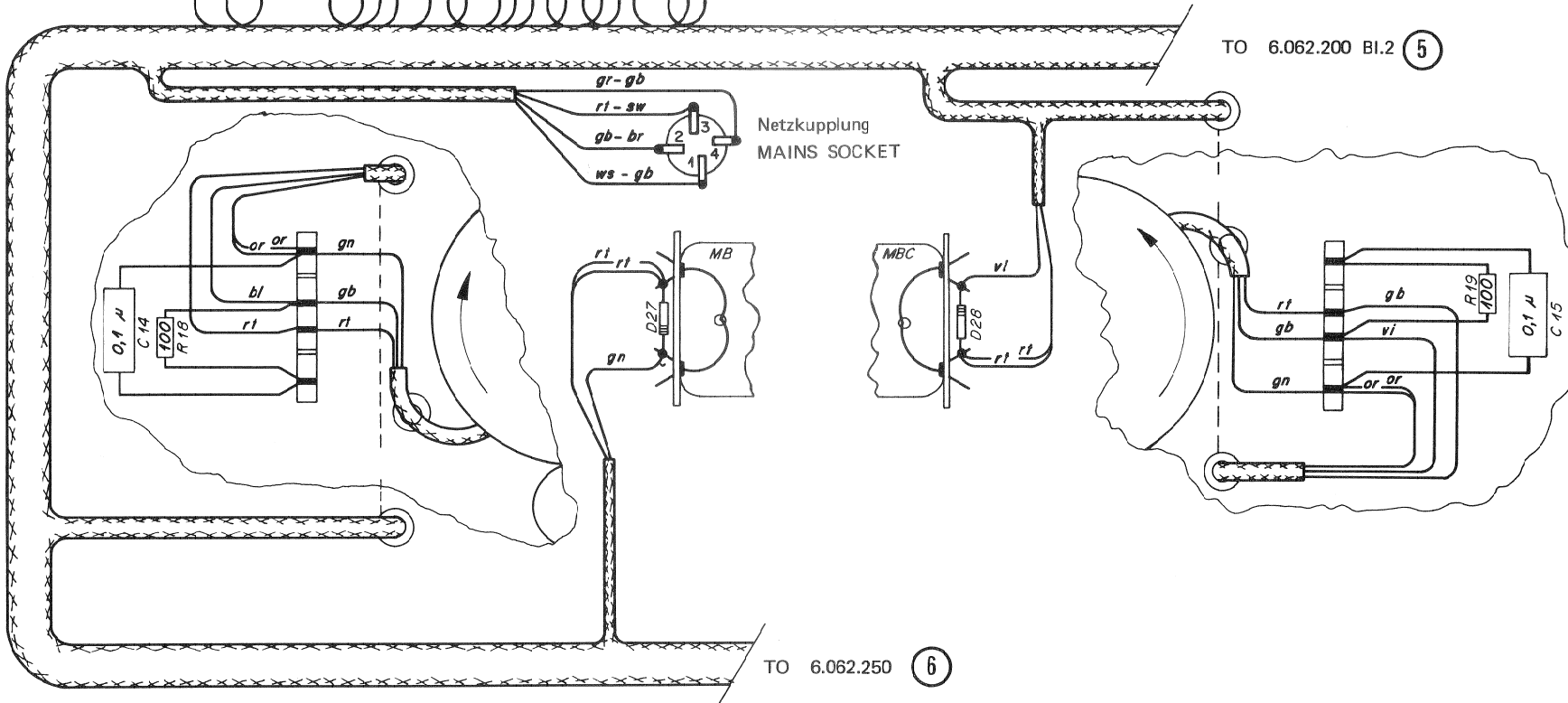

TO 6.062.250 (6)

TO 6.062.180 (2)

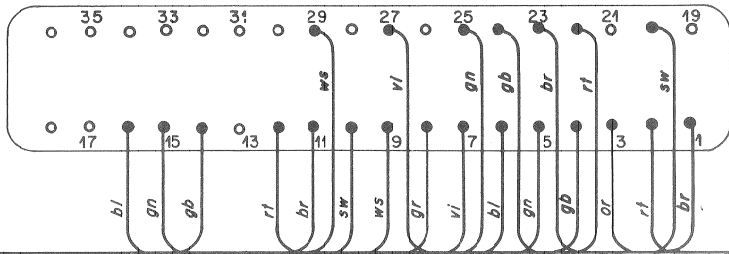

TO 6.062.200 BL.2 (5)

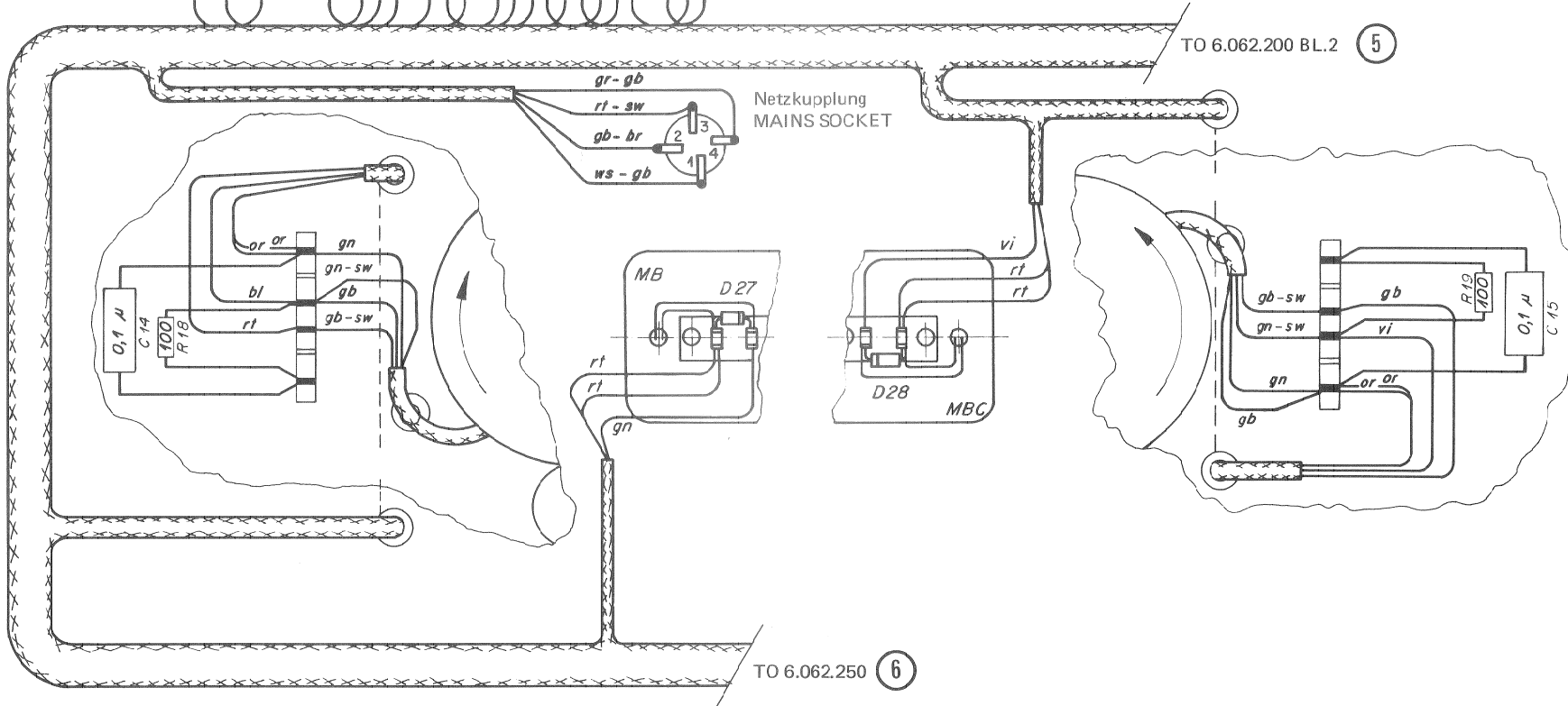

TO 6.062.250 (6)

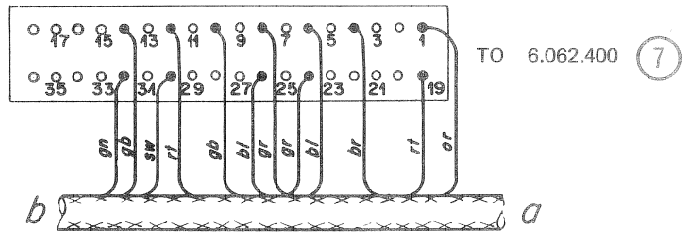
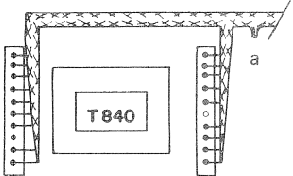
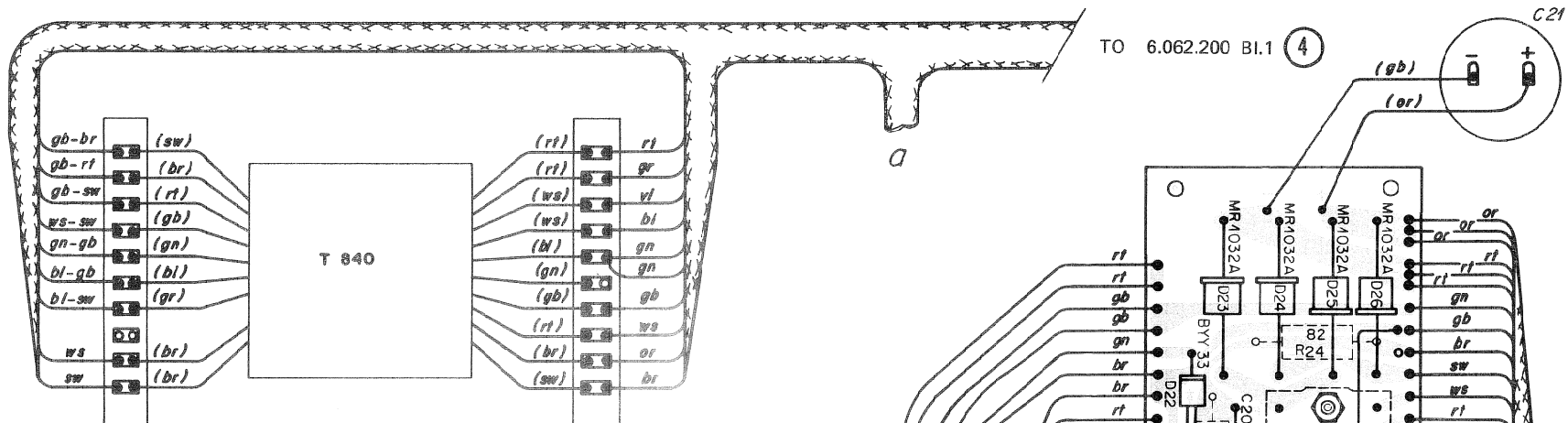

1.062.286
1.062.283
zum Magnetverstärker
TO MAGNETIC AMPLIFIER

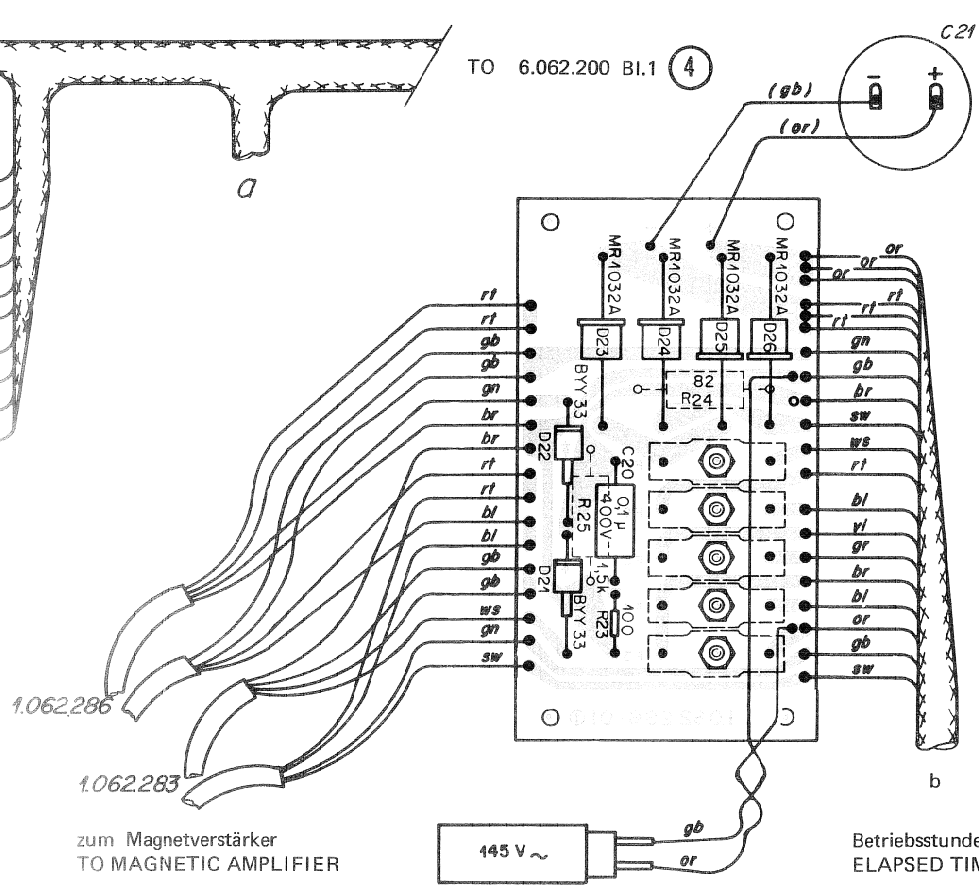

- F7 = 3,15A
- F6 = 1 A
- F5 = 0,5A
- F4 = 0,5A
- F3 = 1 A

145 V ~
Betriebsstundenzähler
ELAPSED TIME METER

Auf Bestückung gesehen.
PART SIDE

R24 und R25 sind nur in 3,75" / 7,5" Maschinen eingebaut.
R24 and R25 in 3,75" / 7,5" MACHINES ONLY.

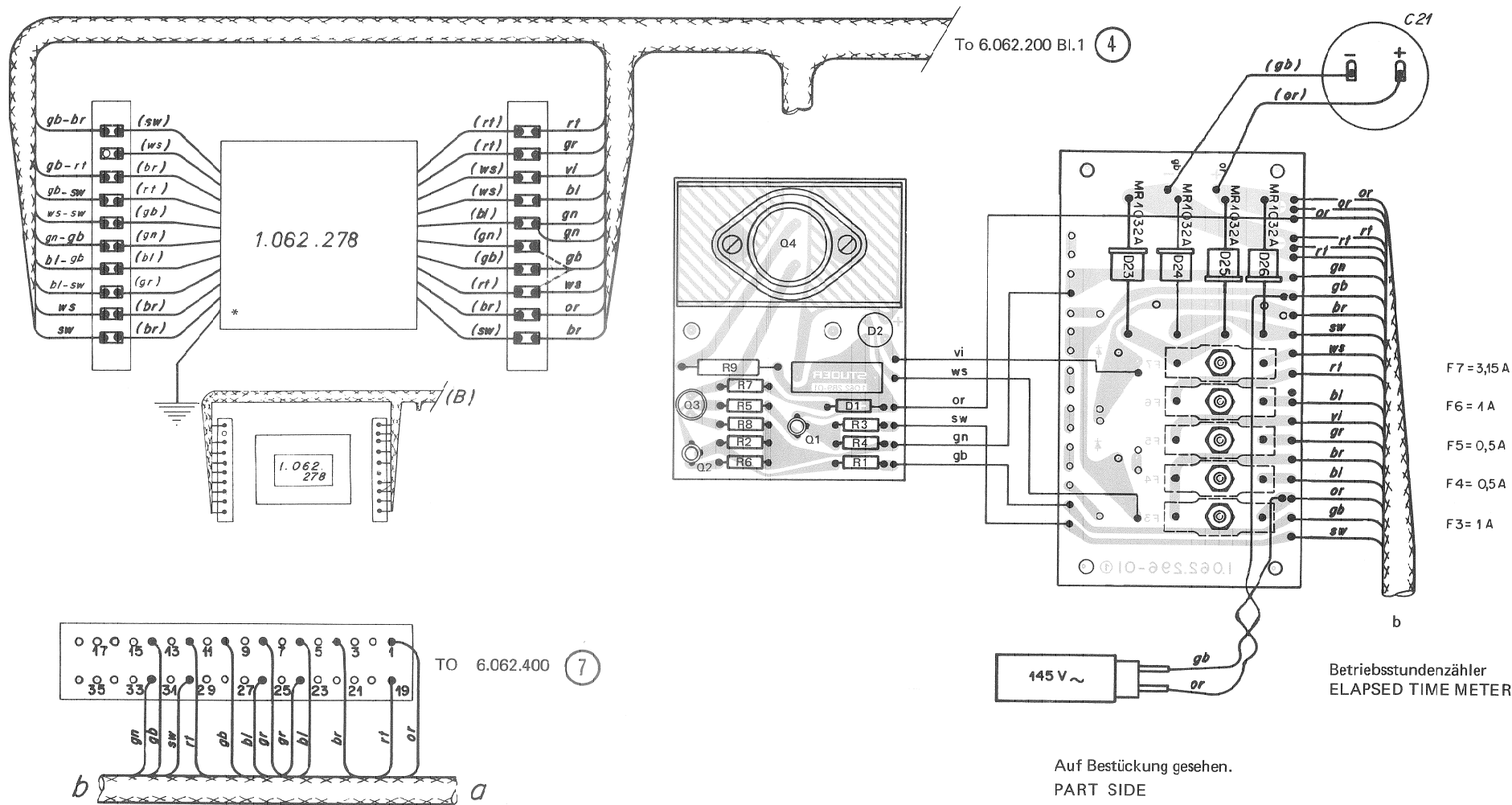

*Bei einer Netzspannung von 100 V ist die Zuführung (gb-rt) am Trafo von (br) auf (ws) umzulöten.

*When operating from line voltages of less than 100 V resolder the wire connection (gb-rt) on the transformer from (br) to (ws).

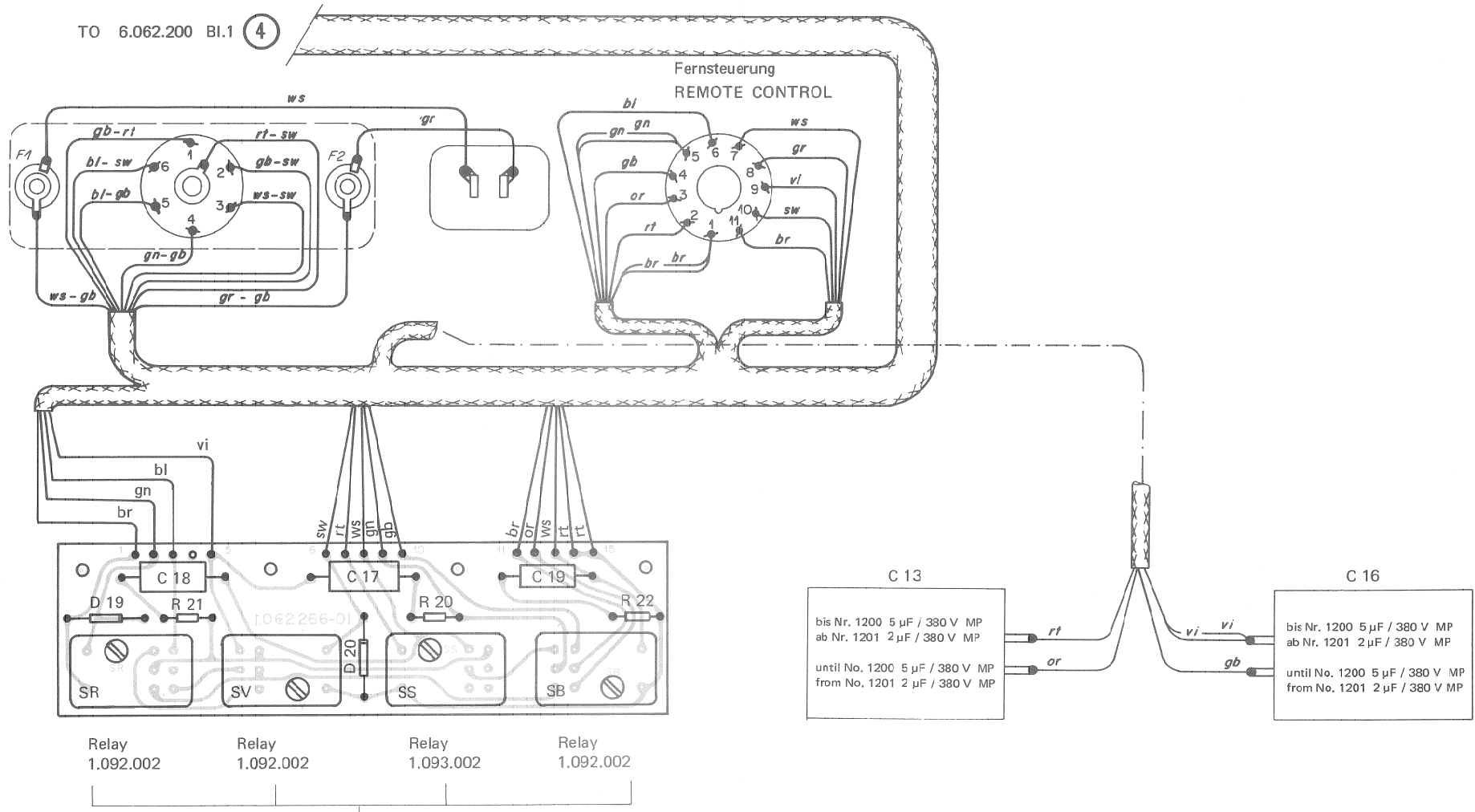

Relaisplatte
RELAY BOARD

Auf Kaschierung gesehen
PRINTED SIDE

Einlegeliste
Wiring list

- br M19 - aA
- gn M24 - bB
- gn M26 - bA
- rt M30 - aU
- gb M32 - aT
- ws M 1 - cF
- sw M 4 - eH
- gr M 6 - bU
- gr M 8 - bV
- vi M10 - cH
- or M12 - aB
- bl M14 - aV

- br aA - cA
- or aB - cB
- gb aC - bN
- sw aD - bM
- rt aE - bH
- gb bT - cC
- gb bS - eC
- gb bR - dT
- gb bP - fT
- sw bM - cD
- bl bL - eD
- bl bK - dS
- bl bJ - fS
- rt bF - cE
- rt bE - eE
- rt bD - dR
- rt bC - fR
- ws cF - eF
- br dV - eA
- or dU - eB
- ws eF - G
- bl fS - G

TO (8) (9) (10)

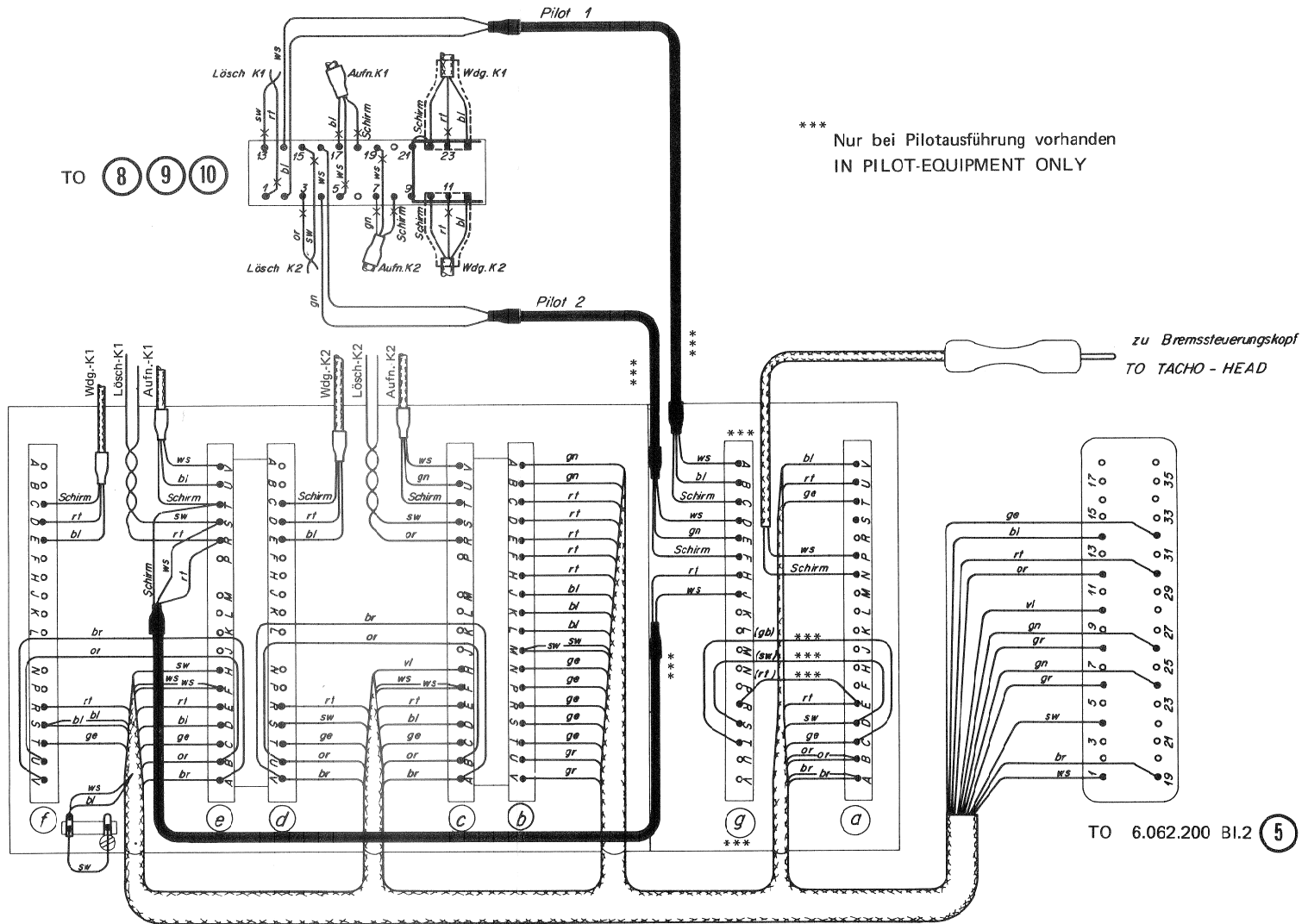

STUDER A62
6.062.401 (400)

VERSTÄRKERKORB (PILOT)
WIRING CARD BOX (PILOT)

(7)

- | | | |
|---|-------------------------|--------|
| a | TAPE TENSION CONTROL | Nr. 15 |
| b | POWER SUPPLY | Nr. 11 |
| c | RECORD AMPLIFIER CH 2 | Nr. 22 |
| d | PLAYBACK AMPLIFIER CH 2 | Nr. 19 |
| e | RECORD AMPLIFIER CH 1 | Nr. 22 |
| f | PLAYBACK AMPLIFIER CH 1 | Nr. 19 |
| g | PILOT AMPLIFIER | Nr. 17 |

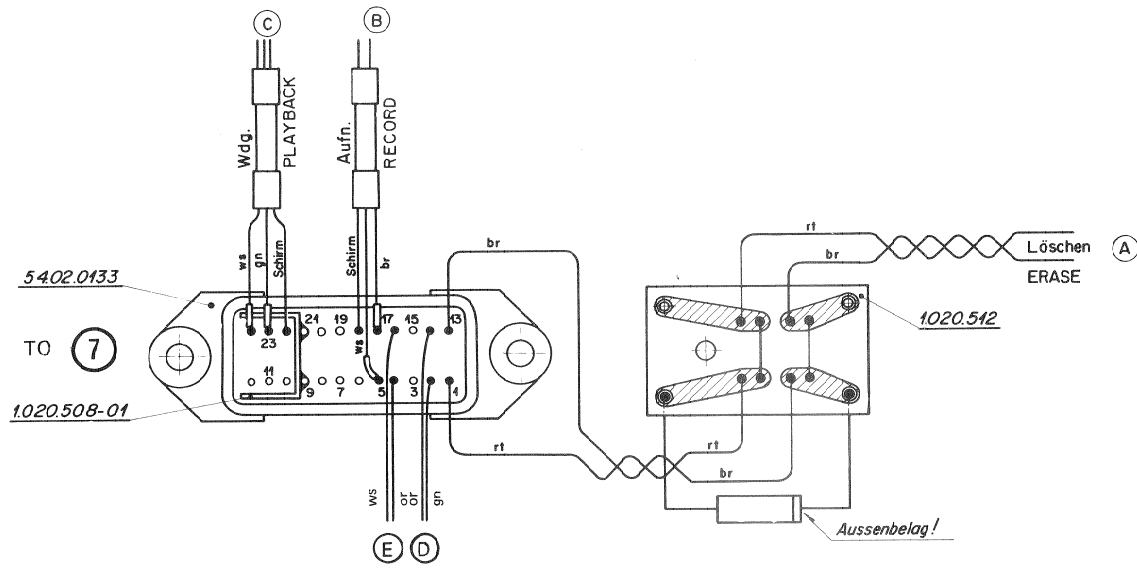

5402.0133

TO 7

1020.508-01

Auf Kaschierung gesehen.
PRINTED SIDE

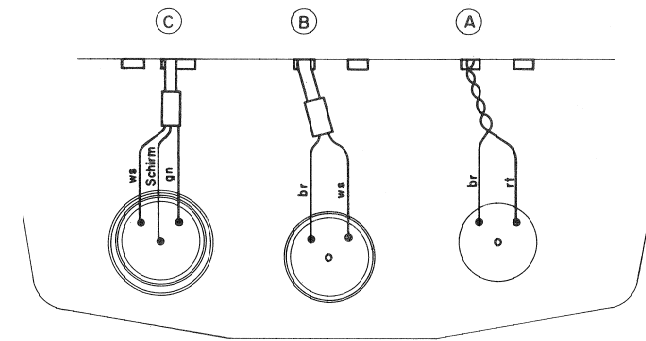

Kopfträger, Vollspur 1/4"
HEAD ASSY. FULL-TRACK 1/4"

6.020.500

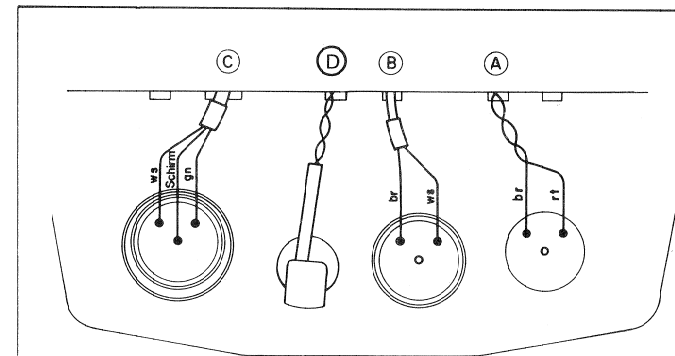

Kopfträger, Transversal-Pilot, 1/4" Vollspur
HEAD ASSY., TRANSVERSAL-PILOT, 1/4" FULL-TRACK

6.020.530

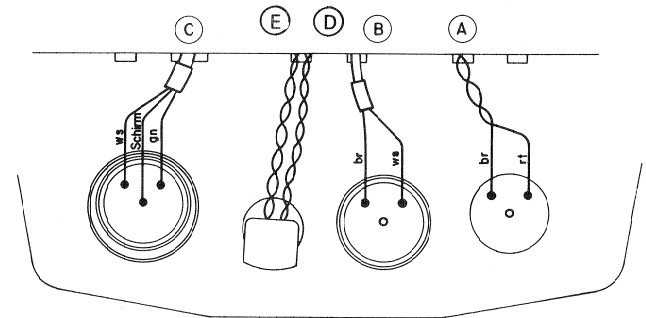

Kopfträger, Neopilot, 1/4" Vollspur
HEAD ASSY., NEOPILOT, 1/4" FULL-TRACK

6.020.540

STUDER A62

1.020.508
1.020.568

ANSCHLUSSSTECKER
HEAD ASSY. CONNECTOR

KOPFTRÄGER
HEAD ASSY.

VOLLSPUR / HALBSPUR
FULL-TRACK / HALF-TRACK

VOLLSPUR
FULL-TRACK

8

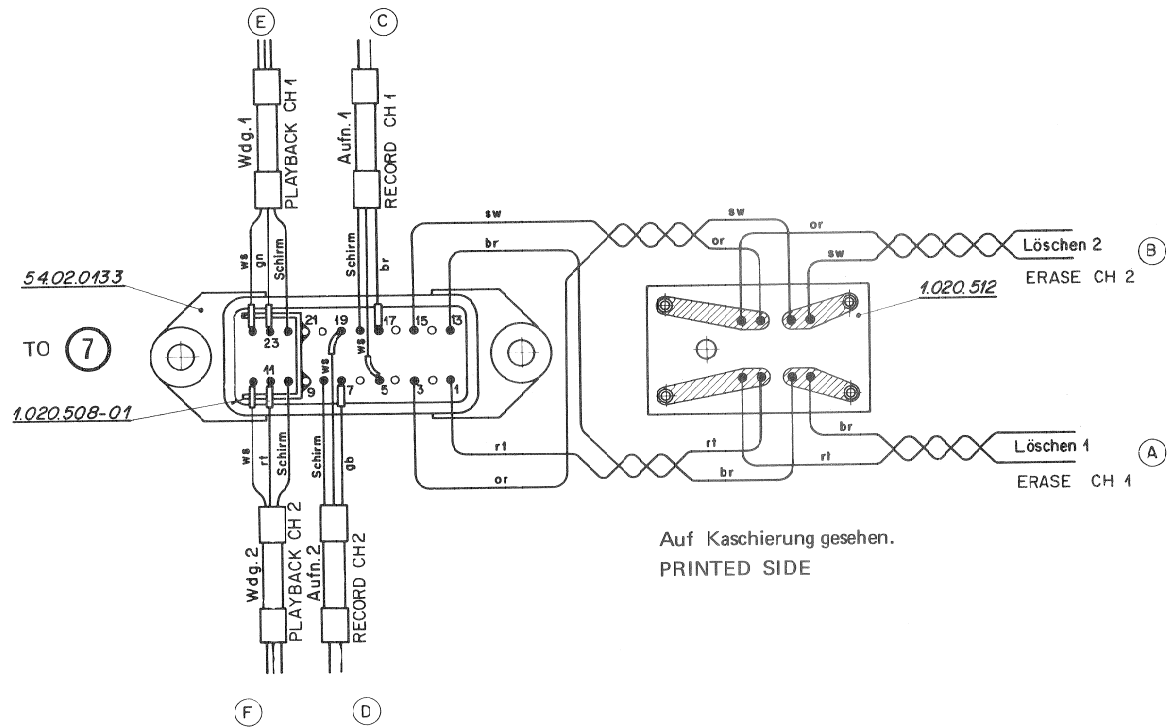

Auf Kaschierung gesehen.
PRINTED SIDE

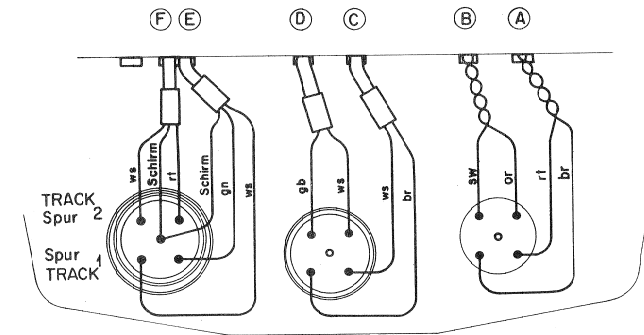

Kopfträger, 1/4" Zweispur
HEAD ASSY., 1/4" DUAL-TRACK

6.020.520

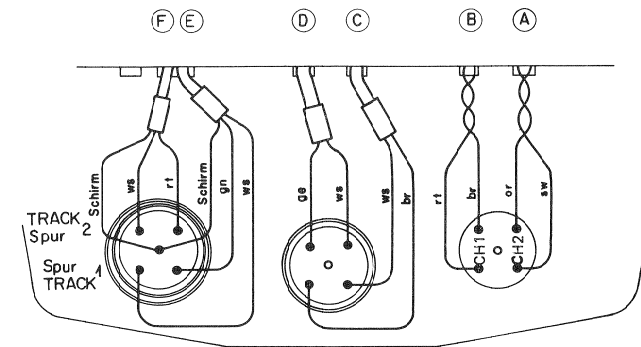
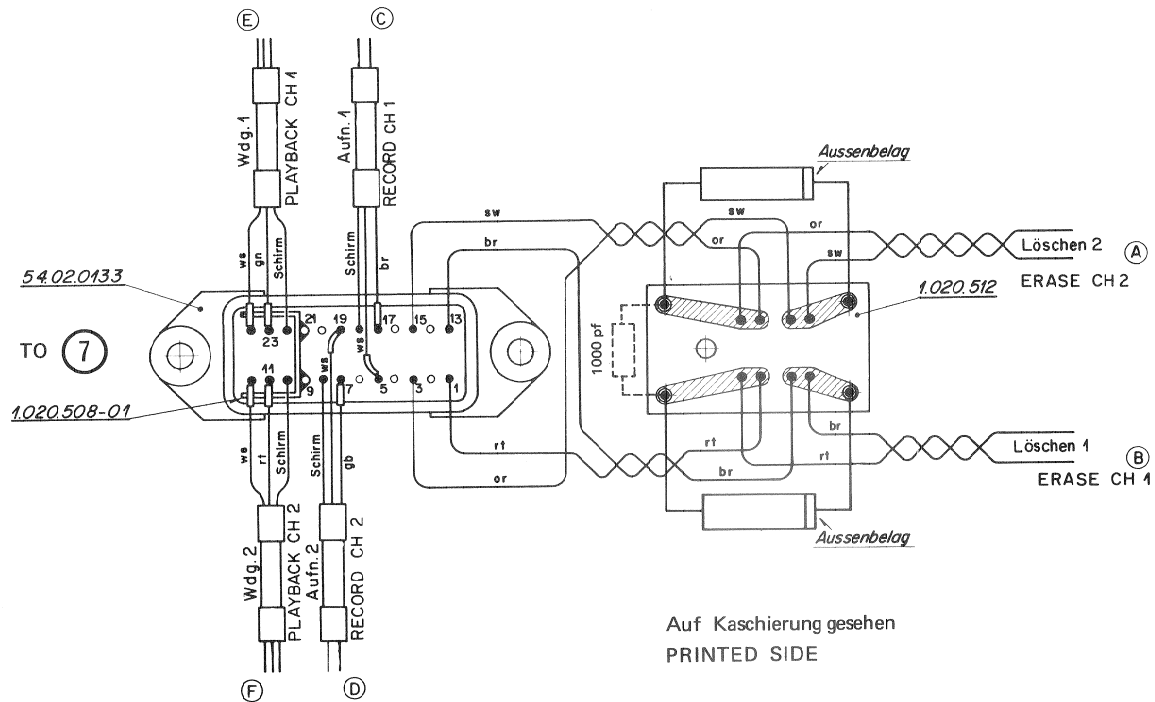

Kopfträger, 1/4" Stereo 2mm
HEAD ASSY., 1/4" STEREO 2mm 6.020.570

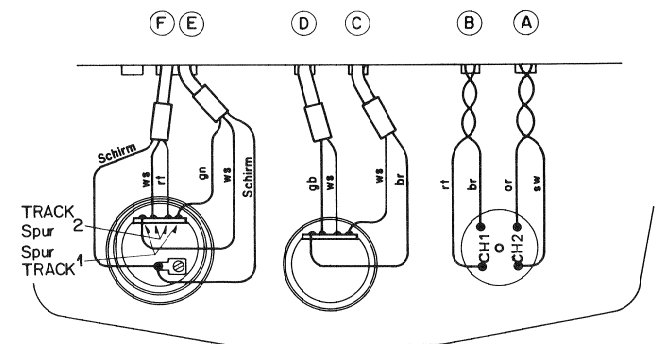

Kopfträger, 1/4" Stereo 0,75mm
HEAD ASSY., 1/4" STEREO 0,75mm 6.020.550

STUDER A62
1.020.558

ANSCHLUSSSTECKER STEREO
HEAD ASSY. CONNECTOR STEREO

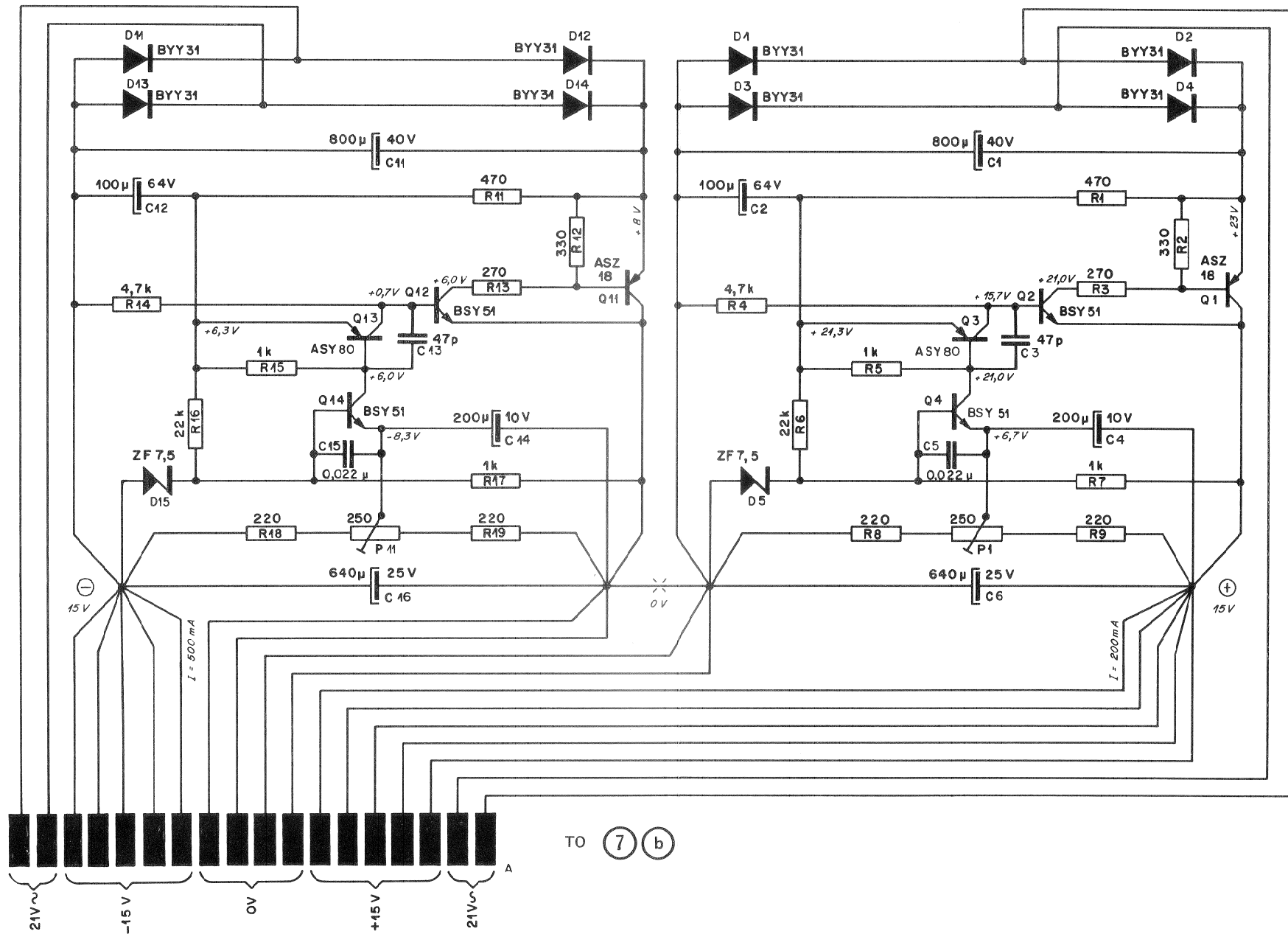

TO (7) (b)

STUDER A62
7.062.520

STABILISATOR
POWER SUPPLY

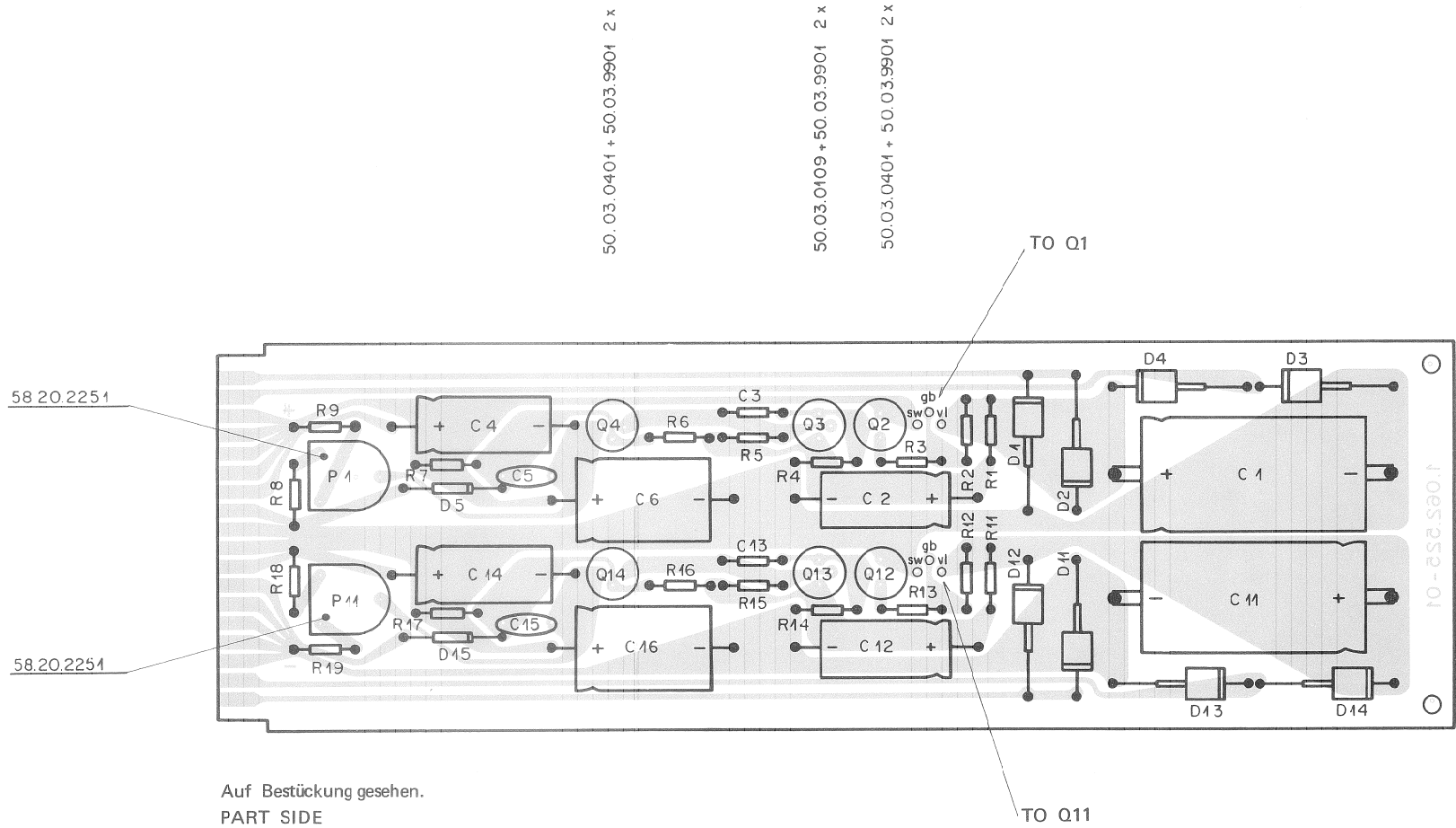

Auf Bestückung gesehen.
PART SIDE

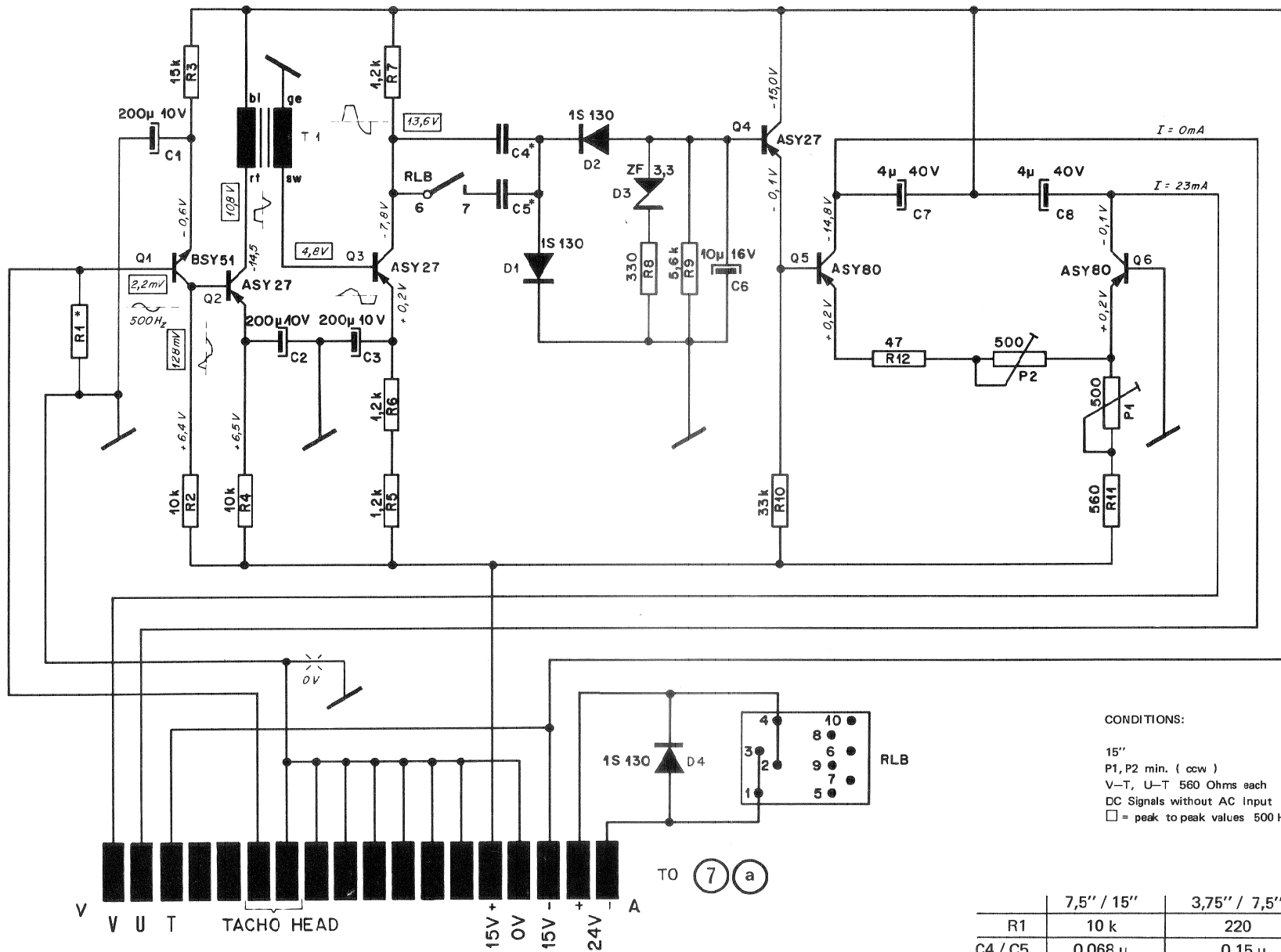

CONDITIONS:
 15"
 P1, P2 min. (ccw)
 V-T, U-T 560 Ohms each
 DC Signals without AC Input
 □ = peak to peak values 500 Hz

	7,5" / 15"	3,75" / 7,5"
R1	10 k	220
C4 / C5	0,068 µ	0,15 µ

STUDER A62
 7.062.620

BREMSSTEUERUNG
 TAPE TENSION CONTROL

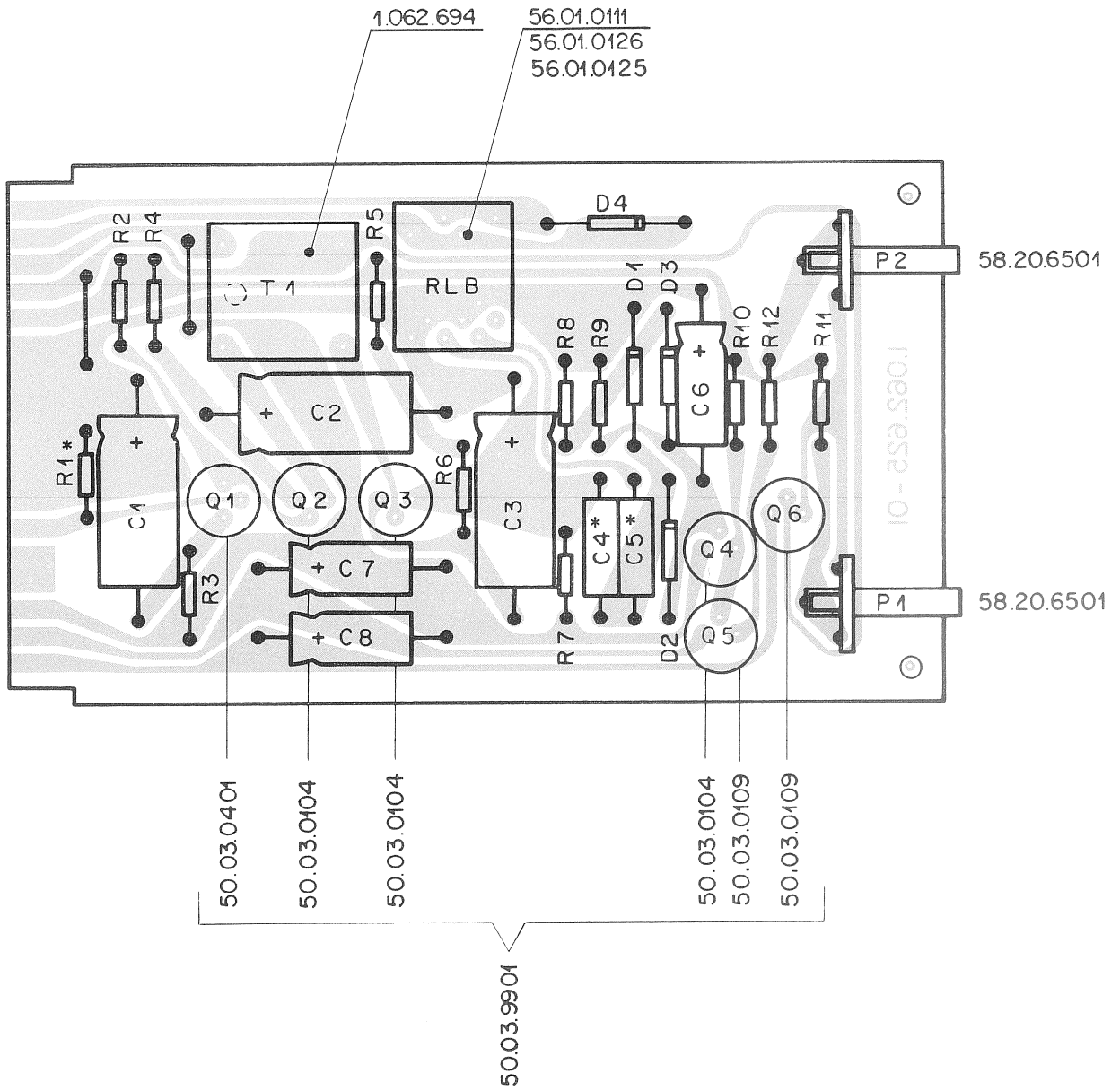

Auf Bestückung gesehen.
PART SIDE

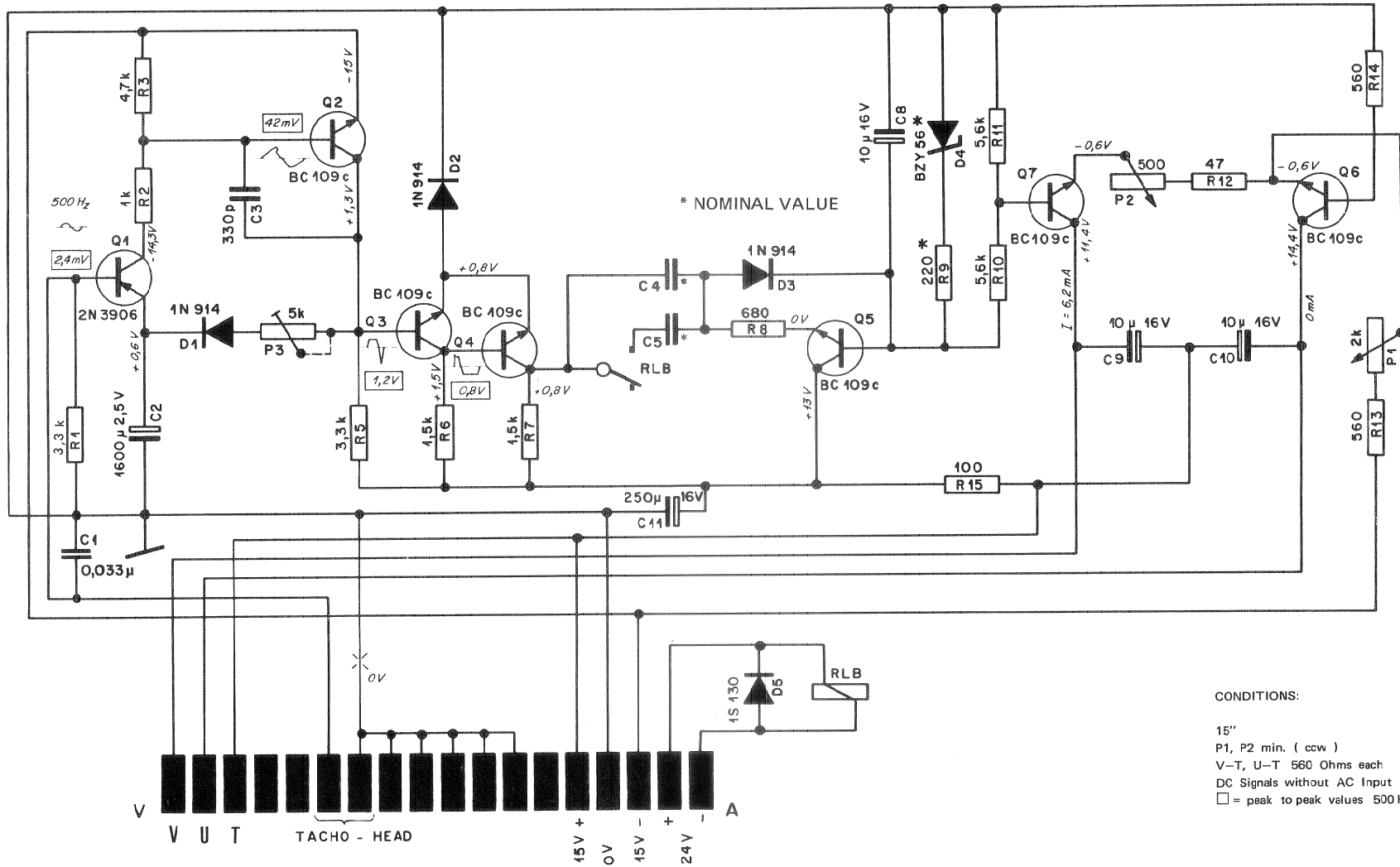

* NOMINAL VALUE

CONDITIONS:
 15"
 P1, P2 min. (ccw)
 V-T, U-T 560 Ohms each
 DC Signals without AC Input
 □ = peak to peak values 500 Hz

TO (7) (a)

	7,5" / 15"	3,75" / 15"
C4 / C5	0,068 µ	0,15 µ

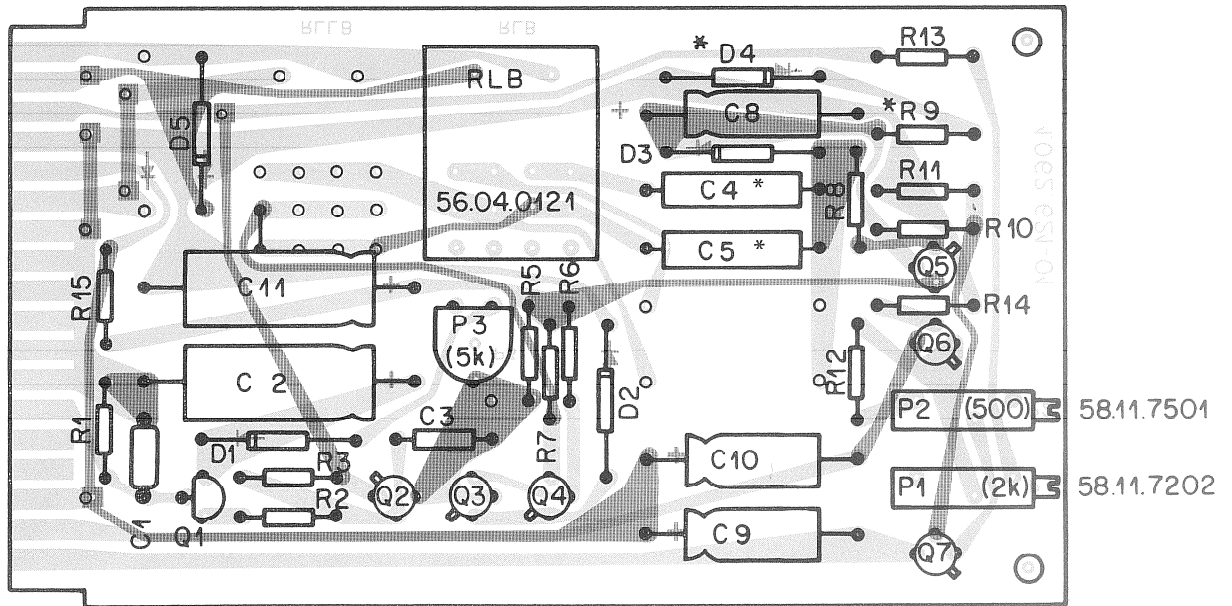

Q1 = 2N 3906 = 50.03.0304
 Q2 -Q7 = BC 109c = 50.03.0407

* NOMINAL VALUE

Auf Bestückung gesehen.
 PART SIDE

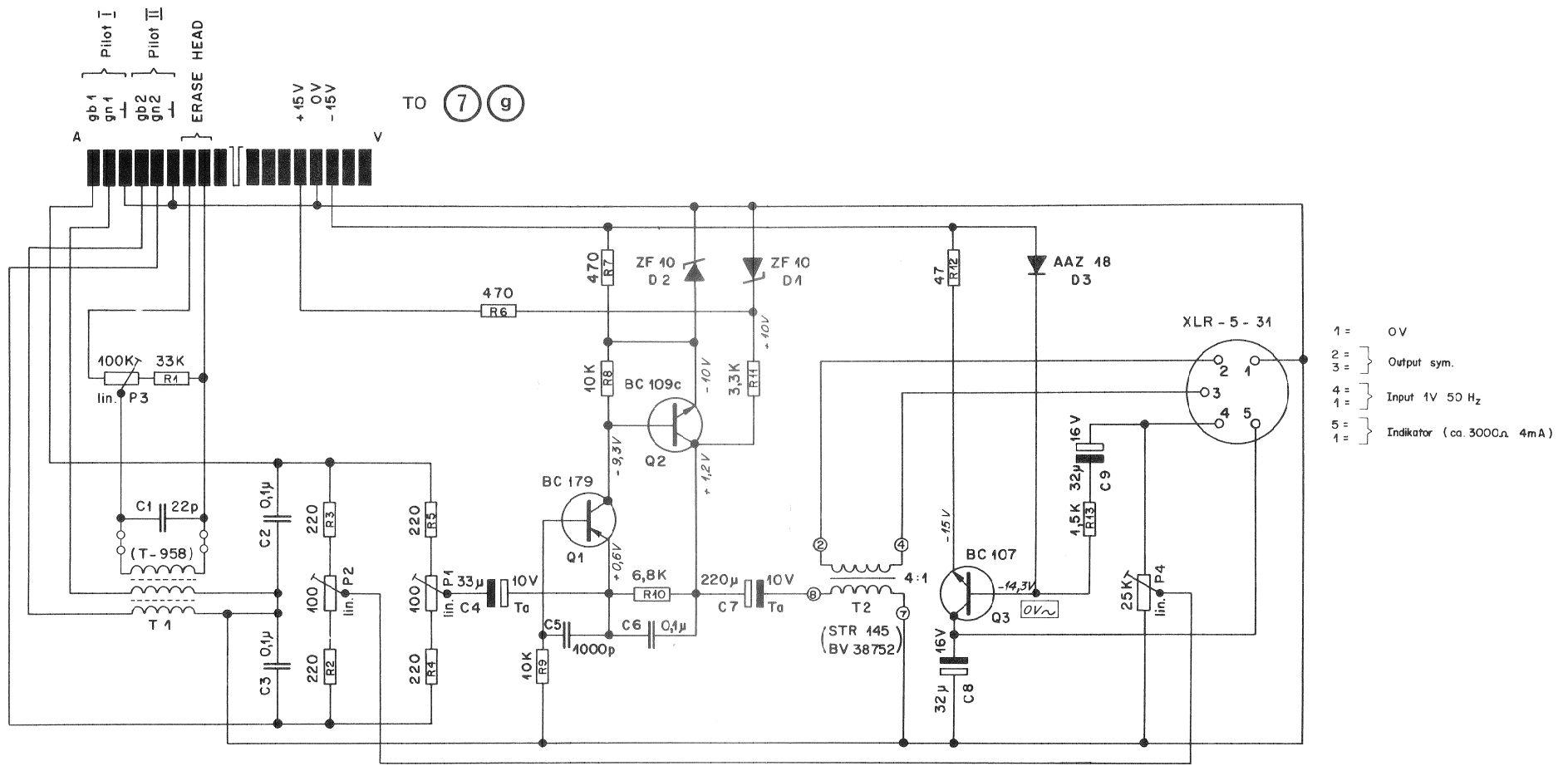

STUDER A62
7.062.670

PILOTTON-VERSTÄRKER
PILOT AMPLIFIER

1.062.690
 21.99.0115
 22.01.8030
 64.01.0101

58.20.2104

62.01.0102

59.31.6104

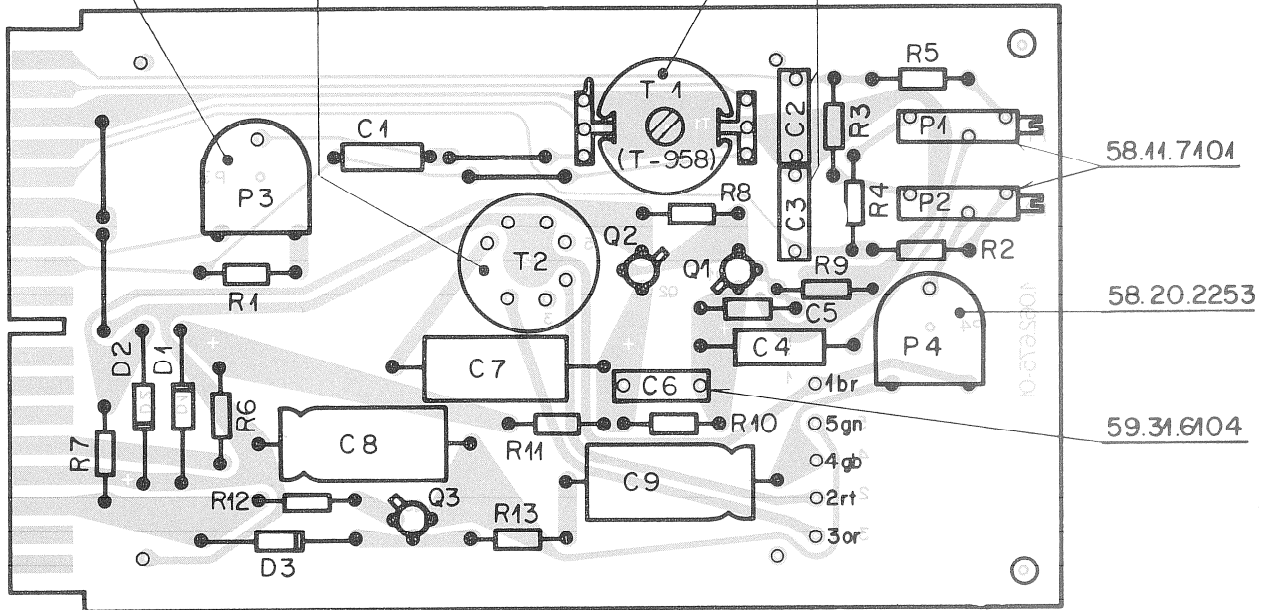

- Q₁ = 50.03.0305 / BC 179
- Q₂ = 50.03.0407 / BC 109c
- Q₃ = 50.03.0408 / BC 107

Auf Bestückung gesehen
 PART SIDE

STUDER A62

1.062.670

PILOTTON-VERSTÄRKER
 PILOT AMPLIFIER

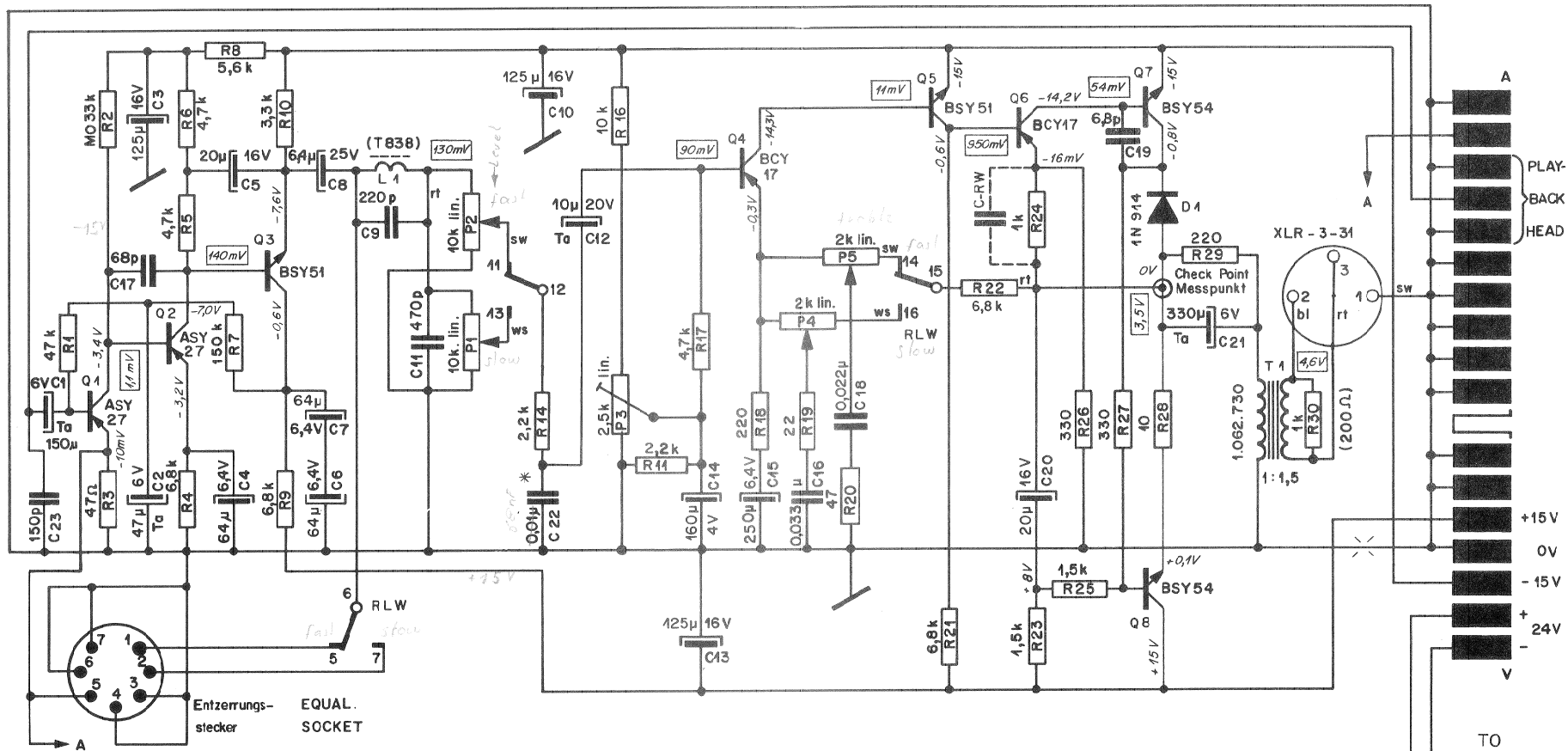

Verbindung A ab ca. Masch. Nr. 800
 A-A CONNECTION WIRED IN MACHINE
 NUMBERS > 800

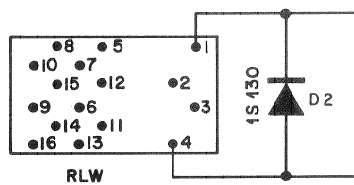

CONDITIONS:

- 15" Playback Position
- P1, P2 max. (ccw)
- P4, P5 Min. (ccw)
- = U_{off} 1 kHz

TEST INPUT CIRCUITRY

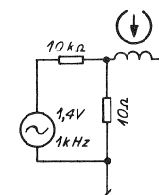

STUDER A62
 7.062.720

WIEDERGABE-VERSTÄRKER
 PLAYBACK AMPLIFIER

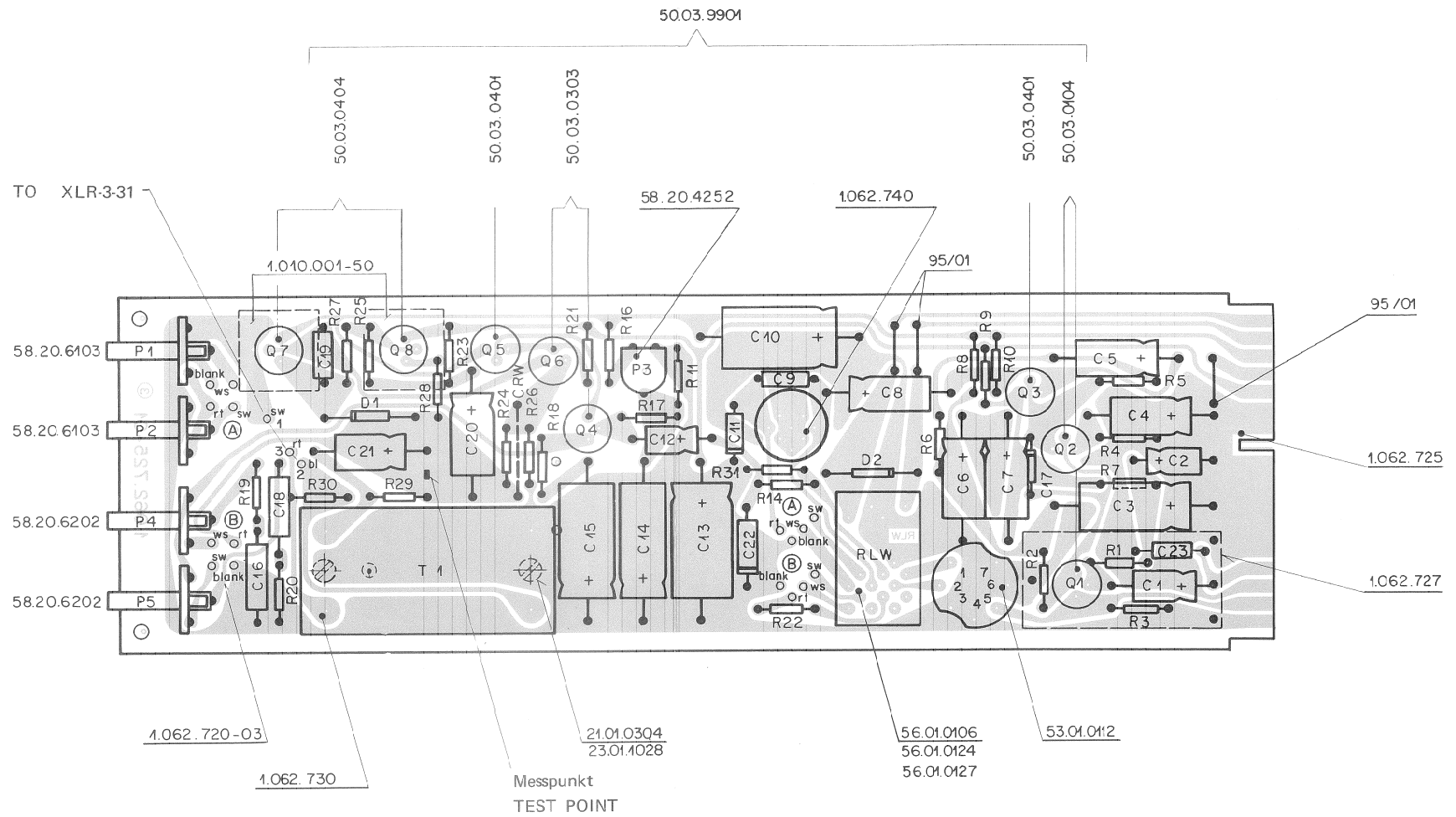

Auf Bestückung gesehen
PART SIDE

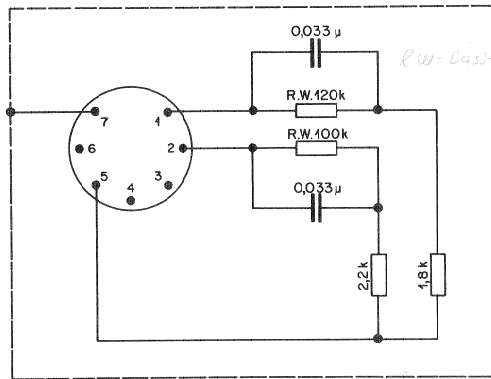

CCIR 70 us + 90 us 7.062.464

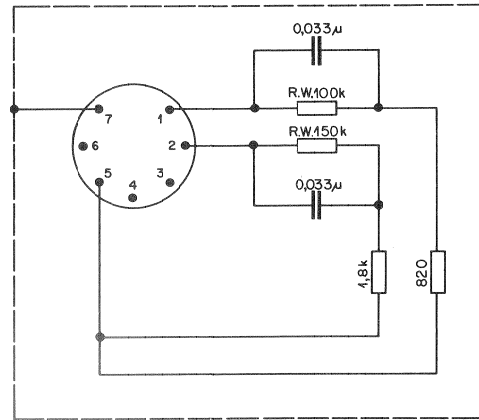

CCIR 35 us + 70 us 7.062.465
Zweispur
DUAL-TRACK

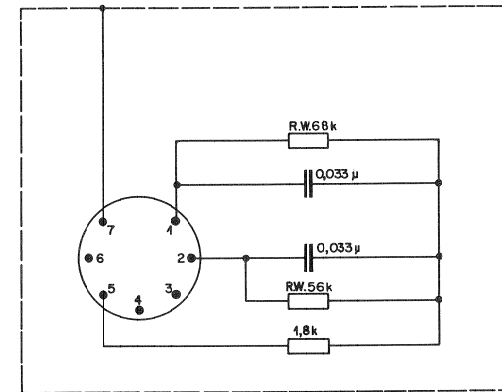

NAB 50 us + 50 us 7.062.480
Zweispur
DUAL-TRACK

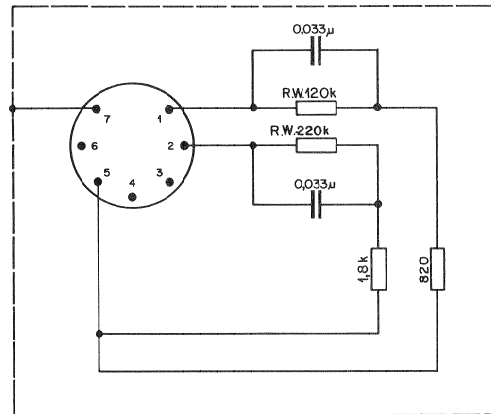

CCIR 35 us + 70 us 7.062.460
Vollspur / Halbspur
FULL-TRACK / HALF-TRACK

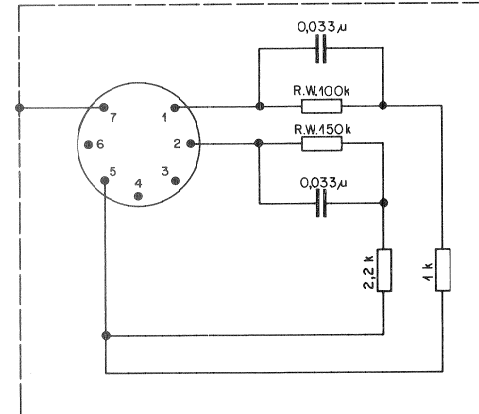

CCIR 35 us + 70 us 7.062.466
STEREO 0.75 mm

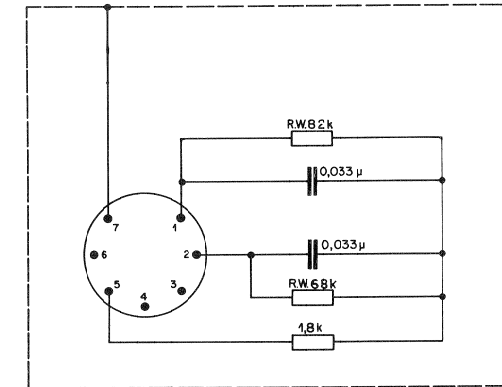

NAB 50 us + 50 us 7.062.475
Vollspur
FULL-TRACK

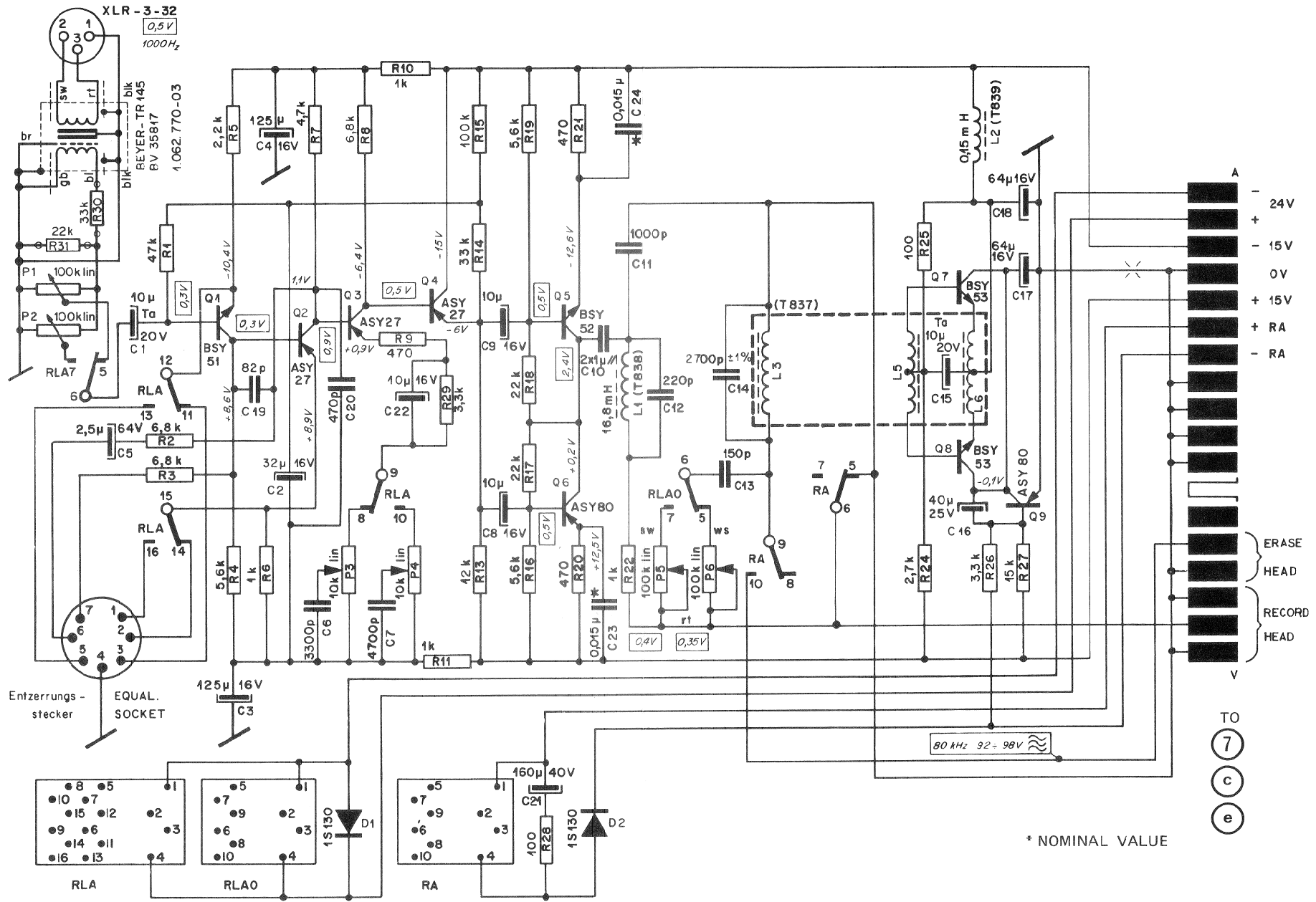

* NOMINAL VALUE

CONDITIONS:
 15" Record Position
 P1, P2 max. (cw)
 P3, P4 Min. (ccw)
 □ = U_{off} 1 kHz
 For AF measurement only
 disconnect L2.

STUDER A62
 7.062.770

AUFNAHME-VERSTÄRKER
 RECORD AMPLIFIER

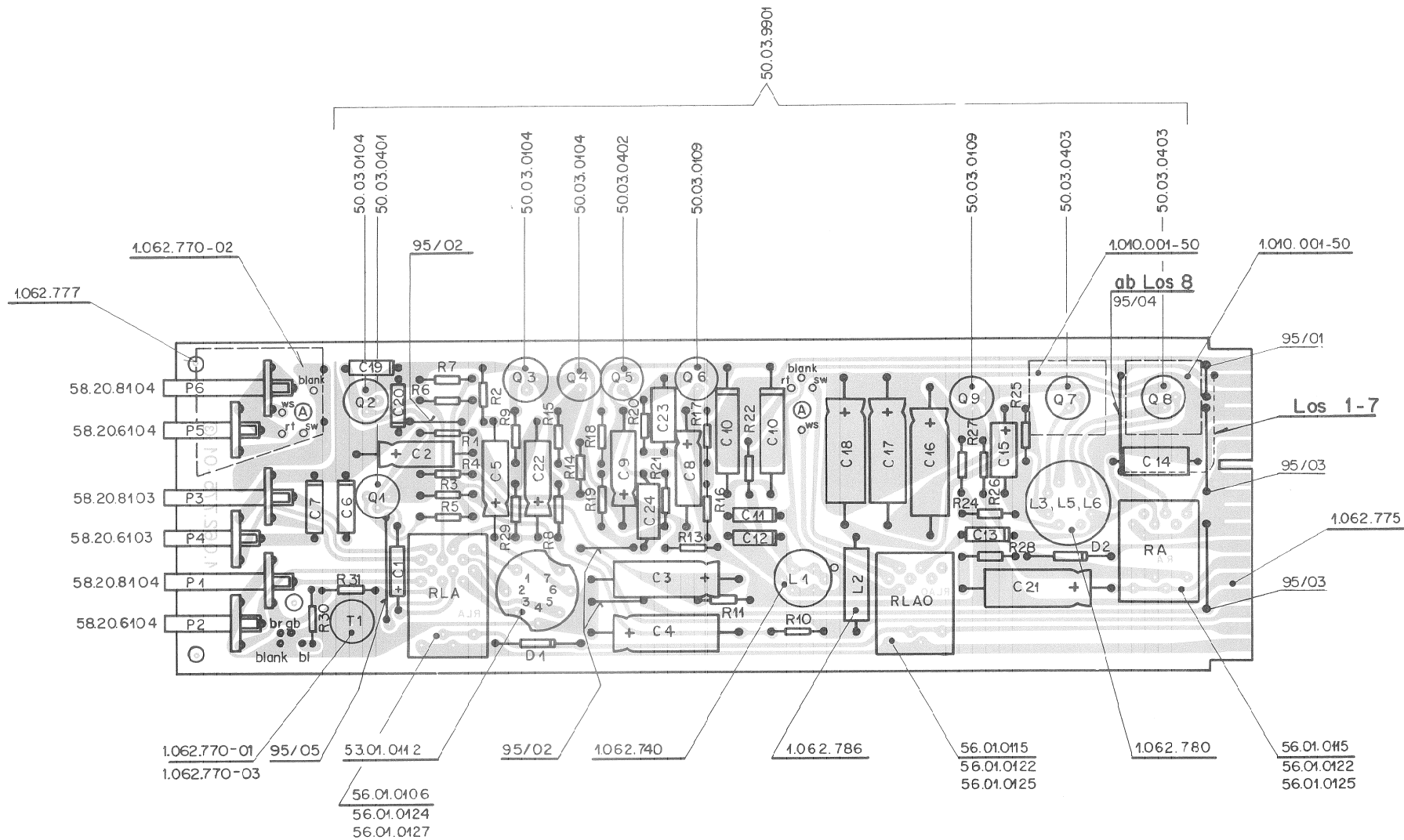

Auf Bestückung gesehen
PART SIDE

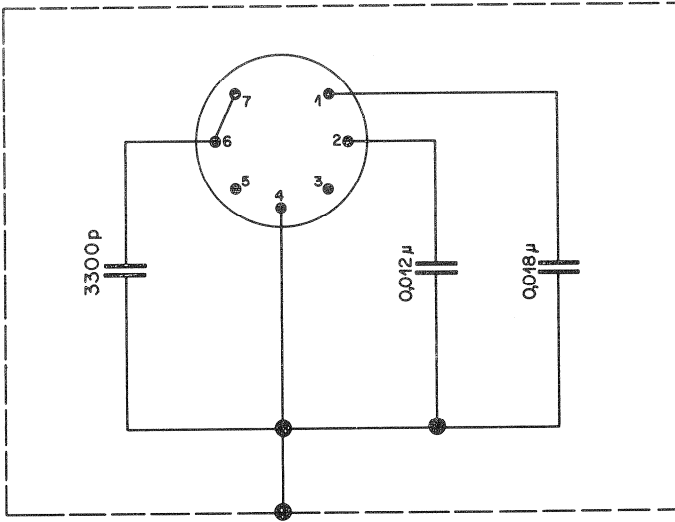

CCIR 35 us + 70 us 7.062.450

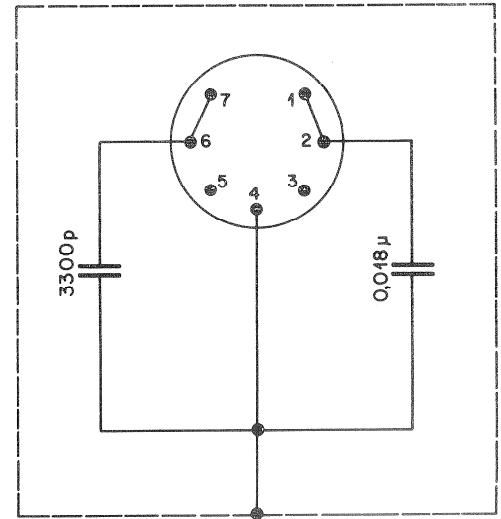

CCIR 70 us + 90 us 7.062.454
Vollspur
FULL-TRACK

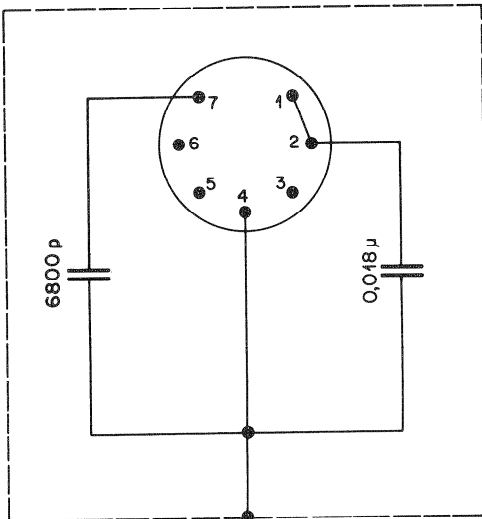

CCIR 70 us + 90 us 7.062.455
Halbspur / Zweispur / Stereo
HALF-TRACK / DUAL-TRACK / STEREO

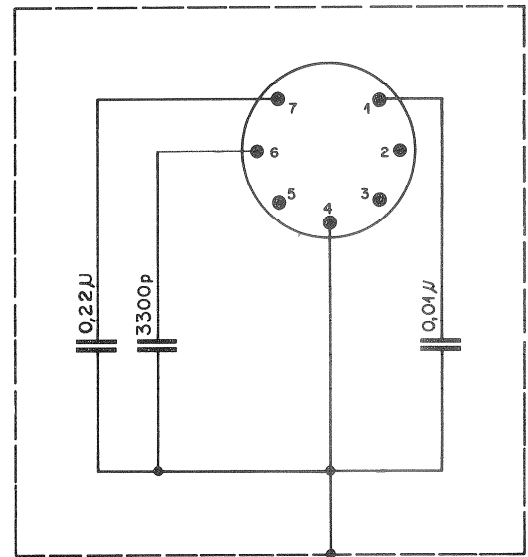

NAB 50 us + 50 us 7.062.470

Änderungen – Modifications

Zu Schaltbild 22, "Aufnahme-Verstärker"

Eine zusätzlich eingebaute Vordämpfung durch die Widerstände R30/R31 erleichtert die Pegelvorregelung (P1/P2) für hohe Eingangssignale.

Für niedere Eingangspegel sind folgende Änderungen vorzunehmen: R 30 kurzschließen, R 31 entfernen.

Re Schematic 22, "Record Amplifier"

The additional fixed attenuation which is given by the resistors R30/R31 facilitates level adjustments through P1/P2 for high input signals.

To accommodate low input signals, the following modification is required: Insert wire-strap across R 30, remove R 31.

zu Bild 17: Capstanmotor mit Kugellager

Re illustration 17: Capstan Motor with Ballbearing

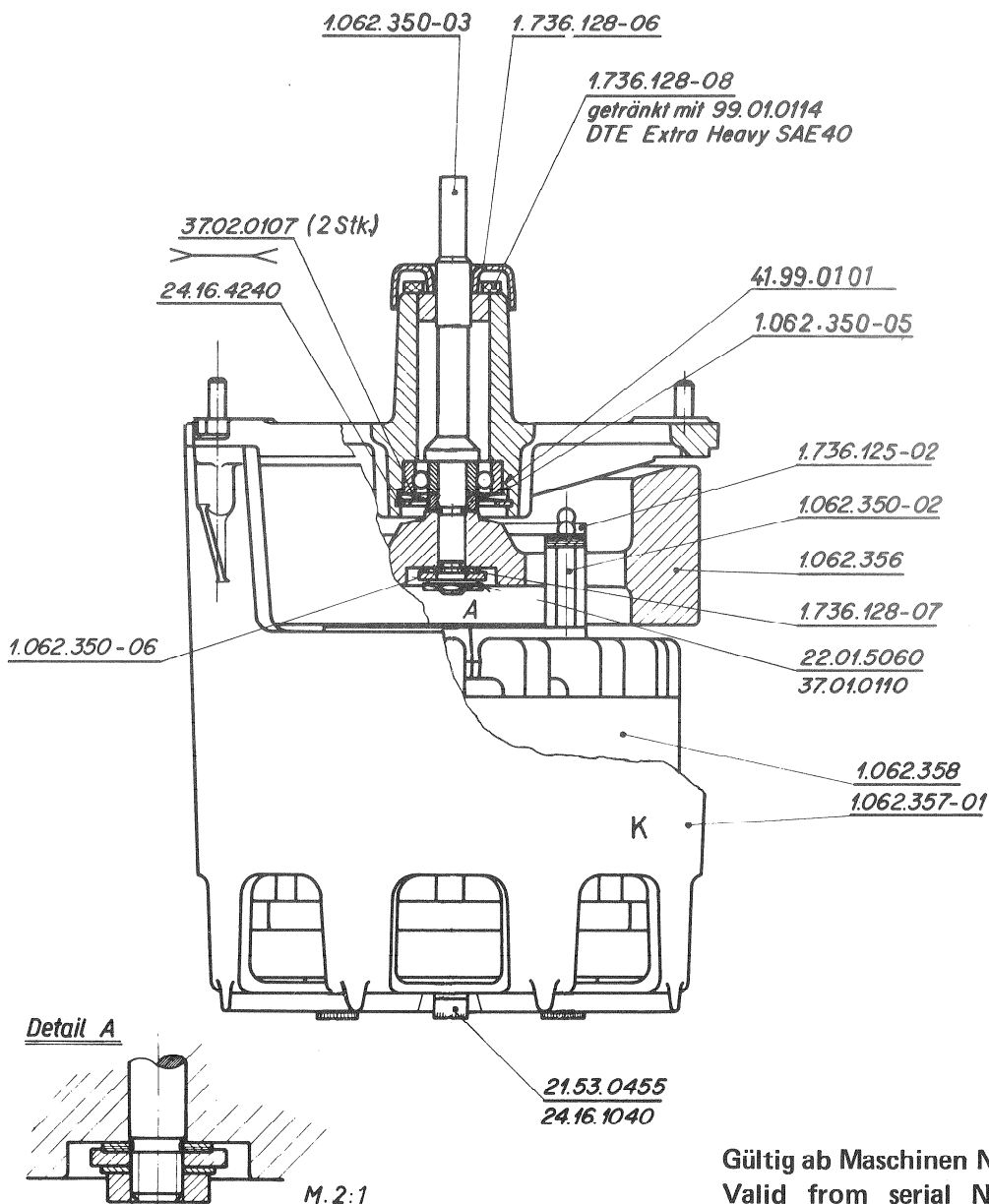

Gültig ab Maschinen Nr. 566
Valid from serial No.



Bild 12

Im Zusammenhang mit den stärkeren Wickel-
motoren wurde der Magnetverstärker durch
einen Bremsverstärker ersetzt. Der Abgleich
ist wie folgt vorzunehmen:

1. Zener Diode D 4 auslöten (Bremssteuerung, Schema 15)
2. Der Abgleich ist bei der kleinen Geschwindigkeit vorzunehmen.
3. Auf Abwickelteller ein Wickel von 25 cm \varnothing auflegen. Abgleich erfolgt mit P 1. (Siehe Bild 23)
4. Band vorspulen bis auf der Abwickelseite ein Wickeldurchmesser von 15 cm erreicht ist. Abgleichen mit P 2.
5. Punkte 3 und 4 wiederholen bis Bandzug ca. 70 g.
6. Bei einem Wickeldurchmesser von 10 cm links, verschiedene Zenerdioden-Typen ausprobieren, bis Bandzug grösser als 63 g. (Z-Dioden-Richtwert 3,9 – 5,1 V)
7. Bei einem Wickeldurchmesser von 6 cm links, geeigneten Wert für Widerstand R 9 aussuchen, bis Bandzug grösser als 55 g.
8. Punkte 3,4 und 6 nochmals kontrollieren, ev. nachgleichen.

In conjunction with the more powerful spooling motors, the magnetic amplifier has been replaced by a hold back amplifier.

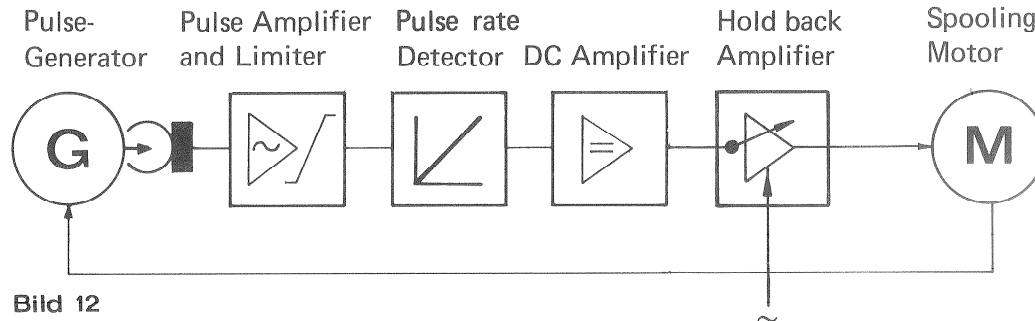
Adjustment of the tape tension control is to be carried out as follows:

1. Unsolder Zener diode D 4 (Tape tension control, schematic 15)
2. Adjustment is to be carried out at the lower tape speed.
3. Place a tape reel of 10 inch diameter onto the supply side. Adjustment to be carried out with P 1. (See illustration 23)
4. Wind tape onto take up side until a reel diameter of about 6 inches is reached, carry out adjustment with P 2.
5. Repeat the operations of points 3 and 4 until tape tension is approx. 70 g.
6. With a reel diameter of 4 inches left, try various Zener diodes until the tape tension reaches a value of more than 63 g.
7. With a reel diameter of 2,5 inches left, select a value for R 9 which produces a tape tension of more than 55 g.
8. Re check points 3,4 and 6 and readjust if necessary.