

dynakit

SCA-35

SERIAL NUMBER

15350075

This number must be mentioned in all communications concerning Dynakit.

STEREO CONTROL AMPLIFIER

INSTRUCTIONS FOR ASSEMBLY AND OPERATION



Price \$1.00

Patented

086315

DYNA COMPANY

DYNACO

3916 POWELTON AVE.
PHILADELPHIA 4, PA.

CONTENTS

Operation of Controls	3
Connections to Music System	4
Initial Adjustments and Installation	5
Connecting a Center Loudspeaker	5
Connecting Headphones	6
Technical Circuit Description	7
Assembly Instructions	9
240 Volt Power Transformer	16
In Case of Trouble	17
Schematic Diagram	19
Service and Warranty	21
Parts List	21

SPECIFICATIONS

Inputs:	7 pairs: RIAA magnetic phono low level, magnetic phono high level (50,000 ohms); Ceramic phono; NAB 7½ i.p.s. tape head (100,000 ohms); radio, tape, spare (250,000 ohms)
Outputs:	Constant level tape output, 8 and 16 ohm loudspeaker outputs, center-channel loudspeaker output, provision for headphone connection.
Controls:	Selector, Volume, Balance, Bass, Treble, Stereo-Mono Switch, Loudness Compensation Switch, Filter Switch, Power Switch.
Tone Control Range:	± 12 db at 50 cps and 15 kc.
Sensitivity for Rated Output:	2.5 mv at tape head, 4 mv at low level magnetic phono, 1 volt at high level inputs.
Power Output:	35 watts continuous, 45 watts IHF Music Power (both channels).
Frequency Response:	± 0.25 db from 20 cps to 20 kc.
Power Response:	20 cps to 20 kc without exceeding 1% distortion within 1 db of 17.5 watts (each channel).
IM Distortion:	Less than 1% at 17.5 watts (each channel). Less than 0.2% on any input at average listening levels.
Hum and Noise:	70 db below rated output on low level inputs. 80 db down on high level inputs.
Tube Complement:	12AX7/ECC83 (2), 7199 (2), 6BQ5/EL-84/7189 (4).
Silicon Diodes:	500 MA, 1000 PIV (2).
Power Consumption:	110 watts, 120 volts 60 cycle AC, or 120/240 volts 50/60 cycle AC with optional PB-028 power transformer.
Special Features:	Attractive Champagne-gold anodized aluminum front panel and die-cast knobs; 2 AC convenience outlets; provision for headphone output or center-channel level control; center speaker output; power transformer sealed in special encapsulating material for coolest, quietest operation.

INSTRUCTIONS FOR ASSEMBLY AND OPERATION OF THE DYNAKIT SCA-35 STEREO CONTROL AMPLIFIER

The SCA-35 is a high quality stereo preamplifier and amplifier combination which serves as a control center for various program sources such as phonograph, tape and radio. The SCA-35 permits selection of the program source desired, modification of the tonal characteristics of the sound source, and change of volume; it provides output connections for loudspeakers and headphones.

The connection of various types of program sources is made on the back panel through the several sockets provided. The shielded audio cables and plugs supplied with the program source equipment are used for connection between these components. There are screw terminals for connection of loudspeakers to the unit. The upper row of inputs and outputs is used for the left channel, and the bottom row for the right channel.

FRONT PANEL CONTROLS

The front panel controls have been designed to make the operation of the SCA-35 simple and obvious while providing suitable flexibility. Although it is possible to enjoy use of the SCA-35 using only the power and selector switches and the volume control, knowledge of the function of the other switches and controls can provide increased listening pleasure. Each of these will be described briefly.

Selector Switch

Rotation of the selector switch to the marked positions permits use of the marked input source. After switching to "phono" for example, start the record player, and its signal will be available to you.

The stereo-mono switch beneath the selector switch extends its utility. For stereo signal sources, leave the switch in the "stereo" position. When a mono source is being played, the "mono" position of the switch brings this single channel signal through both loudspeakers. When playing monophonic recordings with a stereo cartridge, the "mono" position eliminates most of the vertical noise components of the signal. When a stereo FM tuner is tuned to a monophonic station, the "mono" position of the switch frequently eliminates noise and distortion.

Volume Control

Clockwise rotation of the volume control increases the level of the signal through both loudspeakers. The normal setting of the control will depend on the efficiency of the loudspeakers and the size of the signals from the cartridges and/or tuners. It should be recognized that the position of the control is not related to the power level at which music is played—you may have a wide range of settings to give a specific sound level. Adjustment should be made to the loudness level desired without regard to the position of the knob pointer.

If the tuner, or other input equipment, has its own level setting or volume control, this should be set so that when switching from one input to another, the sound is close to the same loudness.

Beneath the volume control is the loudness switch. When it is switched to "loudness" there is additional bass intro-

duced into the music when the volume control is at the mid-point or below. At high settings of the volume control, the loudness switch has no effect. The reason for this feature is that the human ear has decreased sensitivity to low frequencies at low volume levels, and the loudness switch helps to correct for this. It will add a fullness to low level music which can enhance its pleasure.

Balance Control

The balance control is used to equalize the signals at the two loudspeakers, which helps to center the sound. Turning the balance control to the left will diminish the sound to the right speaker, thus making the sound source move to the left. Turning to the right will move the sound source to the right.

Normally the balance control is centered when it is in the mid-point (12 o'clock), but differences in programming, in speaker efficiencies, in room acoustics, and in component tolerance in the SCA-35 may require a setting off the mid-point. Since the effects of this control are very gradual in the area of rotation from 9 o'clock to 3 o'clock, offsetting it in this region does not indicate abnormality.

When rotated to either extreme, the balance control cuts off one speaker completely. This can be used if different signals appear in the two stereo channels (such as the reverse track of a mono tape machine), and the two are not wanted simultaneously.

Tone Controls

The bass and treble controls operate in similar fashion with the treble control affecting high frequencies, and the bass control the low frequencies. Each of these gives "flat" response without frequency discrimination when the pointer is at 12 o'clock. Clockwise rotation provides boost, and counter-clockwise rotation gives attenuation.

When program sources are harsh or strident, treble attenuation will improve the sound. If there is boominess, bass attenuation should be used. Some thin sounding material can benefit from bass boost. These controls should be set to whatever position sounds best, but it should be remembered that departures from "flat" are of a corrective nature; and the user should not get in the habit of listening to a corrected tonal characteristic.

Beneath the tone controls is the filter switch. When this is in the "filter" position it gives a narrow band response, attenuating both high and low frequencies simultaneously. This should be used with poor program material, such as scratchy records, excessive rumble, noisy radio broadcasts, and so on. By attenuating at both ends of the spectrum, it does not create a shift in overall tonal balance. It can be used in conjunction with the tone controls for great extremes of tonal correction.

Power Switch

The power switch has the obvious function of turning the SCA-35 on and off (along with any equipment in the switched outlet on the back panel). Allow about 15 seconds for warmup after turning this switch to "power."

BACK PANEL CONNECTIONS

Phono Connections

Either a record changer or a professional type turntable can be used. There are three pairs of phono inputs, allowing for use of all types of phonograph cartridges. There is a choice of (1) low level magnetic cartridge, (2) high level magnetic cartridge, or (3) crystal or ceramic type. Most popular magnetic cartridges are of the low level type. However, if the cartridge is rated at more than 20 millivolts this is a high level model, and the high level magnetic input should be used. If you are using a low level magnetic cartridge and find that there seems to be too much amplification when using it in the low level phono input, then the high level magnetic input may be used. This will reduce the total amplification without detriment to performance. Always read instructions which accompany the cartridge to determine whether its manufacturer has any special recommendations for its connections and use.

In many of the turntables and record changers made today there is a separate ground wire. This should be connected to the screw on the back panel of the SCA-35 above the phono inputs. If such a ground wire is not supplied with your phonograph, then it may be necessary to connect a wire, in addition to the audio signal cables from the cartridge, from a ground point on the turntable motor or arm to the grounding screw on the SCA-35. Normally it is not desirable to make further ground connections to water pipes or to an "earth" ground.

If the phono cartridge is a mono one, then it is suggested that you connect its output to only one input (either channel). If you want to hear sound through both channels, turn the stereo-mono switch on the front panel to its mono position to hear the program through both loudspeakers.

Tape Connections

The SCA-35 can be used either with a tape machine which has its own tape amplifier, or playback electronics, or with a tape deck having direct output from the tape head. If the machine has a tape playback amplifier, then the output is at a relatively high level. In this case this output is connected to the input of the SCA-35 marked "From TAPE AMP." If the machine is a deck only, the output is very low and the input marked "From TAPE HD" is used. The tape head input has very high amplification and the required NAB 7½ i.p.s. equalization for tape head playback. Generally, when the tape head input is used, a ground wire must be connected from a specific point on the tape deck (see instructions supplied with tape deck) to the grounding screw on the SCA-35. Try it with and without this ground wire for lowest hum.

If the tape machine has a recording amplifier, you can connect the SCA-35 to the tape machine for recording from the phonograph or from the tuner. The high level input of the tape recorder (not the microphone input) should be connected to the socket marked "To TAPE RECORD." Whatever is being played through the SCA-35 will be recorded unaffected by volume and tone controls of the SCA. Thus you can listen to a program and adjust volume and tone controls to suit, without affecting the signal going into the recorder.

In the special case where it is desired to play a multi-track tape with a monophonic recording on all tracks

through the SCA-35, the track recorded in the opposite direction will come through one channel of the SCA-35 unless one of two expedients is used to prevent this: (1) One cable can be removed from the unwanted channel, then by using the mono position of the stereo-mono switch the sound will come through both speakers, or (2) The balance control can be turned to either extreme position to eliminate sound through the unwanted channel.

The SCA-35 can be used for playing recorded tape, but it cannot be used for recording with a tape deck which has no recording preamplifier.

Radio Connections

Radio tuners which can supply one volt or more audio output can be used with the SCA-35. If the tuner is FM stereophonic, then its left output is connected to the upper radio input and the right output goes to the lower radio input of the SCA-35. If the tuner is monophonic, it can be connected either with a "Y" connector to both radio inputs, or to only one input. If one input is used, you will have to turn the stereo-mono switch to the mono position to receive sound from both speakers.

If the tuner has separate outputs for AM and FM without its own provision for switching these, you may use one (or both) of the radio inputs for FM and the spare inputs for AM. Then selection of FM or AM broadcasts can be made with the selector switch on the SCA-35.

Additional Inputs

The spare input of the SCA-35 will accommodate any type of high level input source which provides one volt or more of audio signal. A second tape machine (having playback electronics built in) or tuner may be used in this input or a second phonograph which includes its own preamplifier.

Loudspeakers

The SCA-35 can provide sufficient power to drive all but the most inefficient loudspeaker systems. Check the specifications of the loudspeaker to determine its impedance. Generally this will be 8 or 16 ohms. The speaker terminals of the SCA-35 are marked for speakers of these values, but these terminals will accommodate a wider range of impedances than marked. For example, the 8 ohm output can be used for speakers of 4 to 11 ohm ratings; the 16 ohm output can be used with speakers from 12 to 20 ohms.

The left channel loudspeaker should be connected to the upper output strip. A pair of wires, such as #18 lamp cord, should be used with one wire going to the common terminal (marked "C") and the other to the 8 or 16 ohm terminal. The right speaker should be similarly connected to the lower output strip. Note that the extreme left hand screws on each strip are connected together by a wire strap. Neither of the two speakers should be connected to these terminals. However, it is possible to connect a third loudspeaker—as a center or remote speaker—to these terminals. Details on this use are given later. It is also possible to connect headphones to the loudspeaker terminals, a subject covered in detail later.

In any music system it is best that both loudspeakers be identical. If this is not possible, the stereo effect may be considerably distorted, and there will be shifting of position of sounds between the speakers in a way which is unrelated to the correct localization of those sounds.

Other Back Panel Connections

There are two AC outlets on the back panel to which the power cords of auxiliary equipment may be connected. One of these outlets is switched in unison with the SCA-35 when the SCA's power switch is operated. The other outlet is not switched and will furnish power at all times that the SCA's power cord is plugged in. The switched outlet may be used to power a radio tuner so that this can be turned on and off with the SCA-35. The unswitched outlet should be used for a turntable, record changer, or tape machine. These devices require mechanical switching and should not be switched automatically when the SCA-35 is turned on or off.

The line cord of the SCA-35 should be plugged into a suitable outlet furnishing nominally 120 volts, 60 cps alternating current (120 or 240 volts, 50 or 60 cycles for export models).

There are two knurled shafts on the back panel which are used for hum adjustment of the two channels. Their function is explained below.

USING YOUR SCA-35

Once the associated equipment is connected to the SCA-35 and you are familiar with the operation of the controls, you are ready to try it out.

Hum Adjustments

Turn the volume down low, set the selector switch on "phono," and turn on the SCA power switch. After the first 15 seconds, advance the volume control slowly until you hear some hum from the loudspeakers. Then turn the balance control to cut off the right loudspeaker, and adjust the left hum control (on the back panel) for minimum hum. Repeat this with the balance control set to cut off the left loudspeaker, adjusting the right channel hum control. These controls should give some minimum point for hum; and this point should be low enough to be inaudible at normal listening levels.

Turn the volume down, place a record on the turntable, and advance the volume until you have a suitable level; then you can adjust balance and tone controls to your satisfaction.

The same setup procedure can be followed with a tape deck, using the tape head input. The minimum hum point will be at about the same point as with phono. If neither phono or tape head inputs are to be used, the hum level will be much lower, and it may be difficult to determine where the minimum settings of the hum controls fall. In this case, since hum should be inaudible, it is not important whether the controls are set accurately.

Phasing Loudspeakers

For best stereo effect, the loudspeakers should be properly phased—an adjustment which is made once and can then be left fixed. Phasing consists of arranging the polarity of the speaker connections so that both speakers function in unison, moving in the same direction at the same time, on monophonic signals.

Switch the stereo-mono switch to "mono." Then adjust the balance so that the sound is equal from both loudspeakers. Stand slightly forward of the speakers at an equal distance from each. Move from side to side while trying to locate the sound source. If the speakers are phased correctly, the source will be in the center, when you are in the center, and will shift smoothly to whichever speaker you approach. If the speakers are phased incorrectly, there will be an abrupt jump in the location of the sound, and it will shift suddenly from one side to the other with little or no apparent centering.

To correct the phasing of the loudspeakers, if it is incorrect, you must interchange the two wires between the SCA-35 and one of the speakers. This can be done either at the amplifier or at the speaker.

Ventilation

When using the SCA-35 it is essential that it have adequate ventilation. This unit dissipates 110 watts of heat, and you can see that there is the same heating effect as with a 110 watt incandescent lamp in a small metal container—the case will get quite warm to the touch, and should have air space above to permit the heat to dispell. There should always be several inches of air space above the unit and behind it. *Never* place anything directly on top of the cover when the amplifier is operating.

Cabinet Mounting

The oversize front panel on the SCA-35 facilitates cabinet installations. The rubber feet are not used.

A supporting shelf installed flush with the bottom of a $3\frac{13}{16}$ " by $13\frac{1}{16}$ " cutout in the cabinet panel is required. A $3\frac{1}{2}$ " square ventilation cutout should be made in the shelf to coincide with the punched-out section of the SCA bottom plate, under the output tubes. A PBK bracket kit, which eliminates the need for the shelf, is available directly from Dynaco for \$2.00. No C.O.D.'s please.

Adequate ventilation is imperative. The warranty does not cover equipment which has been subject to abuse as the result of insufficient ventilation. Cabinet installations frequently require the use of a small circulating fan, particularly where the SCA must be mounted close to a tuner, or where vertical (face up) mounting is necessary. Under no circumstances should the SCA be stacked immediately above or below the Dynatuner.

CONNECTING A CENTER LOUDSPEAKER

Under some conditions it is advantageous to be able to use a center loudspeaker which handles the monophonic signal (sum of left and right channels) derived from the two parts of the stereophonic signal. This center speaker can eliminate the "hole-in-the-middle" effect of speakers which are widely separated. The composite center signal can also be used with a remote loudspeaker for monophonic reproduction in another area. The signal for the center speaker is available on the back panel of the SCA-35 without need for another amplifier.

Connection of the center speaker is accomplished by removing the wire link, or jumper, which connects the left-most screws on the two loudspeaker terminal strips and connecting the two wires from the extra speaker to these two screws. The diagram below also shows how a volume, or level setting, control can be optionally added to control the level of the center speaker. The control itself is a 4 watt, wirewound, potentiometer or rheostat. They are available at all radio parts supply stores.

The control for the center speaker can be connected on the back panel of the SCA using the hole which is available, or it can be connected at the loudspeaker location — this is particularly convenient for a remote speaker.

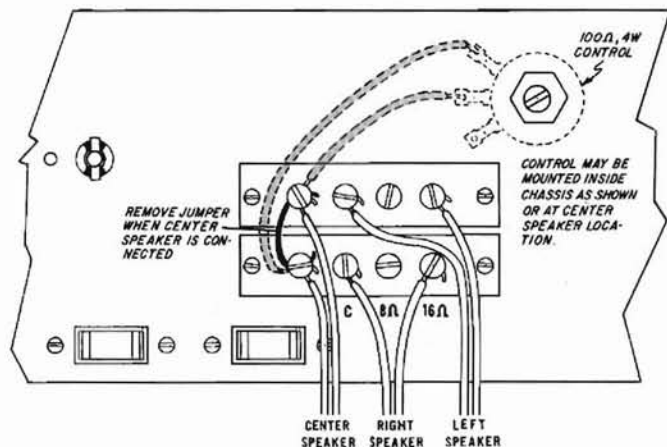

It is best that all the speakers should be identical types when using this arrangement. If this is done, the sound level at the center speaker will be comparable with that of the stereo speakers. The volume control will reduce the level of the extra speaker. It can be used to reduce the level of this speaker to zero, and then the stereo speakers will function in their normal way.

If the control is not added, and it is desired to cut out the center speaker to restore normal stereo operation, this can be done by re-installing the jumper on the back panel. This can also be done by adding a switch to connect together the two leads to the center loudspeaker. This switch can be located any place which is convenient — at the speaker location, or at the amplifier. When the switch is closed, there will be no sound from the center speaker, and normal stereo reproduction will be obtained.

The center speaker should be phased properly. This can be done by listening to the smoothness of transition of sound between speakers while moving back and forth between them. If there are sudden jumps in localization of the sound, the two wires to the center speaker should be interchanged. Correct phasing should provide a smooth change in location of sound from side speakers to center speaker. If the center speaker is used remotely, phasing is not important.

NOTE: At any time that the center speaker is removed, the jumper between the screw terminals *must* be reinstated. If neither the jumper nor center speaker is connected, the resulting sound will have no monophonic components. There will be no sound with monophonic sources and unrealistic effects with stereo sources.

USING HEADPHONES WITH THE SCA-35

Headphones made for high fidelity usage are generally of the low impedance type, designed to be connected to the loudspeaker terminals of the amplifier. These can, of course, be used directly with the SCA-35 in accordance with the instructions of the headphone manufacturer.

In addition, for ease of headphone connection and use, a hole for a headphone jack is available on the back panel of the SCA-35. A jack of the Switchcraft type 12B, or equivalent, can be mounted in this hole. A type 290 plug, or equivalent, should be used with the 12B jack. If the headphones are supplied with a different type of plug, the proper jack should be obtained for the plug used.

The diagram below shows the best method of connection to the headphone jack. The 100 ohm, 1/2 watt, resistors drop the signal to the level which is required for headphones. If there is inadequate level after installation, these resistors can be reduced to 47 ohms, or to any specific value recommended by the manufacturer of the headphones. Some headphones have the resistors built in. Then it is not necessary to install them, and straight wires (insulated to avoid short circuits) should be connected in place of the resistors shown.

If it is desired to cut out the loudspeakers completely for headphone listening, the pictorial diagram shows how a double pole switch can be used to eliminate sound from the loudspeakers during headphone use. This switch can be mounted any place along the loudspeaker wires so that it can be kept in a convenient place if switching is required frequently.

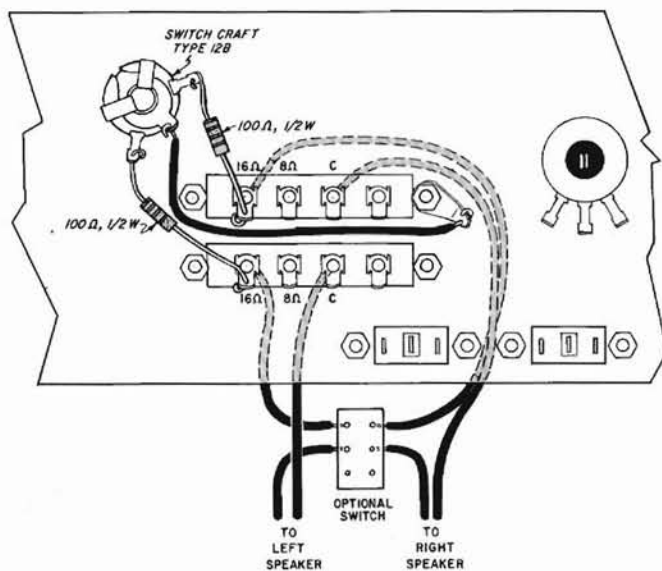

If, after the headphones are installed, it is found that the right and left sides are incorrect and the phones are not of a construction which can be reversed on the head, this can be most simply corrected by disconnecting the resistors from the two jack lugs and interchanging the connections.

TECHNICAL DESCRIPTION

The DYNA Stereo Control Amplifier, SCA-35, is a complete stereo preamplifier and stereo power amplifier combined on a single chassis with a single power supply. The SCA-35 uses new circuitry and new components in a unique arrangement which provides highest quality performance in a compact and moderately priced unit. Superficial examination of the circuit of the SCA-35 might indicate an apparently simple and conventional design. However, closer scrutiny will reveal an extremely sophisticated and carefully refined design.

There are four basic sections of the SCA-35: (1) the stereo preamplifier; (2) the dual tone control section; (3) the stereo power amplifiers, and (4) the power supply. Each of these utilizes novel circuitry with premium grade components conservatively operated. The four sections combine in an inter-relationship which develops the maximum potential of these components.

The Preamplifier

The preamplifier section of the SCA-35 is a printed circuit module in which a 12AX7 tube is used for each stereo channel. All low level inputs are fed to the input stages of these tubes via a portion of the selector switch. High and low level magnetic cartridges and crystal/ceramic cartridges are introduced to the input switch through a PEC (packaged electronic circuit). The switch also selects a tape head input. These low level signals are amplified through two stages (the two halves of the 12AX7). The amplification of this tube is increased almost to its theoretical maximum by the application of positive feedback from cathode to cathode.

A negative feedback loop containing the proper equalization circuits to shape the response of phono and tape head is carried around the 12AX7. Operating parameters are selected to enable this stage to carry signals at distortion levels below 0.1%. A 4 millivolt magnetic cartridge will produce one volt at 1000 cps at the output of this section.

The output of the 12AX7 is fed to another section of the selector switch, which at this point can also select higher level inputs such as radio and tape preamplifier.

The Tone Controls

Dual tone controls are used in a network which is completely passive; it has no distortion or noise. This network is also a PEC in which all components are encapsulated. Associated with the tone controls are the filter switch, the balance control, and the volume control. Signal levels to this section normally are about one volt (which is also the normal output of the preamplifier stage). However, the design is such that signals of any magnitude can be handled without possibility of overloading the power amplifier inputs.

The Power Amplifiers

Each power amplifier is on its individual printed circuit

module. These are truly unique circuits in which optimum use is made of the components.

The first stage is a pentode section of a 7199 tube. This is directly coupled to a cathodyne phase inverter. Negative dc feedback is taken from cathode to screen to stabilize the dc operating point of this pair. A positive feedback loop from cathode to cathode augments the amplification of the stage. The cathodyne inverter has the unusual advantage that its phase inversion capabilities are dependent solely on the values of its associated resistors. The accuracy of phase inversion is unaffected by tube aging and similar variations.

The phase inverter drives a pair of 6BQ5 output tubes. Careful investigation has determined the precise operating parameters for the output tubes and output transformer. The output transformer designed for the circuit (DYNACO Z-565) provides maximum linearity in this configuration. This transformer represents an advance in the state of the art as it permits the full power of the output tubes to be handled throughout the audio spectrum in a unit of very small size. It also permits a high order of feedback with complete stability of operation under all amplifier load conditions.

Contrary to traditional usage, a single cathode resistor is used for all four output tubes. This improves the performance of the output stage, but it makes it desirable to match the four output tubes. The output tubes supplied are carefully matched for this circuit.

The Power Supply

The SCA-35 is powered by a power transformer and full wave rectifiers using silicon diodes. Separate heater windings are included in the power transformer to provide means for individual hum adjustments on each stereo channel.

The power transformer is impregnated with an epoxy resin which serves the dual purpose of heat dissipation from the core and prevention of noise and vibration.

GENERAL WIRING PRACTICE

Assembly of the SCA-35 is exceptionally simple when compared to that of other similar kits. The circuit boards are supplied with all components mounted, and the remaining parts arranged on the chassis in an open, uncluttered way that makes wiring quick and easy. The construction of the SCA-35 should take no more than a few hours.

When you unpack the kit, check the components against the parts list first. You can identify unfamiliar components by matching them to parts illustrated in the pictorial diagrams supplied.

Have the proper tools at hand before beginning to build your kit. You will need a pencil-type soldering iron of 30- to 60-watt rating; long-nosed pliers; diagonal cutters; and a screwdriver. If you have a soldering gun, it should be used with care, especially when working on the circuit board, because of its higher than necessary heat output. Although not essential, a wire-cutting and stripping tool will help considerably; these are available for less than a dollar.

The only procedure involved in building a Dynakit which requires a bit of technique is soldering, and this is quite easy to master. There are four steps to making a good solder connection:

1. Make a good mechanical connection.
2. Heat both parts of the connection with the iron.
3. Apply solder to the connection until it melts and runs.
4. Allow the connection to cool undisturbed.

ALL SOLDERING MUST BE DONE WITH ROSIN CORE SOLDER.

There is no warranty on any equipment in which acid core solder has been used. Make sure that the solder you use is plainly marked "ROSIN CORE." Do not use cheap solder or solder of doubtful origin. Recommended solder is 60/40 (60% tin, 40% lead) rosin core.

Whenever one (1) wire is to be soldered to a connection, the instructions will indicate this by the symbol (S). When two (2) wires are to be soldered to a connection, the symbol (S-2) is shown; when three (3) wires are to be soldered, the symbol (S-3) appears, etc. There may be as many as five (5) wires to be soldered to a connection. If no symbol is shown, do not solder; further wiring will be made to that connection before soldering.

Components can be identified by comparison with the pictorial diagrams. Capacitors are individually marked. Resistors will be marked either with their values, or with the color code specified in the instructions. The first color is nearest the end of the resistor, and any fourth color band may be ignored.

A number of steps in the instructions begin, "Connect one end of a wire . . .", with the length of the wire specified. In each case, first cut a piece of wire to the correct length from the roll supplied with the kit, and then remove about $\frac{1}{4}$ " of insulation from each end before making the connection. The leads on components should be trimmed as they are used, the length chosen being that which permits a connection to be made from point to point without strain on terminals or components. The position of all wire leads should follow that shown in the pictorial diagram as closely as possible. Care must be exercised to see that uninsulated wires do not touch each other, and cannot do so through vibration or sagging, unless, of course, they are connected to the same point. It is especially important that uninsulated wires and component leads or terminals do not touch the chassis or bottom plate accidentally.

Check your work after each step, and, when you are satisfied that it has been correctly done, mark the space provided and go on to the next step. Examine the pictorial diagrams often; if you check your work methodically, your amplifier should work as soon as the wiring is complete.

One of the best ways to make a good mechanical connection is to bend a small hook in the end of a wire, and then to crimp this hook onto the terminal to be connected. The amount of bare wire exposed at the end need not be exactly $\frac{1}{4}$ -inch; however, if it is too long, there is danger of the excess touching another terminal or the chassis. There is no need to wrap the wire around the terminal more than one time, as this makes a connection that is much more difficult to remove if an error has been made.

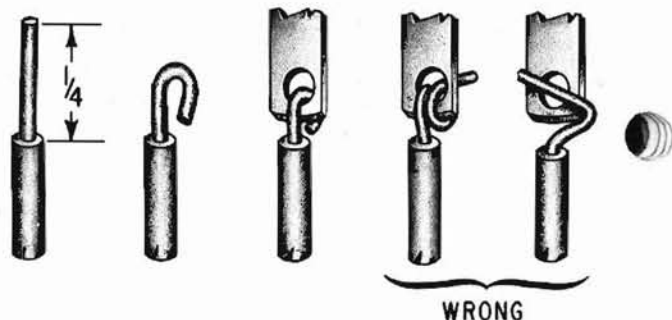

To transfer heat from the iron to the wire and terminal, the tip of the iron should be kept brightly tinned with solder. If this is properly done the first time the iron is used, the tinning may be maintained by wiping the tip with a cloth or sponge every few minutes while soldering. When correctly tinned, the tip will heat both parts of the con-

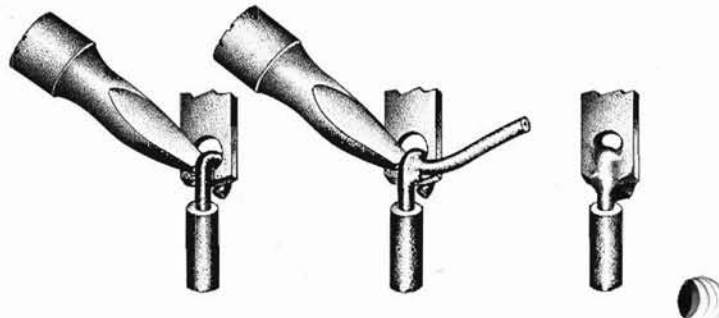

nection almost immediately. Solder should then be applied directly to the parts to be soldered, as shown in the middle illustration above, and both iron and solder removed as soon as the solder flows freely.



The circuit boards of the SCA-35 are supplied with all components (resistors and capacitors) already mounted and soldered in place. The circuit boards are connected to the other sections of the amplifier channels by soldering wires to eyelets on the boards. These eyelets, which are numbered for identification, are filled with solder already. To solder a wire to them, first "tin" the bared wire by heating it with the iron and flowing solder over it. The eyelet is then heated with the tip of the iron, and the end of the wire inserted as soon as the solder in the eyelet flows. A correctly made connection looks like the illustration at the right, above, which shows a smooth transition from eyelet to wire.

FRONT PANEL MECHANICAL ASSEMBLY

- 1(✓) Place the front panel before you so that its "wings" are facing you, with the rectangular switch cutouts at the bottom, as in the pictorial diagram. Refer to the pictorial diagram before and after each step to be sure that you are proceeding correctly. Install the pilot light socket at the extreme left end of the panel with a #4 screw inserted from the outside, and a lockwasher and nut from the inside (the side of the panel which is toward you). The #4 screws are the smallest size supplied with the kit.
- 2(✓) Install the treble control (marked 167504) next to the pilot light (see the pictorial diagram). Place a $\frac{3}{8}$ " lockwasher on the shaft before inserting the shaft through the panel, and secure it with a $\frac{3}{8}$ " nut. Before tightening the nut, see that the connecting lugs of the control are positioned as shown in the diagram.
- 3(✓) Install the bass control (167205) in the next hole. Place a $\frac{3}{8}$ " lockwasher on the shaft, insert the shaft, and secure it from the outside with a $\frac{3}{8}$ " nut. Before tightening the nut, observe the orientation of the connecting lugs shown on the pictorial diagram and see that the bass control is positioned correctly.
- 4(✓) Install the balance control (167754) in the next hole using $\frac{3}{8}$ " hardware and positioning the connecting lugs as shown in the pictorial diagram.
- 5(✓) Install the volume control (177254) in the next hole with $\frac{3}{8}$ " hardware, positioning the connecting lugs as shown in the pictorial diagram.
- 6(✓) The power switch is the only one of the slide switches with only two connecting lugs. Install the power switch from the inside, in the rectangular cut-out nearest the pilot light socket so that its connecting lugs are in the position shown in the pictorial diagram. The slide switch mounting holes are threaded and do not require lockwashers and nuts. Install the power switch with two #4 screws inserted from the front side of the panel.
- 7(✓) The three remaining slide switches are identical. They should be mounted in the three rectangular cutouts—their orientation is not important.

NOTE: The selector switch should not be installed until later, when called for in the instructions.

FRONT PANEL WIRING

These instructions frequently specify that you twist together some wires. This twisting should not be done too tightly or the wire may cut through the insulation. The twist is sufficiently tight as long as the wires are neat and will remain together; there is no need for excessive twisting.

- 1(✓) Twist together two 9" green wires. Connect one end of one wire to pilot light socket lug #1 (S). Connect the same end of the other wire to pilot light socket lug #2 (S). The opposite ends of these wires will later be connected to the main chassis assembly.
- 2(✓) Twist together a 12 $\frac{1}{2}$ " and a 15" black wire so that they are even at one end. Connect one of the matching ends to power switch lug #1. Connect the same end of the other wire to power switch lug #2.
- 3(✓) Cut each lead of the .02 mfd disc capacitor to $\frac{1}{2}$ ". Connect one lead of the .02 mfd disc capacitor to power switch lug #1 (S-2). Connect the other lead to power switch lug #2 (S-2).

- 4(✓) The numbering of the lugs on the controls is shown on the pictorial diagram. Connect one end of a 2 $\frac{1}{2}$ " red wire to treble control lug #5 (S). Connect the other end to bass control lug #5.
- 5(✓) Connect one end of a 2 $\frac{1}{2}$ " green wire to treble control lug #2 (S). Connect the other end to bass control lug #2.
- 6(✓) Connect one end of a 2" red wire to bass control lug #5. Connect the other end to balance control lug #6(S).
- 7(✓) Connect one end of a 2" green wire to bass control lug #2. Connect the other end to balance control lug #1 (S).
- 8(✓) Twist together a 5" black and a 5" red wire. Connect one end of the black wire to balance control lug #4. Connect the same end of the red wire to balance control lug #5 (S).
- 9(✓) Observe, on the pictorial diagram, the manner in which the PEC-555002 tone control modules are wired to the bass, treble, and volume controls. Begin by carefully cutting the leads of *one* of the circuit modules exactly to the following lengths; slip black insulating sleeving on the leads as specified. The PEC modules should be connected while in their final position.

Lead #1	2"	1 $\frac{3}{4}$ " of sleeving
#2	2"	1 $\frac{3}{4}$ " of sleeving
#3	1 $\frac{1}{4}$ "	1" of sleeving
#4	1 $\frac{1}{4}$ "	1" of sleeving
#5	1 $\frac{1}{4}$ "	1" of sleeving
#6	2"	1 $\frac{3}{4}$ " of sleeving
#7	DO NOT CUT	3 $\frac{3}{4}$ " of sleeving

The PEC modules should be connected as shown in the picture. Place the first module flat against the bass control so that the numbers marked on it are visible; this module connects to terminals nearest to the front panel. After all connections are made to the first module, the second module will be placed flat against it in the same position, and its leads connected to the terminals on the rear sections of the controls. The complete assembly should look like the diagram.

- 10(✓) Connect PEC lead #1 to treble control lug #4 (S).
- 11(✓) Connect PEC lead #2 to treble control lug #6 (S).
- 12(✓) Connect PEC lead #3 to bass control lug #4 (S).
- 13(✓) Connect PEC lead #4 to bass control lug #5 (S-3).
- 14(✓) Connect PEC lead #5 to bass control lug #6 (S).
- 15(✓) Connect PEC lead #6 to balance control lug #4.
- 16(✓) Connect PEC lead #7 to volume control lug #5 (S).
- 17(✓) The remaining PEC-555002 will now be connected. First, carefully cut its leads exactly to the following lengths and slip the specified lengths of black insulating sleeving on the leads which require it.

Lead #1	2"	1 $\frac{3}{4}$ " of sleeving
#2	1 $\frac{5}{8}$ "	} No sleeving required
#3	$\frac{7}{8}$ "	
#4	$\frac{7}{8}$ "	
#5	$\frac{7}{8}$ "	
#6	1 $\frac{1}{2}$ "	
#7	DO NOT CUT	3 $\frac{3}{4}$ " of sleeving

- 18(✓) Connect PEC lead #1 to treble control lug #1 (S).
- 19(✓) Connect PEC lead #2 to treble control lug #3 (S).
- 20(✓) Connect PEC lead #3 to bass control lug #1 (S).
- 21(✓) Connect PEC lead #4 to bass control lug #2 (S-3).
- 22(✓) Connect PEC lead #5 to bass control lug #3 (S).
- 23(✓) Connect PEC lead #6 to balance control lug #3.
- 24(✓) Connect PEC lead #7 to volume control lug #2 (S).
- 25(✓) Connect one lead of a 10 nf capacitor to filter switch lug #1. Connect other lead to filter switch lug #2.
- 26(✓) Connect one lead of the other 10 nf capacitor to filter switch lug #4. Connect the other lead to filter switch lug #5.
- 27(✓) Connect one lead of a 3.3 nf capacitor to filter switch lug #3 (S). Connect the other lead to balance control lug #4.
- 28(✓) Connect one lead of another 3.3 nf capacitor to filter switch lug #6 (S). Connect the other lead to balance control lug #3.
- 29(✓) Connect one end of a 6½" green wire to filter switch lug #4 (S-2). Connect the other end to volume control lug #3 (S).
- 30(✓) Connect one end of a 6½" red wire to filter switch lug #1 (S-2). Connect the other end to volume control lug #6 (S).
- 31(✓) Connect one end of an 8½" green wire to filter switch lug #5 (S-2). Connect the other end to stereo-mono switch lug #4. Note the manner in which this lead is positioned in the diagram.
- 32(✓) Connect one end of a 9" red wire to filter switch lug #2 (S-2). Connect the other end to stereo-mono switch lug #5, positioning this lead above the switches as shown in the pictorial diagram.
- 33(✓) Twist together a 9" green and a 9" black wire. Connect one end of the black wire to balance control lug #3. Connect the same end of the green wire to balance control lug #2 (S).
- 34(✓) Connect one end of a 3½" black wire to balance control lug #3 (S-4). Connect the other end to volume control lug #1.
- 35(✓) Connect one end of a 3½" black wire to balance control lug #4 (S-4). Connect the other end to volume control lug #4.
- 36(✓) Connect one lead of an 18,000 ohm (brown-gray-orange) resistor to loudness switch lug #1. Connect the other lead to volume control lug #4 (S-2).
- 37(✓) Connect one lead of the other 18,000 ohm (brown-gray-orange) resistor to loudness switch lug #4. Connect other lead to volume control lug #1 (S-2).
- 38(✓) Connect one lead of a 22 nf tubular capacitor to loudness switch lug #1 (S-2). Connect the other lead to volume control lug #8.
- 39(✓) Cut one lead of the other 22 nf capacitor to 1". Place a ¾" piece of insulating sleeving on this lead and connect it to loudness switch lug #4 (S-2). Connect the other lead to volume control lug #7.
- 40(✓) Connect one end of a 2" red wire to loudness switch lug #2 (S). Connect the other end to volume control lug #8 (S-2).
- 41(✓) Connect one end of a 2½" green wire to loudness switch lug #5 (S). Connect the other end to volume control lug #7 (S-2).
- 42(✓) Connect one lead of a 10,000 ohm (brown-black-orange) resistor to stereo-mono switch lug #1. Connect other lead to stereo-mono switch lug #4 (S-2).
- 43(✓) Connect one lead of the other 10,000 ohm (brown-black-orange) resistor to stereo-mono switch lug #3. Connect the other lead to stereo-mono switch lug #5 (S-2).
- 44(✓) Connect one end of a 5" green wire to stereo-mono switch lug #1 (S-2).
- 45(✓) Connect one end of a 4" red wire to stereo-mono switch lug #3 (S-2).

This completes the front panel sub-assembly. Every connection on the front panel should have been soldered; check to see that this has been done. The hole in the front panel which is still empty will later be filled by the selector switch. Set aside the front panel sub-assembly for the present time.

REAR PANEL MECHANICAL ASSEMBLY

- 1(✓) Place the rear panel so that its "wings" face you. Four identical input socket strips are supplied, each with four input sockets on it. Mount one of these in each of the cutouts as shown in the pictorial diagram; these strips are mounted from the *inside*. Use a #4 screw, inserted from the *outside*, a lockwasher and nut for each mounting hole. NOTE: When mounting the two strips in the two *large* cutouts, center the strips so that the metal portions do not touch the chassis.
- 2(✓) There are two identical output terminal strips, each with four screw terminals. Mount one of these in each of the two cutouts provided at the locations shown on the pictorial diagram; these strips mount from the *outside*. Be sure to mount the ground lug over the screw at the place indicated on the pictorial diagram instead of a lockwasher. Use #4 hardware for each hole.
- 3(✓) There are two AC convenience outlets. Mount one of these in each of the cutouts provided, as shown in the pictorial diagram. The outlets mount from the *inside*. Use #4 hardware.
- 4(✓) Mount the fuse holder. The rubber washer provided should be fitted against the shoulder of the fuse holder before it is inserted in its hole, from the *outside* of the panel. While pressing the fuse holder against the panel, use the special ⅜" circular nut to fasten it in place. Note position of connecting lug B.
- 5(✓) Insert the rubber grommet for the line cord in its hole.
- 6(✓) The two hum controls are "snap-in" types. Observe the position of the locating lug on each control which fits a hole in the chassis. Snap them in place by pressing them firmly into the mounting holes on the panel from the *inside*.

REAR PANEL WIRING

- 1(✓) There are a total of sixteen input sockets on the rear panel; the center (long) lug of each socket has a number, shown in the pictorial diagram. Connect one end of a 1½" black wire to the pair of *short* lugs between sockets #1 and #2. Connect the other end to the pair of *short* lugs between sockets #3 and #4 (S).
- 2(✓) Connect another 1½" black wire to the *short* lugs between #5 and #6 (S). Connect the other end to the *short* lugs between #7 and #8.
- 3(✓) Connect another 1½" black wire to the *short* lugs between #9 and #10, and the other end to the *short* lugs between #11 and #12 (S).
- 4(✓) Connect one more 1½" black wire to the *short* lugs between #13 and #14 (S); and the other end to the *short* lugs between #15 and #16.
- 5(✓) Connect one end of a 1½" black wire to the *short* lugs between #7 and #8 (S-2). Connect the other end to the *short* lugs between #15 and #16.
- 6(✓) Connect one end of a 2¾" black wire to the *short* lugs between #15 and #16 (S-3). The other end remains free for the present time.
- 7(✓) Note the method of connecting the PEC-555003 input circuit module to the long lugs of sockets #1, #2, #3 and #4, and to the *short* lugs between sockets #1 and #2. Connect lead 1 to socket #1, lead 0 to the *short* lugs between #1 and #2, lead 2 to socket #2, lead 3 to socket #3 (S), and lead 4 to socket #4 (S).
- 8(✓) Connect the other PEC-555003 input circuit module to the following lugs: lead 1 to socket #9, lead 0 to the *short* lugs between #9 and #10, lead 2 to socket #10, lead 3 to socket #11 (S), and lead 4 to socket #12 (S).
- 9(✓) A length of flat, 4-conductor cable has been supplied with the kit. Cut the cable into two pieces, one 10" long and the other 12" long. Carefully separate the four wires at each end of each piece for about 1½", and strip ¼" of insulation from all 16 ends. Connect one end of the 10" piece to the long lugs of the input sockets in the following manner:
 - Brown to socket #5 (S).
 - Red to socket #6 (S).
 - Orange to socket #7 (S).
 - Yellow to socket #8 (S).The opposite ends are not to be connected until later.
- 10(✓) Connect one end of the 12" piece of flat cable to the long lugs of the input sockets as follows:
 - Brown to socket #13 (S).
 - Red to socket #14 (S).
 - Orange to socket #15 (S).
 - Yellow to socket #16 (S).The opposite ends are not to be connected until later.
- 11(✓) Connect one end of a 10½" red wire to lug #10 (S-2). Bend the free end of this wire to mark it so that it can be identified later when it is twisted together with other wires.
- 12(✓) Connect an end of a 10½" red wire to lug #9 (S-2).
- 13(✓) Connect one end of a 12" black wire to the pair of *short* lugs between sockets #9 and #10 (S-3). Twist this wire together with the two red wires connected to lugs #9 and #10.
- 14(✓) Connect one end of an 8¾" green wire to lug #2 (S-2). Bend the free end of this wire to mark it.
- 15(✓) Connect one end of an 8½" green wire to lug #1 (S-2).
- 16(✓) Connect one end of an 11½" black wire to the pair of *short* lugs between sockets #1 and #2 (S-3). Twist this wire together with the green wires connected to lugs #1 and #2.
- 17(✓) The lugs on the rear of the output screw terminal strips are numbered from #1 to #8, as shown on the pictorial diagram. Connect one end of a 1½" bare wire to the ground lug on the mounting screw of the upper output terminal strip. Connect the other end to output lug #8.
- 18(✓) Connect one end of a 4" black wire to the ground lug on the mounting screw of the upper output terminal strip (S-2).
- 19(✓) Connect one end of a 2" bare wire to output lug #7 (S). Feed the other end of the wire through the hole in output lug #3 (S) and connect it to output lug #4 (S). On the *outside* of the back panel connect a piece of bare wire across the two screw terminals which correspond to #4 and #8 output lugs. (The amplifier will furnish a signal to a derived center channel speaker if this wire is removed and a loudspeaker connected in its place. Instructions for this connection are covered in another section.)
- 20(✓) Connect one end of a 1½" black wire to lug #2 of AC outlet A. Connect the other end to lug #1 of AC outlet B.
- 21(✓) Connect one end of a 1" black wire to lug #2 of AC outlet B. Connect the other end to terminal B of the fuse holder (S).
- 22(✓) Connect one end of a 2" black wire to lug #2 of the *left* hum control (S). Connect the other end to lug #2 of the *right* hum control.
- 23(✓) Connect one end of a 10" black wire to lug #2 of the *right* hum control (S-2).
- 24(✓) Twist together two 11" green wires. Connect one end of one green wire to lug #1 of the *left* hum control (S). Connect the same end of the other wire to lug #3 of the *left* hum control (S).
- 25(✓) Twist together two 11" green wires. Connect one end of one green wire to lug #1 of the *right* hum control (S). Connect the same end of the other wire to lug #3 of the *right* hum control (S).
- 26() Insert a sheet-metal screw in the hole marked "GRND" above the input sockets, from the *outside* of the chassis. This will furnish a connection point for an external ground wire when installing the amplifier.

This completes the first portion of work on the rear panel sub-assembly. Note that there are several non-soldered connections. Set aside this assembly for the present.

MAIN CHASSIS MECHANICAL ASSEMBLY

- 1(✓) Pass the leads of one of the output transformers Z-565 through the two holes provided nearest the *front* of the chassis (see the pictorial diagram for the correct location). The leads of the transformer are in two groups: the orange, black, and yellow leads which pass through the rear chassis hole; and five other leads which pass through the front hole. Before attaching the transformer to the chassis with four sets of #8 hardware (the largest size supplied with the kit), mount a 5-lug terminal strip and the cable clamp under two of the transformer mounting screws as indicated on the pictorial diagram. Insert the lockwasher between the nut and cable clamp, and between the nut and terminal strip mounting lug, and under all the other nuts. Do not tighten the nut under the cable clamp.
 - 2(✓) Pass the leads of the power transformer PA-774 through the two holes provided at the rear corner of the chassis, observing the lead orientation shown in the pictorial diagram. Mount the transformer with #8 hardware, and install a 5-lug terminal strip on one of the mounting screws as shown in the diagram.
- NOTE: Instructions for PB-028, a 120/240 volt transformer for use outside the United States, will be found at the end of the regular assembly instructions.
- 3(✓) Use #8 hardware to mount the other Z-565 output transformer at the rear of the chassis, in the position indicated on the pictorial diagram. The orange, black and yellow leads should pass through the hole closest to the rear of the chassis, and the remaining leads through the other hole.
 - 4(✓) Before mounting the two PC-10 circuit boards install the four sockets supplied for V-5, V-6, V-7 and V-8 on the *top* of the boards (the side on which the components are mounted). Note that the pairs of sockets on each board do not face in the same direction. Refer to the pictorial for the correct orientation. Use #4 hardware; insert the screws from the *bottom* of the circuit board and install the lockwasher and nut from the *top*.
 - 5(✓) Mount the two PC-10 circuit boards from the *bottom* of the chassis, as shown on the pictorial diagram, using four sets of #4 hardware to mount each board. Note their orientation, and leave air space between the boards.
 - 6(✓) Mount the PC-11 preamplifier circuit board in the position shown on the pictorial diagram, using #4 hardware, from the *bottom* of the chassis.
 - 7(✓) Install the two filter capacitor mounting wafers from the *bottom* of the chassis in the cutouts provided at the rear corner, using two sets of #4 hardware to secure each wafer.
 - 8(✓) The four-section filter capacitor (marked 60/40/20/100) mounts in the wafer nearest to the center of the chassis; note the position of the symbols stamped on the underside of the capacitor, as shown on the pictorial diagram. The capacitor *must* be mounted in this position. Insert the mounting lugs in the slots provided, from the top of the chassis; check the diagram to see that the markings are correctly located. Then, twist each of the mounting lugs $\frac{1}{4}$ -turn with pliers, while holding the capacitor firmly against the wafer from above.

- 9(✓) The same procedure as in the preceding step is used to install the two-section filter capacitor (marked 50/50) in the remaining wafer. Note that the symbols stamped in the underside of the capacitor are differently positioned than for the other filter capacitor. Mount the two-section filter capacitor by inserting and twisting its mounting lugs.

MAIN CHASSIS WIRING

The leads of the transformers may often be somewhat longer than is necessary to make the connections required with proper lead positioning. In each case where a transformer lead is to be connected, first run the lead to its connection point, following the path shown in the pictorial diagram. After cutting the proper length of the lead, strip $\frac{1}{4}$ " of the insulation from the end of the lead, and "tin" the end by heating it and applying solder to it; this prevents fraying strands and ensures a more secure mechanical bond before soldering.

- 1(✓) Connect the red lead from the *rear* output transformer to lug #4 (square symbol) of the four-section filter capacitor. See pictorial for wire position.
 - 2(✓) Connect the red lead from the *front* output transformer to lug #4 (square symbol) of the four-section filter capacitor. See pictorial for wire position.
 - 3(✓) Twist together the blue-and-white and green-and-white leads from the output transformer nearest to the *front* of the chassis. Connect the blue-and-white lead to pin #7 of V-7 (S). Connect the green-and-white lead to pin #9 of V-7 (S).
 - 4(✓) Twist together the blue and green leads from the output transformer nearest to the *front* of the chassis. Connect the blue lead to pin #7 of V-8 (S). Connect the green lead to pin #9 of V-8.
 - 5(✓) Twist together the blue-and-white and green-and-white leads from the output transformer nearest to the *rear* of the chassis. Connect the blue-and-white lead to pin #7 of V-5 (S). Connect the green-and-white lead to pin #9 of V-5 (S).
 - 6(✓) Twist together the blue and green leads of the output transformer nearest to the *rear* of the chassis. Connect the blue lead to pin #7 of V-6 (S). Connect the green lead to pin #9 of V-6.
 - 7(✓) Twist together the two red leads from the power transformer PA-774. Connect either one of the red leads to lug #4 of terminal strip TS-1.
 - 8(✓) Connect the other red power transformer lead to lug #5 of terminal strip TS-1.
 - 9(✓) Connect the red-and-yellow power transformer lead to mounting lug A of the four-section filter capacitor.
 - 10(✓) Twist together the brown and brown-and-white leads from the power transformer. Pass the leads under the cable clamp, and connect the brown lead to lug #1 of terminal strip TS-2. Connect the brown-and-white lead to lug #2 of TS-2.
- NOTE: These transformer leads should be inserted into the eyelet that holds the terminal to the strip, thereby providing more space on the lug for the other wires to be connected.
- 11(✓) Twist together the green and green-and-white leads from the power transformer. Pass these leads under the cable clamp, and connect the green lead to lug

#4 of terminal strip TS-2. Connect the green-and-white lead to lug #5 of TS-2.

NOTE: These transformer leads should be inserted into the eyelet that holds the terminal to the strip, thereby providing more space on the lug for the other wires to be connected.

- 12(✓) The silicon rectifier diodes supplied with the kit may be any of the three types shown in the illustration; although different in appearance, they are electrically equivalent. Connect the *cathode* (or plus) lead of one of the rectifier diodes to lug #2 of terminal strip TS-1. Connect the other lead of the diode to lug #4 of terminal strip TS-1 (S-2).



IMPORTANT: Arrange the diode leads exactly as shown in the pictorial diagram. When soldering, hold pliers on the lead between the diode body and the solder connection to avoid application of excessive heat to the diode.

- 13(✓) Connect the *cathode* (or plus) lead of the second diode to lug #2 of terminal strip TS-1. Connect the other lead to lug #5 of terminal strip TS-1 (S-2).
- 14(✓) Connect one end of a 7" red wire to lug #2 of the terminal strip TS-1 (S-3). Use caution to avoid excessive heating of the diodes. Connect the other end to lug #3 (semi-circle symbol) of the four-section filter capacitor.
- 15(✓) Connect one lead of the 50 ohm, 5 watt resistor to lug #3 (semi-circle symbol) of the four-section filter capacitor (S-2). Connect the other lead to lug #4 (square symbol) of the same capacitor.
- 16(✓) Connect one lead of a 2200 ohm (red-red-red) 1 watt resistor to lug #4 (square symbol) of the four-section filter capacitor (S-4). Connect the other lead to lug #1 (triangle symbol) of the same capacitor.
- 17(✓) Connect one lead of the other 2200 ohm (red-red-red) 1 watt resistor to lug #1 (triangle symbol) of the four-section filter capacitor (S-2). Connect the other lead to lug #2 (semi-circle symbol) of the two-section filter capacitor.
- 18(✓) Connect one end of a 6½" red wire to lug #2 (semi-circle symbol) of the two-section filter capacitor. Connect the other end to eyelet #5 of the rear PC-10 circuit board (S).
- 19(✓) Connect one lead of a 22,000 ohm (red-red-orange) ½ watt resistor to lug #2 (semi-circle symbol) of the two-section filter capacitor (S-3). Connect the other lead to lug #1 (triangle symbol) of the same capacitor.
- 20(✓) Connect one end of a 6½" red wire to lug #1 (triangle symbol) of the two-section filter capacitor (S-2). Connect the other end to eyelet #12 on the PC-11 circuit board (S).
- 21(✓) Connect one lead of the 95 ohm, 5 watt resistor to mounting lug B of the four-section filter capacitor. Connect the other lead to lug #2 (no symbol) of the same capacitor.
- 22(✓) Connect one end of a 2" black wire to mounting lug B of the four-section filter capacitor (S-2). Connect the other end to mounting lug D of the two-section filter capacitor.

- 23(✓) Connect one end of a 6½" black wire to mounting lug D of the two-section filter capacitor (S-2). Connect the other end to eyelet #4 on the PC-11 circuit board (S).
- 24(✓) Connect one end of a 2½" red wire to eyelet #5 on the rear PC-10 circuit board (S-2). Note one wire is already connected; reheat the eyelet and insert the second wire. Connect the other end to eyelet #5 on the front PC-10 circuit board (S).
- 25(✓) Connect one end of a 4½" black wire to mounting lug C of the four-section filter capacitor. Connect the other end to eyelet #6 of the rear PC-10 circuit board (S).
- 26(✓) Connect one end of a 6½" black wire to mounting lug C of the four-section filter capacitor (S-2). Connect the other end to eyelet #6 on the front PC-10 circuit board (S).
- 27(✓) Connect one end of a 1¼" red wire to pin #3 of V-7 (S). Connect the other end to pin #3 of V-8.
- 28(✓) Connect one end of a 2½" red wire to pin #3 of V-8 (S-2). Connect the other end to pin #3 of V-6.
- 29(✓) Connect one end of a 1¼" red wire to pin #3 of V-6 (S-2). Connect the other end to pin #3 of V-5.
- 30(✓) Connect one end of a 7" red wire to pin #3 of V-5 (S-2). Connect the other end to lug #2 (no symbol) of the four-section filter capacitor.
- 31(✓) Connect one end of a 1¼" green wire to pin #2 of V-7 of the front PC-10 (S). Connect the other end to eyelet #9 (S).
- 32(✓) Connect one end of a 1¼" green wire to pin #2 of V-8 of the front PC-10 (S). Connect the other end to eyelet #8 (S).
- 33(✓) Connect one end of a 1¼" green wire to pin #2 of V-5 of the rear PC-10 (S). Connect the other end to eyelet #9 (S).
- 34(✓) Connect one end of a 1¼" green wire to pin #2 of V-6 of the rear PC-10 (S). Connect the other end to eyelet #8 (S).
- 35(✓) Connect one end of a 1½" green wire to pin #9 of V-8 of the front PC-10 (S-2). Connect the other end to eyelet #11 (S).
- 36(✓) Connect one end of a 1½" green wire to pin #9 of V-6 of the rear PC-10 (S-2). Connect the other end to eyelet #11 (S).
- 37(✓) Connect one end of a 4½" green wire to eyelet #2 of front PC-10 (S). Connect the other end to eyelet #10 (S).
- 38(✓) Connect one end of a 4½" green wire to eyelet #2 of rear PC-10 (S). Connect the other end to eyelet #10 (S).
- 39(✓) Twist together a pair of black and green wires, each 3" long. Connect one end of the black wire to eyelet #3 on the rear PC-10 (S). Connect the same end of the green wire to eyelet #4 on the rear PC-10 (S). Connect the other end of the black wire to pin #5 of V-5. Connect the remaining end of the green wire to pin #4 of V-5.
- 40(✓) Twist together a pair of black and green wires, each 2½" long. Connect one end of the black wire to pin #5 of V-5 (S-2). Connect the same end of the green wire to pin #4 of V-5 (S-2). Connect the other end of the black wire to pin #5 of V-6, and the other end of the green wire to pin #4 of V-6.

FINAL ASSEMBLY

- 41 (✓) Twist together a pair of green and black wires, each 2½" long. Connect one end of the black wire to lug #1 of terminal strip TS-2; connect the other end to pin #5 of V-6 (S-2). Connect one end of the green wire to lug #2 of TS-2. Connect the other end of the green wire to pin #4 of V-6 (S-2).
- 42 (✓) Twist together a pair of green and black wires, each 10½" long. Connect one end of the black wire to eyelet #9 on PC-11 (S). Connect the same end of the green wire to eyelet #10 on PC-11 (S). Connect the other end of the black wire to lug #1 of terminal strip TS-2. Connect the other end of the green wire to lug #2 of TS-2.
- 43 (✓) Twist together a pair of black and green wires, each 3" long. Connect one end of the black wire to eyelet #3 on the front PC-10 (S). Connect the same end of the green wire to eyelet #4 on the front PC-10 (S). Connect the other end of the black wire to pin #5 of V-7. Connect the other end of the green wire to pin #4 of V-7.
- 44 (✓) Twist together a pair of black and green wires, each 2½" long. Connect one end of the black wire to pin #5 of V-7 (S-2). Connect the same end of the green wire to pin #4 of V-7 (S-2). Connect the other end of the black wire to pin #5 of V-8, and the other end of the green wire to pin #4 of V-8.
- 45 (✓) Twist together a pair of green and black wires, each 3" long. Connect one end of the black wire to lug #4 of terminal strip TS-2. Connect the same end of the green wire to lug #5 of TS-2. Connect the other end of the black wire to pin #5 of V-8 (S-2). Connect the remaining end of the green wire to pin #4 of V-8 (S-2).
- 46 (✓) Twist together a pair of green and black wires each 12" long. Connect one end of the black wire to eyelet #15 on PC-11 (S). Connect the same end of the green wire to eyelet #13 on PC-11 (S). Connect the other end of the black wire to lug #4 of terminal strip TS-2. Connect the remaining end of the green wire to lug #5 of TS-2.

WIRING TO THE PC-11 CIRCUIT BOARD

The following wires are all to be connected from the top of the PC-11 preamplifier circuit board to the selector switch. To make the wiring to the selector switch easier when it is done later in the assembly process, the wires are connected to the circuit board now. The pictorial diagram shows exactly which wires are connected to each of the eyelets. Insert the wires from the top, and solder the wires in place by heating the eyelets from below the board, while checking the eyelet numbers to be sure that they have been inserted in the proper eyelets.

	LENGTH	COLOR	EYELET
1 (✓)	1½"	red	#16
2 (✓)	2"	red	#17
3 (✓)	2¾"	red	#14
4 (✓)	1¾"	red	#19
5 (✓)	4"	red	#20
6 (✓)	5"	black	#5
7 (✓)	1¾"	green	#2
8 (✓)	4"	green	#3
9 (✓)	5¼"	black	#1
10 (✓)	1½"	green	#8
11 (✓)	2¾"	green	#11
12 (✓)	2"	green	#7

The top of the selector switch is marked with a red dot. With the shaft pointing toward you, and the dot at the top, a locating lug protrudes from the left front. The pictorial diagram shows the terminal numbers, and identifies the wafers as A (front) and B (rear). *Whenever a terminal location has separate lugs on the front and back of the wafer, be sure you solder each wire to both lugs.*

- 1 (✓) Connect one lead of a 1.5 megohm (brown-green-green) resistor to selector switch lug B-2. Connect the other lead to lug B-5.
- 2 (✓) Connect one lead of a 3.3 nf capacitor to selector switch lug B-5 (S-2). Connect the other lead to lug B-2.
- 3 (✓) Connect one lead of the other 1.5 megohm (brown-green-green) resistor to selector switch lug A-2. Connect the other lead to lug A-5.
- 4 (✓) Connect one lead of a 3.3 nf capacitor to selector switch lug A-5 (S-2). Connect the other lead to lug A-2.
- 5 (✓) Attach the front panel sub-assembly to the main chassis with four sheet metal screws, using two on each side in the holes provided. Note that all but the two wires from the stereo-mono switch pass under the chassis.
- 6 (✓) Carefully install the selector switch on the front panel as shown in the pictorial diagram. Place a ⅜" lockwasher on the bushing at the front of the switch, insert the switch in the hole provided on the front panel and rotate it so that the red dot which indicates the top of the switch is toward the top of the panel. In this position the locating lug on the front of the switch should engage the small hole in the front panel. Fasten the switch securely in place with a ⅜" nut.
- 7 (✓) Connect the red wire from eyelet #16 on the PC-11 circuit board to lug A-7 on the selector switch (S).
- 8 (✓) Connect the red wire from eyelet #17 on the PC-11 circuit board to lug A-9 on the selector switch (S).
- 9 (✓) Connect the red wire from eyelet #19 to lug A-6 (S).
- 10 (✓) Position the black wire from eyelet #5 over to the red wire from eyelet #20 and twist them together. Position the twisted pair in front of selector switch wafer A (between the wafer and the front flange of the main chassis). Connect the red wire to lug A-4 (S). Connect the black wire to lug A-3 (S).
- 11 (✓) Connect the red wire from eyelet #14 to lug A-2 (S-3).
- 12 (✓) Connect the green wire from eyelet #8 to lug B-7 (S).
- 13 (✓) Connect the green wire from eyelet #7 to lug B-9 (S).
- 14 (✓) Connect the green wire from eyelet #2 to lug B-6 (S).
- 15 (✓) Position the black wire from eyelet #1 over to the green wire from eyelet #3 and twist them together. Position the twisted pair in front of selector switch wafer B (between wafers B and A, but close to B). Connect the green wire to lug B-4 (S). Connect the black wire to B-3 (S).
- 16 (✓) Connect the green wire from eyelet #11 to lug B-2 (S-3).
- 17 (✓) Connect the red wire from the stereo-mono switch to lug A-1.

- 18(✓) Connect the green wire from the stereo-mono switch to lug B-1.
- 19(✓) Connect the black wire of the red-and-black twisted pair from the balance control to eyelet #6 on the front PC-10 (S-2). This is the second wire connected to this eyelet. Connect the red wire of this pair to eyelet #7 (S).
- 20(✓) Connect the black wire of the green-and-black twisted pair from the balance control to eyelet #6 on the rear PC-10 (S-2). This is the second wire connected to this eyelet. Connect the green wire of this pair to eyelet #7 (S).
- 21(✓) Feed the twisted pair of green wires from the pilot light socket through the cable clamp. Connect one of these wires to lug #4 of terminal strip TS-2. Connect the other green wire to lug #5 of TS-2.
- 22(✓) Place the main chassis upside down so that the front panel faces you. Bring the rear panel sub-assembly close to the proper position (also upside down), but do not fasten in place at this time. Position the flat four conductor cables and the twisted three sets of wires from the input sockets on the top side of the chassis. All the other wires will be connected on the bottom of the chassis.
- 23(✓) Connect the black wire from the ground lugs between input sockets #15 and #16 to mounting lug A of the four-section filter capacitor (S-2).
- 24(✓) Connect the black wire from the ground lug on the output terminal strip mounting screw to lug #3 of terminal strip TS-1 (S).
- 25(✓) Connect one of the black power transformer (PA-774) leads to lug #1 of AC outlet B (S-2). Connect the other black power transformer lead to lug A on the fuse holder (S).
- NOTE: If using the 120/240 volt power transformer, PB-028, replace this step with the steps specified on Page 16.
- 26(✓) Connect the longer black wire of the pair from the power switch to lug #1 of AC outlet A. Connect the other black wire of this pair to lug #2 of AC outlet B (S-2). Position these twisted wires under the cable clamp.
- 27(✓) Cut the black, orange and yellow leads from the output transformer Z-565 nearest to the rear of the chassis to 3" each. Twist these together and connect the black lead to output lug #8. Connect the orange lead to lug #2 (S). Connect the yellow lead to lug #1.
- 28(✓) Connect one end of a 7½" green wire to output strip lug #1 (S-2). Connect the other end of this wire to eyelet #1 on the rear PC-10 (S).
- 29(✓) Twist together the black, orange and yellow leads from the output transformer nearest to the front of the chassis. Place these leads under the cable clamp. Connect the black lead to output strip lug #8 (S-3). Connect the orange lead to lug #6 (S). Connect the yellow lead to lug #5.
- 30(✓) Connect one end of a 9" red wire to output strip lug #5 (S-2). Connect the other end of this wire to eyelet #1 on the front PC-10 (S).
- 31(✓) Connect the black wire from lug #2 of the right hum control to lug #2 (no symbol) of the four-section filter capacitor (S-3). Place this wire against the rear panel.
- 32(✓) Connect one of the green wires from the left hum control to lug #1 of terminal strip TS-2 (S-4). Connect the other green wire to lug #2 of TS-2 (S-4). Position these wires under the cable clamp.
- 33(✓) Connect one of the green wires from the right hum control to lug #4 of terminal strip TS-2 (S-5). Connect the other green wire to lug #5 of TS-2 (S-5). Position these wires under the cable clamp. Now tighten the hardware holding the cable clamp.
- 34(✓) Attach the rear panel sub-assembly to the main chassis with four sheet-metal screws, using two on each side in the holes provided.
- 35(✓) Pass the line cord through the rubber grommet mounted in the rear panel, and push it through far enough to tie a knot 4" from the end. Tie the knot. Then, separate the two conductors of the line cord for 2". Cut ½" from one of them, and strip and tin the ends of both.
- 36(✓) Connect the shorter of the two line cord conductors to lug #2 of AC outlet A (S-2). Connect the longer conductor to lug #1 of AC outlet A (S-2). Now turn the chassis over.
- 37(✓) Twist together the two red wires from input sockets #9 and #10 and the black wire from the short lugs between them. Connect the red wire with the previously bent end to eyelet #18 on the PC-11 circuit board (S). (Note the correct wire position shown on the pictorial diagram.) Twist another turn of the black wire around the remaining red wire and connect the black wire to eyelet #5 on the PC-11 circuit board (S-2). This is the second wire connected to this eyelet. Connect the remaining red wire to lug A-8 of the selector switch (S). Position these wires from the rear panel against the main chassis.
- 38(✓) Twist together the two green wires from input sockets #1 and #2 and the black wire from the short lugs between them. Connect the green wire with the previously bent end to eyelet #6 on the PC-11 circuit board (S). (Note the correct wire position shown on the pictorial diagram.) Twist another turn of the black wire on the remaining green wire and connect the black wire to eyelet #1 on the PC-11 circuit board (S-2). This is the second wire connected to this eyelet. Connect the remaining green wire to lug B-8 of the selector switch (S). Position these wires from the rear panel against the main chassis.
- 39(✓) Connect the yellow wire from input socket #16 on the rear panel to lug A-1 of the selector switch (S-2).
- 40(✓) Connect the orange wire from input socket #15 to lug A-12 (S).
- 41(✓) Connect the red wire from input socket #14 to lug A-11 (S).
- 42(✓) Connect the brown wire from input socket #13 to lug A-10 (S).
- 43(✓) Connect the yellow wire from input socket #8 to lug B-1 (S-2).
- 44(✓) Connect the orange wire from input socket #7 to lug B-12 (S).
- 45(✓) Connect the red wire from input socket #6 to lug B-11 (S).
- 46(✓) Connect the brown wire from input socket #5 to lug B-10 (S).

This completes the wiring of the unit. DO NOT PLUG IN THE AC CORD UNTIL THE TUBES HAVE BEEN INSTALLED AND THE COVER AND BOTTOM PLATE ARE SECURELY IN PLACE.

PLACES TO DOUBLE-CHECK AFTER WIRING

Be sure that all mounting screws and nuts are tight.

Compare the wiring of each of the tube sockets to that shown in the pictorial diagram. All connections should be securely soldered, with enough space between connections to the tube socket connecting lugs so that there is no chance of an accidental short-circuit.

Compare the wiring to each lug of the filter capacitors to that shown in the pictorial diagram. Check carefully to see that all connections have been soldered, and that excess lead length has not caused any connection to short-circuit to the chassis.

Examine all connections with particular care, to be sure that none of them have solder blobs which project enough to touch the bottom plate when it is installed. Check the terminal strips and the filter capacitors in particular.

Check each lug on each of the controls on the front panel, to be sure that all of them have been soldered.

Check the twisted wires at the ends where they have been soldered to see that the insulation has not melted to cause a shorted condition. This will occur if too much heat has been applied when soldering these wires and they have been twisted too tightly. Pay particular attention to the leads going to pins #4 and #5 of tube sockets V-5, V-6, V-7 and V-8, and to lugs #1, #2, #4 and #5 of terminal strip TS-2.

The wires to the selector switch should be positioned as shown below. Note particularly the twisted pairs to lugs A3 and A4, and to lugs B3 and B4. These should be close to the front surface of each wafer.

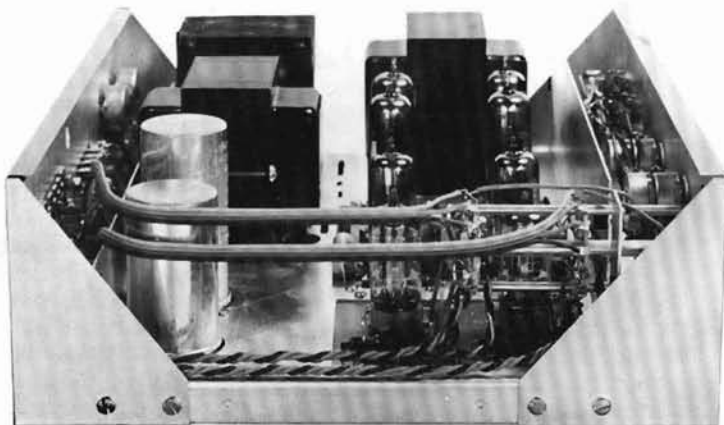

Turn the chassis upside down, and shake it vigorously to dislodge any wire clippings or bits of solder.

The tubes and the fuse should now be installed; the pictorial diagram shows the location of each tube. **IMPORTANT:** When inserting the tubes in their sockets for the first time, the socket should be supported from below the chassis to avoid strain on the circuit board because of the tight fit of new sockets. V-1 and V-2 are 12AX7/ECC-83 tubes and are installed in PC-11. V-3 and V-4 are 7199 tubes; one of each is installed on each PC-10 in the socket closest to the PC-11 board. V-5, V-6, V-7 and V-8 are 6BQ5/EL-84/7189 tubes, and they go in the remaining PC-10 sockets. Insert the pilot lamp in its socket.

The four rubber feet should be installed in the corner holes of the bottom plate. To mount each foot, insert a #6 machine screw in the recessed end of the foot, and secure it with a #6 nut on the inside of the bottom plate.

The bottom plate and the cover are attached at the same time, by setting the amplifier chassis on the bottom plate, which fits outside the main chassis, and then lowering the cover onto the chassis. The chassis, bottom plate and cover are fastened together by four sheet metal screws through the sides of the cover. This should be done *before* the front panel is installed.

Install the pilot light jewel by inserting it from the front of the panel, gripping the jewel spring with pliers to squeeze it open, and sliding the spring over the jewel to hold it in place. The panel should then be placed over the control shafts, and $\frac{3}{8}$ " nuts placed on the control shaft bushings to hold the panel in place. Use care in attaching the nuts to avoid scratching the finish of the panel. The cover can afterward be removed, if necessary, without removing the front panel.

All the knobs of the SCA-35 use small set screws to secure them to the shafts. A small tip screwdriver is required. The two large knobs go on the selector switch shaft and the volume control shaft. The selector switch shaft has a flattened portion, and the set screw in the knob should be tightened against the flat. Then when the knob is rotated fully counter-clockwise, the index mark on the knob should point to "Tape head".

The balance control and volume control knobs should be set so that the full counter-clockwise point corresponds to 7 o'clock on a clock face, and then full clockwise rotation will correspond to 5 o'clock. This makes the index on the balance control point to 12 o'clock for nominally balanced operation. However, either of these knobs can be installed offset if desired so that the 12 o'clock position represents average volume and balance in your individual system.

The *bass* control knob should be set so that full *counter-clockwise* is at 6 o'clock, and the *treble* control knob set so that full *clockwise* is at 6 o'clock. The 12 o'clock position will then be the electrically "flat" setting for each.

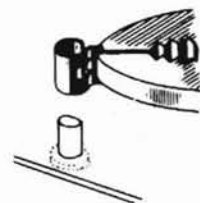

SPECIAL INSTRUCTIONS FOR OPTIONAL 120-240 VOLT POWER TRANSFORMERS

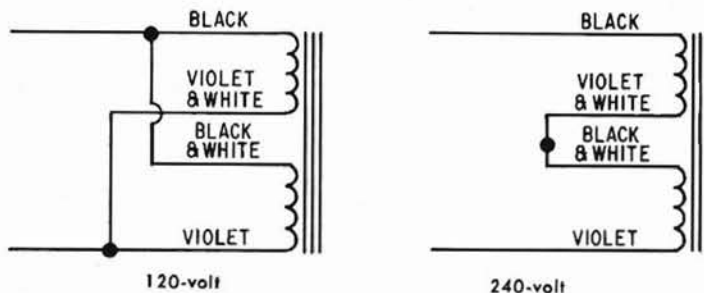

Dynakit SCA-35 amplifiers supplied with optional power transformer PB-028 can be wired for use with either 120 or 240 volt, 50 or 60 cycle, AC power sources, as follows:

For 120 Volt Operation

- 1 () Connect the black lead from the power transformer to lug #1 of AC outlet B.
- 2 () Connect the black-and-white lead from the power transformer to lug #1 of AC outlet B (S-3).
- 3 () Connect the violet lead to lug A on the fuse holder.
- 4 () Connect the violet-and-white lead to lug A on the fuse holder (S-2).

For 240 Volt Operation

- 1 () Connect the violet-and-white lead to lug #1 of terminal strip TS-1.
- 2 () Connect the black-and-white lead to lug #1 of terminal strip TS-1 (S-2).
- 3 () Connect the black lead to lug #1 of AC outlet B (S-2).
- 4 () Connect the violet lead to lug A on the fuse holder (S).

When using the 240 volt connection, a one ampere slo-blo fuse should be used instead of the two ampere fuse recommended for the 120 volt connection.

IN CASE OF TROUBLE

Although your SCA-35 should function properly after assembly, sometimes an error of wiring or a defective component may require trouble shooting. The location of a difficulty can be determined most efficiently if a systematic approach is used. This is based on understanding the inter-relationship between the different sections of the circuit, and reference to the section which describes the circuit will be helpful in achieving this understanding. The suggestions for servicing which follow are based on trying to localize the circuit section which is at fault.

Naturally, you should check and double check your wiring as a first step in trouble shooting. It is good to have somebody else check it through for you, as he may see an error which you overlook consistently. This checking can be done with the pictorial diagrams or with the step-by-step instructions. If you use both, you will have a double check on the accuracy of wiring. Look not only to see if all wires and components go to the correct points, but also to see that all solder connections are good and that no wires or parts touch spots where they should not. Sometimes a bit of solder will run from one point to another where no connection is desired. Sometimes a lead is left too long and hangs out, touching another point. All connections should be examined with this in mind.

Another source of trouble is that wires are twisted so tightly together that they break through the insulation and cause short circuits—or the wire itself may be broken within the insulation if twisted too tightly.

One general test should be made before serious trouble shooting begins. This is to determine whether the fault is in the SCA-35 or in associated equipment. Sometimes, connections to the loudspeakers are at fault, or it may be that the pickup cartridge is not connected properly in the player.

Pilot Light and/or Tubes Do Not Light

If after plugging the SCA-35 into an AC outlet and turning the power switch on, the pilot light does not go on, see whether there is a normal glow in the center of the tubes. If the tubes glow while the pilot light does not light, then the fault is in the pilot light itself—and the bulb should be replaced—or in the wiring to the pilot light socket. This wiring should be traced to see whether the connections are correct and soldering makes good contact. If some of the tubes light, but others do not, then the heater wiring to the unlighted tubes should be traced. There are two sets of heater wires, a set for each channel, one of which is brown and brown-white, the other green and green-white. These should be traced from the PA-774 transformer to TS-2 to see if the wiring compares with the pictorial diagram.

If *all* the tubes in one channel light, but none in the other channel, interchange the brown with green wires and brown-white with green-white temporarily to determine whether one of these sets of windings is defective. For example, if the interchange should make tubes light which were formerly not lighted, then there is nothing wrong with the wiring to the tubes, but most probably there is something wrong with the wiring from the transformer (which should be returned to DYNA Company for replacement in this case). This principle of substitution is helpful for locating the source of trouble.

If neither tubes nor pilot lamp light, then the first thing to check is the fuse. If this is blown, another of the same rating should be used, 2 ampere (except 1 ampere for 240 volt models). If the second fuse blows, then it is essential to determine the reason for this instead of continuing to replace fuses. *Under no circumstances should a fuse of higher rating be used.*

Blown Fuses

The fuse will blow if there is a short circuit in the equipment. If an ohmmeter is available, resistance measurements should be made at the two and four-section electrolytic capacitor terminals. Unplug the power cord and discharge each section of the capacitor to ground before making any of these measurements. The resistance to ground should be over 50,000 ohms on all sections except the blank terminal of the four-section capacitor where it should be about 95 ohms. Any lesser resistance values indicate either capacitor failure or a path to chassis which should not exist. Disconnect wires to each capacitor section to isolate the capacitor. All sections should read high resistance once wires are disconnected—if not, the capacitor is at fault.

If one of the silicon diodes is defective, or if it has been installed backwards, the four-section capacitor will probably have been permanently damaged. In similar fashion, if the four-section capacitor is defective, it may cause the failure of the silicon diodes. Therefore, if either capacitor or diodes are found to be at fault, both should be replaced.

Blown fuses can also indicate a defective PA-774 transformer (though this is a rare possibility). To check for this, disconnect all leads of the PA-774 except the two black primary leads; and with these leads in position where they touch neither each other nor other components, plug in the unit and turn it on. If the fuse blows under this condition, the trouble is definitely in the PA-774. If the PA-774 is proven satisfactory in this test, test the diodes and capacitors by disconnecting all wires to the capacitors except the wire from lug #2 on TS-1 to lug #3 of the four-section filter capacitor, leaving the resistors on the capacitor terminals. If plugging in the unit and turning it on then does not blow a fuse, these components are exonerated, and it is necessary to seek a short circuit elsewhere in the circuit.

The output tubes can be tested as the source of blown fuses by removing *all* the 6BQ5's *simultaneously* from their sockets. If this cures fuse blowing, then one of them is probably bad. The unit should never be operated with only one, two or three of these four tubes inserted or damage to the remaining tubes is probable. Heater glow at the top and bottom of each tube is normal, but if the plate (the large black metal part) of the output tubes glows red it indicates a probable short in the tube or at pin #3 of any of the output tube sockets, or a short to the chassis of some part of the heater wiring.

Both Channels Not Working

Should neither channel function, there is the possibility that a similar mistake has been made in the wiring to both sides. This is an unlikely situation, but it should be checked by visual comparison of the wiring with the diagrams.

Generally, the cause of malfunction of both channels together lies in the one section of the unit which is common to both channels — the power supply. The checking of this section is covered earlier.

It is also possible that the unit is working on radio or other high level input, but not on phono or tapehead. If this is true for both channels together, then the power supply wiring which connects to the PC-11 board should be checked, as this is the only element common to both channels in the preamplifier section.

One Channel Not Working

If tubes in one channel do not light, the heater circuits must be checked as described above. Tubes can be interchanged between the two sides to see if substitution shows up a faulty tube. If this cures the bad channel, then evidently the faulty tube has been located.

If it is not a tube which causes the trouble, then it is necessary to determine whether it is in the preamp section (the PC-11) or the amplifier section (the PC-10). If radio input is satisfactory while phono is not, then the trouble is in the PC-11 section which handles phono and tapehead inputs, or in the wiring associated with the selector switch.

If no inputs function, then the difficulty is either in the front panel wiring which includes the tone control sections, or in the PC-10 section or in the Z-565 output transformer which connects to that channel. The wiring of the front panel must be carefully compared on both left and right channels. It is possible to re-do the wiring and to interchange the two PC-10 boards to determine whether the fault is on one of these. It is also possible to interchange the Z-565 output transformers to try to isolate the trouble. However, a fault in the output transformer is most unlikely, and this should be tried as a last resort.

If both channels work on radio or other high level input, but only one works on phono or tapehead input, then the trouble is in either the PC-11 board or in the selector switch or in the front panel wiring from selector switch through the front panel controls. The PC-11 board has both preamplifier sections in a parallel arrangement, so comparison visually of wiring and parts should indicate whether there is any difference between these sections.

Each section of the selector switch should be identical in appearance and in wiring. These should be compared carefully. The 12AX7's on the PC-11 should be interchanged to see if one is at fault.

Hum and Noise

If the unit is working, but there is excessive hum or noise, the first step is to see whether the trouble is in the SCA-35 or associated equipment. The SCA-35 should be checked alone, with all other equipment except the speakers disconnected, and with the cover and bottom plate on the SCA secured in place. If the hum is reduced without the other equipment, then it will be necessary to determine what kind of ground connections are necessary between equipment to reduce the hum. Sometimes connecting wires from chassis to chassis are good, sometimes they are harmful. Reversing line plugs on associated equipment may be helpful. It must be understood that hum which disappears when associated equipment is disconnected or turned off, is not a problem of the SCA-35.

Hum which persists after other equipment is eliminated as a source of trouble is generally a result of either faulty wiring or a faulty tube. Wires which are not positioned as shown in the diagrams, may be a cause of hum. This is particularly true for the wires which lead from the PA-77 transformer, since these wires carry AC currents which may be a source of hum.

If a tube causes the problem, then it is not likely to appear in both channels simultaneously. If the hum is loud with the volume control turned down, then it is most likely to be associated with the 7199 tube. If it occurs on phono or tapehead inputs with the volume turned up a bit, then it is most likely to be associated with the 12AX7 tube for the channel which shows the hum. These tubes can be checked by substituting in the other channel.

An objectionable level of hiss is most likely caused by a defective resistor on a printed circuit board. If it is heard with the volume turned down, it is likely to be part of the 7199 circuit — it can often be located by wiggling the body of the resistor (using insulated pliers) to see if the hiss is affected. If it is on phono or tapehead input, with volume turned up, then the same possibility applies to the 12AX7 circuit.

Some hum and hiss will always exist — depending on speaker efficiency and other factors. However, it should be negligible at normal listening levels. At very high levels, some noise will always be audible, but of course this will be masked by the loud sound. With the volume control at minimum, noise with a shorted input should be less than 2 millivolts across the 16 ohm output; with volume at maximum, it should not exceed 40 millivolts at this point.

Sometimes, the magnetic field around the PA-774 transformer may cause some vibration of the cover which is audible as a buzzing sound. This can be eliminated by placing a small wedge of fibreboard or wood on top of the transformer, between it and the cover.

Distortion

If distortion is encountered, the first thing to do is to make sure that all inputs and outputs are properly connected and properly functioning. If the leads to a loudspeaker have frayed cables and touch several screws simultaneously, this can be a source of distortion. If a ceramic cartridge is inserted into the magnetic cartridge input (or if a tape amp goes in the tapehead input) there will be overloading of the input and severe distortion.

If the trouble seems to be in the SCA-35, then determine if it is in one channel or both. If in both channels, the only circuitry common to both channels is that of the power supply and the 95 ohm resistor in the cathode circuits of the 6BQ5 tubes.

If only one channel has distortion, tests similar to those described previously should be used to localize the problem and tubes should be interchanged to see if they are a cause of it. Inspection of parts on the printed circuit boards should be made to see if both sides of the circuit are identical.

Voltage Measurements

The voltage chart shown with the schematic diagram will be of considerable aid in troubleshooting if there is a vacuum tube voltmeter or similar test instrument available. Voltages through the circuit should be compared carefully with this chart. Deviations up to 20% are not signs of abnormality, but past this range they indicate a malfunctioning of the circuit at that point. Such measurements can help to locate defective parts, miswiring, or bad tubes.

All resistors are 1/2 watt, 10% unless otherwise noted.

- R 1 1.2 megohms
- R 2 150,000 ohms 1 watt 5%
- R 3 5,600 ohms 5%
- R 4 120 ohms 1 watt 5%
- R 5 120 ohms 1 watt 5%
- R 6 1.2 megohms
- R 7 47,000 ohms
- R 8 390 ohms
- R 9 18,000 ohms 5%
- R 10 100,000 ohms 5%
- R 11 47,000 ohms
- R 12 1.5 megohms
- R 13 1.2 megohms
- R 14 150,000 ohms 1 watt 5%
- R 15 5,600 ohms 5%
- R 16 120 ohms 1 watt 5%
- R 17 120 ohms 1 watt 5%

- R 18 1.2 megohms
- R 19 47,000 ohms
- R 20 390 ohms
- R 21 18,000 ohms 5%
- R 22 100,000 ohms 5%
- R 23 47,000 ohms
- R 24 1.5 megohms
- R 25 10,000 ohms
- R 26 10,000 ohms
- R 27 18,000 ohms
- R 28 18,000 ohms
- R 29 4.7 megohms
- R 30 270,000 ohms 1 watt 5%
- R 31 560 ohms 5%
- R 32 22,000 ohms 1 watt 5%
- R 33 120,000 ohms 5%
- R 34 27,000 ohms 1 watt 5%

- R 35 470,000 ohms
- R 36 470,000 ohms
- R 37 82,000 ohms 5%
- R 38 22,000 ohms
- R 39 2200 ohms 1 watt
- R 40 2200 ohms 1 watt
- R 41 50 ohms 5 watts
- R 42 95 ohms 5 watts 5%
- C 1 .1 mfd @ 16 v.
- C 2 22 nf @ 400 v.
- C 3 .1 mfd @ 400 v.
- C 4 330 pf mica 5%
- C 5 3.3 nf 10%
- C 6 .1 mfd @ 16 v.
- C 7 22 nf @ 400 v.
- C 8 .1 mfd @ 400 v.

- C 9 330 pf mica 5%
- C 10 3.3 nf 10%
- C 11 10 nf 10%
- C 12 10 nf 10%
- C 13 3.3 nf 10%
- C 14 3.3 nf 10%
- C 15 22 nf 10%
- C 16 22 nf 10%
- C 17 .1 mfd @ 16 v.
- C 18 1 mfd @ 250 v.
- C 19 .1 mfd @ 400 v.
- C 20 .1 mfd @ 400 v.
- C 21 12 pf @ 600 v. 5%
- C 22 .02 mfd @ 500 v.
- C 23 50/50 mfd @ 450 v.
- C 24 60/40/20 @ 450 v.; 100 @ 25 v.

- D 1
- D 2
- volume
- balance
- bass co
- treble c
- hum co
- V 1
- V 2
- V 3
- V 4
- V 5
- V 6
- V 7
- V 8

PC-II

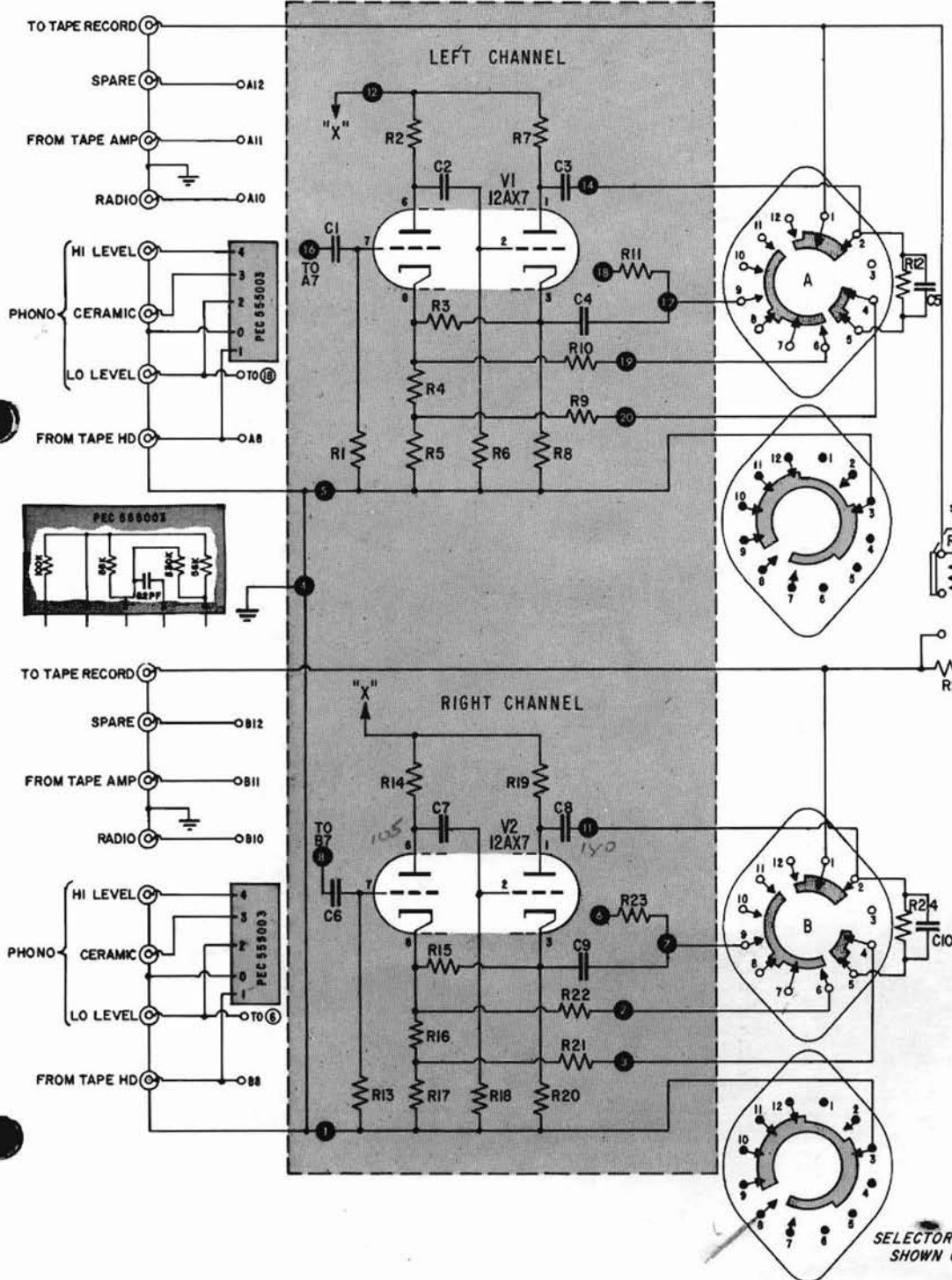

VOLTAGE CHART

PIN	1	2	3	4	5
V1 & V2 (12AX7)	180	-2	.5	6.3 A.C.	
V3 & V4 (7199)	255	55	32	6.3 A.C.	
V-5-6-7-8 (6BQ5)	0*	0	16	6.3 A.C.	
TS-1 LUG	0	380	0	315	315
C24 LUG	380	370	350	14	
C23 LUG	320	250			

* UNUSED PINS MAY HAVE INTERNAL CONNECTIONS. SOME TUBES (DEPENDING ON BRAND), MAY VARY AT THESE POINTS.
VOLTAGES MEASURED WITH V.T.V.M.

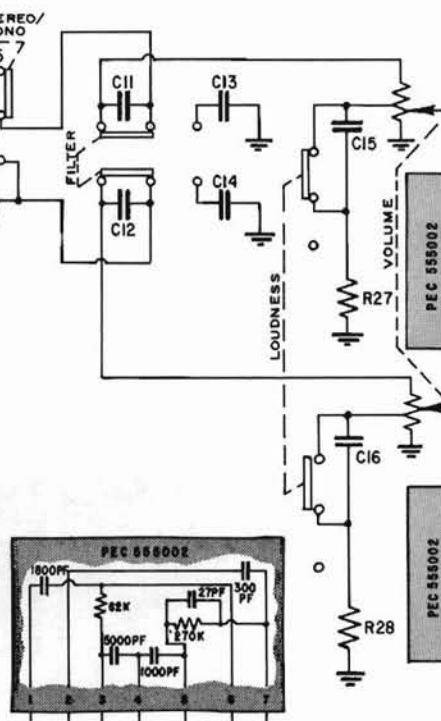

SELECTOR SWITCH SHOWN CCW

SCHEMATIC DIAGRAM

- 1 Silicon rectifier, 500 ma, 1000 PIV
- 2 Silicon rectifier, 500 ma, 1000 PIV
- 3 volume control—250,000 ohms
- 4 balance control—750,000 ohms
- 5 bass control—2 megohms
- 6 treble control—500,000 ohms
- 7 sum control—1,000 ohms
- 8
- 9
- 10
- 11
- 12
- 13
- 14
- 15
- 16
- 17
- 18

TABLE

	5	6	7	8	9
5.3 A/c		105	0	.25	
5.3 A/c		.7	0	70	55
5.3 A/c		0*	360	0*	365
	315				

ALL CONNECTIONS, THEREFORE (IF NOT SHOWN), MAY HAVE VOLTAGES APPLICABLE TO THE POWER SUPPLY.

V.M.

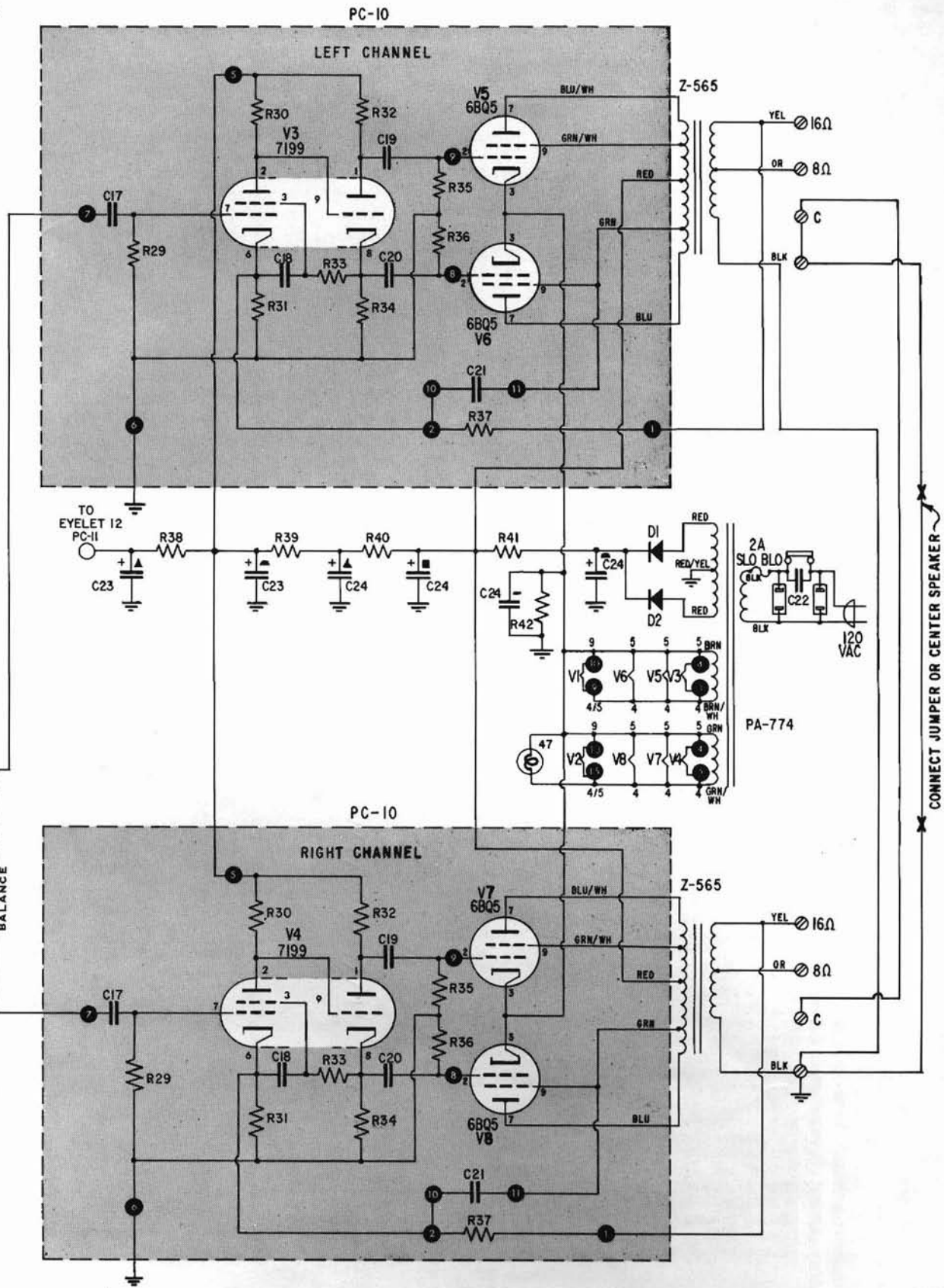
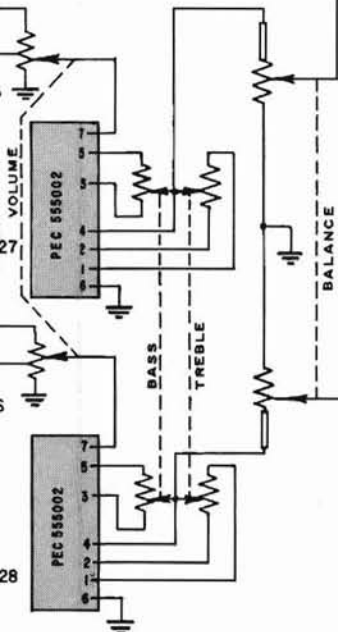

CONNECT JUMPER OR CENTER SPEAKER

FACTORY SERVICE AND WARRANTY

The SCA-35 is designed to provide reliable, trouble-free performance for a long period of time, when properly assembled and installed. It is intended for use with the 120-volt AC power supplied to most homes. Although variations of several volts above or below this figure will have no pronounced effect upon performance or component life, the normal guarantee on the equipment is not applicable if it is operated with AC inputs greater than 130 volts. If your local power is this high or higher in voltage, it is suggested that a voltage regulating or adjusting device be installed to protect the amplifier.

All parts used in the SCA-35 are guaranteed for a period of one year from the date of purchase except tubes, which carry the standard electronic industry (EIA) 90-day warranty. Defective parts will be replaced at no charge if they are returned prepaid to the factory either directly or via the dealer from whom the kit was purchased. After the guarantee period has passed, DYNACO, Inc. will supply any non-standard parts used at net prices. Parts which are standard (resistors, capacitors, tubes) can generally be purchased from a local electronics supply store.

If it is believed that a transformer is defective, it should be disconnected by unsoldering, never by cutting its leads so short that it cannot be re-used. *Warranties on the transformers are void if the leads are cut too short for re-use.*

If the kit has been completely assembled, yet cannot be made to function properly, or if difficulty is apparent after a short period of use, we will service the kit for a fixed charge of \$10.00, plus the cost of the parts which are outside the warranty or have been damaged by the user.

Factory assembled amplifiers include a one-year warranty on labor as well as parts.

Fixed-charge service and maintenance are not available for kits which are incompletely wired or kits wired with solder other than rosin core type, or kits physically or electrically modified without prior factory authorization. The serial number on the front cover of this instruction book must be mentioned in all correspondence and in any case where parts are returned, or kits sent or brought to the factory for service.

It is the factory prerogative to limit the service facility to one year from the date of purchase.

When shipping the amplifier to DYNACO, Inc., for service, attach a note specifying the symptoms, the name and address of the sender, and the serial number of the kit. The kit should be securely packed to withstand the abuses of handling in transit. The front plate should be protected with a plastic or wax paper covering, or it may be removed. The unit should be placed in a rugged carton surrounded by several inches of shredded paper or other soft packing material. The original carton in which the amplifier is supplied is suitable for shipping if the original inserts are properly used.

Shipment should be made by prepaid EXPRESS, where possible; repaired kits will then be returned EXPRESS C.O.D. for freight and service charges (unless these charges have been prepaid). PARCEL POST IS NOT A SAFE METHOD FOR THE SHIPMENT OF ASSEMBLED KITS, AND SHOULD NOT BE USED FOR THIS PURPOSE.

The DYNA Company assumes no liability or responsibility for damages or injuries sustained in assembly or operation of the Dynakit.

PARTS LIST

Parts of similar type which do not change performance may sometimes be included as a matter of expediency. This will account for slight variations in value or appearance.

Resistors

- ✓ 50 ohms, 5 watts, 10% — R41
- ✓ 95 ohms, 5 watts, 5% — R42
- ⊘ 2200 ohms (red-red-red), 1 watt, 20% — R39, R40
- ⊘ 10,000 ohms (brown-black-orange), 1/2 W, 10% — R25, R26
- ⊘ 18,000 ohms (brown-gray-orange), 1/2 W, 10% — R27, R28
- ⊘ 22,000 ohms (red-red-orange), 1/2 W, 10% — R38
- ⊘ 1.5 megohms (brown-green-green), 1/2 W, 10% — R12, R24

Capacitors

- ⊘ 22 nf (.02 mfd) 10% — C15, C16
- ✓ 10 nf (.01 mfd) 10% — C11, C12
- ✓ 3.3 nf (.0033 mfd) 10% — C5, C10, C13, C14
- ✓ .02 mfd 500V disc — C22
- ✓ Two-section filter capacitor, 50/50 @ 450V — C23
- ✓ Four-section filter capacitor, 60/40/20 @ 450V; 100 @ 25V — C24

Hardware

- 57 #4 Machine screws
- 49 #4 Nuts
- 49 #4 Lockwashers
- 4 #6 Machine screws
- 4 #6 Nuts
- 18 #6 Sheet metal screws
- 12 #8 Machine screws
- 12 #8 Nuts
- 12 #8 Lockwashers
- 10 3/8" Control mounting nuts
- 5 3/8" Lockwashers
- ✓ Ground lug
- ✓ Pilot light jewel
- ✓ Pilot light jewel spring
- ✓ Rubber grommet
- ✓ Cable clamp
- ✓ Rubber feet

Controls

- ✓ Selector switch — 134601
- ✓ Volume control — 177254
- ✓ Balance control — 167754
- ✓ Bass control — 167205
- ✓ Treble control — 167504
- ✓ Hum control — 147102
- ✓ DPDT slide switch (six lugs)
- ✓ SPST slide switch (two lugs)
- ✓ Fuse holder with rubber washer and circular nut
- ✓ Fuse, 2 ampere, Slo-Blo
- ✓ PEC tone control circuit module (7 leads) — 555002
- ✓ PEC input circuit module (5 leads) — 555003
- ✓ Silicon rectifier, 500 ma 1000 PIV
- ✓ Mounting wafers for filter capacitors
- ✓ Pilot light socket
- ✓ Pilot lamp #47
- ✓ AC outlet
- ✓ 4 socket input socket strip
- ✓ 4 screw terminal strip
- ✓ 5 lug terminal strip
- ✓ 9 pin tube socket
- ✓ Hookup wire (1 each red, green, black)
- ✓ Flat 4-conductor cable
- ✓ Insulating sleeving (black)
- ✓ Line cord with plug
- ✓ Chassis assembly (5 pieces)
- ✓ PA-774 power transformer
- ✓ Z-565 output transformer
- ✓ PC-10 circuit board assembly
- ✓ PC-11 circuit board assembly
- ✓ Output tube 6BQ5/EL-84/7189 (matched)
- ✓ Driver tube 7199
- ✓ Preampifier tube 12AX7/ECC-83
- ✓ Large knob
- ✓ Small knob
- ✓ Front panel
- ✓ Instruction manual with pictorial diagrams
- ✓ Warranty card

